

# **molbox2™/molbox2-S™** molbloc® Terminal

## Operation and Maintenance Manual

## **LIMITED WARRANTY AND LIMITATION OF LIABILITY**

Each Fluke product is warranted to be free from defects in material and workmanship under normal use and service. The warranty period is 1 year and begins on the date of shipment. Parts, product repairs, and services are warranted for 90 days. This warranty extends only to the original buyer or end-user customer of a Fluke authorized reseller, and does not apply to fuses, disposable batteries, or to any product which, in Fluke's opinion, has been misused, altered, neglected, contaminated, or damaged by accident or abnormal conditions of operation or handling. Fluke warrants that software will operate substantially in accordance with its functional specifications for 90 days and that it has been properly recorded on non-defective media. Fluke does not warrant that software will be error free or operate without interruption.

Fluke authorized resellers shall extend this warranty on new and unused products to end-user customers only but have no authority to extend a greater or different warranty on behalf of Fluke. Warranty support is available only if product is purchased through a Fluke authorized sales outlet or Buyer has paid the applicable international price. Fluke reserves the right to invoice Buyer for importation costs of repair/replacement parts when product purchased in one country is submitted for repair in another country.

Fluke's warranty obligation is limited, at Fluke's option, to refund of the purchase price, free of charge repair, or replacement of a defective product which is returned to a Fluke authorized service center within the warranty period.

To obtain warranty service, contact your nearest Fluke authorized service center to obtain return authorization information, then send the product to that service center, with a description of the difficulty, postage and insurance prepaid (FOB Destination). Fluke assumes no risk for damage in transit. Following warranty repair, the product will be returned to Buyer, transportation prepaid (FOB Destination). If Fluke determines that failure was caused by neglect, misuse, contamination, alteration, accident, or abnormal condition of operation or handling, including overvoltage failures caused by use outside the product's specified rating, or normal wear and tear of mechanical components, Fluke will provide an estimate of repair costs and obtain authorization before commencing the work. Following repair, the product will be returned to the Buyer transportation prepaid and the Buyer will be billed for the repair and return transportation charges (FOB Shipping Point).

**THIS WARRANTY IS BUYER'S SOLE AND EXCLUSIVE REMEDY AND IS IN LIEU OF ALL OTHER WARRANTIES, EXPRESS OR IMPLIED, INCLUDING BUT NOT LIMITED TO ANY IMPLIED WARRANTY OF MERCHANTABILITY OR FITNESS FOR A PARTICULAR PURPOSE. FLUKE SHALL NOT BE LIABLE FOR ANY SPECIAL, INDIRECT, INCIDENTAL OR CONSEQUENTIAL DAMAGES OR LOSSES, INCLUDING LOSS OF DATA, ARISING FROM ANY CAUSE OR THEORY.**

Since some countries or states do not allow limitation of the term of an implied warranty, or exclusion or limitation of incidental or consequential damages, the limitations and exclusions of this warranty may not apply to every buyer. If any provision of this Warranty is held invalid or unenforceable by a court or other decision-maker of competent jurisdiction, such holding will not affect the validity or enforceability of any other provision.

Fluke Corporation  
6920 Seaway Blvd  
Everett, WA 98203  
U.S.A.

11/99

# Table of Contents

Title	Page
Introduction.....	1
Contact Fluke .....	1
Safety Information .....	1
Product Overview .....	1
molbloc Flow Elements.....	3
molbloc-L Flow Element.....	3
molbloc-S Flow Element.....	4
Specifications .....	5
General Specifications.....	5
Reference Pressure Transducer (RPT) Specifications .....	6
Temperature Measurement Specifications.....	6
MFC Control Function (Optional) Specifications.....	6
Flow Measurement Specifications.....	7
molbloc-L .....	7
molbloc-S.....	13
Front Panel .....	19
Rear Panel.....	20
Installation .....	21
Unpack and Inspect the Product.....	21
Remove from Package .....	21
Inspect the Contents .....	21
Site Requirements .....	23
Initial Setup .....	23
Prepare for Operation.....	23
Power Connection .....	24
molbox2 to molbloc Connections.....	24
Gas Supply and Flowpath Connections.....	24
Vacuum Supply (molbloc-S only) .....	26
Communications Connections .....	26
MFC Control Option Connection.....	27
Power Up and Verification .....	27
Power Up .....	27
Check Proper Pressure Measurement Operation .....	27
Check Proper Temperature Measurement Operation.....	28
Check the MFC Control Function (Optional) .....	28

Leak Check .....	28
Check/Set Security Level .....	28
Additional Precautions to Take Before Making Flow Measurements .....	28
Short Term Storage .....	29
Operation .....	29
General Operating Principles .....	29
molbloc Channel A and Channel B .....	29
molbloc-L and molbloc-S Operation .....	30
Flow Ready/Not Ready Indication .....	31
Reference Pressure Transducer (RPT) Overpressure .....	32
molbloc-S BPR Limits .....	32
Main Run Screen .....	34
molbloc-L Operation .....	34
molbloc-S Operation .....	36
Manual Operation .....	38
Direct Function Keys Summary .....	39
Direct Function Keys .....	40
[K] .....	40
[GAS] .....	42
[UNIT] .....	48
[TARE] .....	55
[P&T] (Pressure and Temperature) .....	81
[DISPLAY] .....	84
[A/B] .....	96
[MFC] (Optional) .....	97
[RES] .....	100
[Setup] .....	101
<1molbloc> .....	102
<2stab> .....	104
<3ADJ> .....	105
<4A_B> .....	106
<5MFC> .....	110
<6REG> .....	111
<7FLOWU> .....	113
<8PRESU> .....	113
<9TEMPU> .....	114
[SPECIAL] .....	114
<1reset> .....	115
<2level> .....	118
<3UL> .....	122
<4cal> .....	124
<5Prefs> .....	124
<6REMOTE> .....	126
<7Drivers> .....	128
<8Head> .....	129
<9BPR> .....	131
Remote Operation .....	134
Overview .....	134
Interfacing .....	134
RS232 Interface .....	135

IEEE-488 (GPIB) .....	137
Commands .....	137
Command Syntax.....	137
Command Summary .....	138
Error Messages .....	141
Command Descriptions.....	142
Status System .....	184
Status Reporting System .....	184
Maintenance, Adjustments, and Calibration.....	187
Product Overview .....	187
Clean the Product.....	188
Product Disposal.....	188
Calibration Of Reference Pressure Transducers (RPTS) .....	188
Required Equipment.....	190
Set-Up and Preparation .....	190
View and Edit RPT Readings and Calibration Information .....	191
RPT Calibration/Adjustment Procedure Without Using CalTool for RPTs Software .....	194
MFC Control Function Adjustment.....	195
OHMIC Measurement [Temperature] System Verification .....	197
OHMIC Measurement System Calibration/Adjustment Procedure .....	199
molbloc Flow Adjustment .....	200
molbloc Adjustment Procedure Without Using CalTool for molbloc Software .....	201
Reloading Embedded Software Into molbox2 Flash Memory.....	202
Reload molbloc EEPROM File .....	202
OVERHAUL .....	203
Troubleshooting.....	203
Appendix .....	215
Conversion of Numerical Values .....	215
Pressure.....	215
Temperature .....	216
Flow.....	216
Valve Drivers.....	219
MFC Control Function-MFC Connector .....	221
Glossary.....	225



## Introduction

The Fluke Calibration molbox2™/molbox2-S™ molbloc® Terminal (the Product) are support units for making gas flow measurements using molbloc mass flow elements. This manual details Product Operation and Maintenance.

## Contact Fluke

Fluke Corporation operates worldwide. For local contact information, go to our website: [www.flukecal.com](http://www.flukecal.com).

To register your product, or to view, print, or download the latest manual or manual supplement, go to our website.

+1-425-446-5500 [info@flukecal.com](mailto:info@flukecal.com)

## Safety Information

General Safety Information is in the printed Safety Information document that ships with the Product and at [www.fluke.com](http://www.fluke.com). More specific safety information is listed where applicable.

A **Warning** identifies hazardous conditions and procedures that are dangerous to the user. A **Caution** identifies conditions and procedures that can cause damage to the Product or the equipment under test.

## Product Overview

### Note

*Throughout this manual, references to NIST or NIST RefProp does not imply recommendation or endorsement by NIST.*

molbox2-S is for higher flows and only supports molbloc-S mass flow elements. A molbox2 supports both molbloc-L and molbloc-S. Each product reads calibration data from a molbloc EEPROM and measures molbloc upstream and downstream pressure with built-in high precision Reference Pressure Transducers (RPTs). The Product supports these RPT ranges: molbox2 A350K, molbox2 A700K, molbox2-S A1.4M and molbox2-S A2M.

An ohmic measurement system reads the resistance of the molbloc platinum resistance thermometers from which the molbloc temperature is calculated. The flow rate of the gas that flows through the molbloc is calculated with the molbloc calibration data, measured pressures, and temperature and gas properties stored in memory.

Internal molbox2 valves support on-board PRESSURE TRANSDUCER TARING, molbloc-S BPR MODES, LEAK TESTING, and SELF PROTECTION functions as well as a GAS PURGE routine. The molbox2-S does not support PRESSURE TRANSDUCER TARING as it does not support molbloc-L operation and does not include a bypass valve to connect the upstream and downstream RPTs.

molbox2 provides a local user interface with a front-panel key pad and display, and includes advanced on-board functions. RS232 and IEEE 488 interfaces support remote communication capability.

molbox2 handles molblocs on two separate channels. This allows easy switching between two different molblocs as well as certain special dual channel functions. Internal valving switches the molbox2 pressure transducers from one molbloc to the other as needed.

molbox2 is for applications in which minimizing measurement uncertainty is the most important requirement and/or integrated control of mass flow controllers (MFCs) is needed.

molbox2 includes:

- Backwards compatibility with most previous molblocs.
- Flow calculation response ~3 times faster than previous versions.
- Support or upgrade for molbloc-L to use an enhanced laminar flow calculation published by NIST. This provides the ability to flow any gas selectable in the molbox2 with a molbloc-L within a stated uncertainty specification based upon available gas property uncertainties using just an accredited N2 calibration.
- Flow uncertainty specification available using a remote command only for molbloc-L that support the enhanced NIST calculation.
- Support of 27 total gases (7 added gases: Propylene, Acetylene, Neon, Krypton, isoButane, Deuterium, Natural Gas).
- Availability to add gas properties to the molbox2 for gases or gas mixtures not currently loaded.
- Availability to update existing gas properties if newer data becomes available.
- Support for Q-RPT pressure sensor technology to improve linearity and precision on pressure measurements.
- Improved gas property uncertainty that uses data from NIST Reference Fluid Thermodynamic and Transport Properties Database 10 (REFPROP 10), and flow calculation improvements from a NIST paper published in 2012.
- Support of expanded molbloc modelization and polynomial linearization data structure and calculations. This new molbloc data structure allows greatly improved flow measurement performance across the supported operating pressure and flow/Reynolds number ranges. This new model makes the Premium calibration option and resulting specifications possible.

- Support for *named* molbloc calibrations - this allows storage of multiple pressure-dependent calibrations in each gas on a molbloc. This also provides for stated operating limits of pressure, flow, and Reynolds number to be stored on the molbloc so the molbox2 can alert the user of operating conditions that are outside of the calibrated parameters, to avoid out of tolerance measurements.
- Simplified internal pneumatic design.

molbox2 terminals are produced with serial numbers of 4000 and higher. Older molbox or molbox1+ terminals may be eligible for upgrade to molbox2 hardware, software and specifications by Fluke Calibration.

## molbloc Flow Elements

The Product supports these molblobs:

- molbloc-L (laminar) molbox2 only
- molbloc-S (sonic)

The Product supports molblobs with updated data structures (Product version above 7.00) and previous data structures. The flow calculation based on the NIST paper is only available on molbloc-L with Product version 7.00 and above. Premium calibrations and specifications are only available with molblobs at Product version 6.00 and higher with an actual gas calibration.

## molbloc-L Flow Element

molbloc-L is the original molbloc laminar flow element. molbloc-L covers the lower portion of the molbloc/molbox2 system flow range. The key molbloc-L measurement is the differential pressure across the element, which is roughly proportional to the mass flow rate through it. molbloc-L elements are calibrated for use at an absolute pressure which remains nearly constant, while the differential pressure varies with flow rate. Different operating pressure options and their effect on molbloc flow range are described under Standard molbloc-L Calibrations in the Product Specifications. See [Specifications](#).

All molbloc-L elements of range 1E1-L to 3E4-L produced or upgraded after the release of molbox2 come standard with an upstream ¼ in VCR flange, or flowpath connection, that has an integrated sintered metal filter. This filter is a last defense against particulate contamination of the molbloc-L internal flowpath which can affect molbloc-L measurements. Make every effort to supply clean, dry gas to the molbloc to ensure its measurement performance and long-term stability. molblobs that have the integrated upstream filter are recognizable by the visible filter element as shown in [Figure 1](#).

**Figure 1. molbloc-L Upstream End Flange with Integrated Filter**

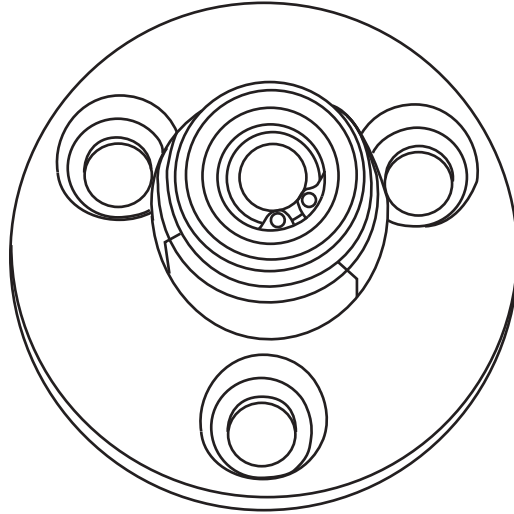

New molbloc-L elements produced with molbox2 calibration data structure, premium calibration options, and integrated filter hardware are identified by a serial number of 10000 or higher. Most older molbloc-L elements are eligible for upgrade.

## **molbloc-S Flow Element**

molbloc-S elements use critical (sonic) flow venturi nozzle technology to measure flows which overlap with the ranges of molbloc-L and cover the higher end of the Product system flow range. The mass flow rate through a molbloc-S element is roughly proportional to the upstream absolute pressure when the flow is *choked*, so the molbloc-S operating pressure can vary widely as the mass flow rate is changed throughout the flow range. The limits of molbloc-S operating pressure and flow ranges are defined by the molbloc-S calibration type, described in Premium molbloc-S Calibrations in the Product Specifications. See [Specifications](#).

The calibration data structure and premium calibration options for molbloc-S introduced with molbox1+ function the same on molbox2. molbloc-S elements produced with this support have serial number of 4000 or higher. Older molbloc-S elements are eligible for upgrade to version 6.00 format.

# Specifications

## General Specifications

### Note

Safety and other related specifications are printed in the Safety Information document that shipped with the Product and can be found at [www.fluke.com](http://www.fluke.com).

Vibration	Meets MIL-T-28800D
Weight	6.8 kg (15 lb) max.
Dimensions	32 cm W x 12 cm H x 30 cm D (12.6 in. x 4.7 in. x 11.8 in.) approx.
Communication Ports	RS232 (COM1), RS232 (COM2), IEEE-488
Reference Pressure Transducers(RPTs)	<p><b>molbox2 A350K</b> 2 x 300 kPa (44 psia) calibrated range oscillating quartz crystal</p> <p><b>molbox2 A700K</b> 2 x 600 kPa (87 psia) calibrated range oscillating quartz crystal</p> <p><b>molbox2-S A1.4M</b> 1 x 1200 kPa (174 psia) calibrated range oscillating quartz crystal, 1 x 300 psi silicon based</p> <p><b>molbox2-S A2M</b> 1 x 2000 kPa (290 psia) calibrated range oscillating quartz crystal, 1 x 300 psi silicon based</p>
Pressure Limits	<p><b>molbox2 A350K</b> Maximum working pressure 300 kPa absolute (44 psia) Maximum pressure without damage 350 kPa absolute (50 psia)</p> <p><b>molbox2 A700K</b> Maximum working pressure 600 kPa absolute (87 psia) Maximum pressure without damage 700 kPa absolute (102 psia)</p> <p><b>molbox2-S A1.4M</b> Maximum working pressure 1200kPa absolute (174 psia) Maximum pressure without damage 1500 kPa absolute (218 psia)</p> <p><b>molbox2-S A2M</b> Maximum working pressure 2000 kPa absolute (290 psia) Maximum pressure without damage 2200 kPa absolute (319 psia)</p>
Pressure Connections	Quick connectors equivalent to Swagelok® QM Series (M2-B200)
Ohmic Measurement System	<p>Resolution 0.004 Ω</p> <p>Accuracy ±0.04 Ω</p> <p>Accuracy of 100 Ω and 110 Ω reference resistors ±0.01 %</p> <p>Stability of 100 Ω and 110 Ω reference resistors ±0.005 % per 3 yrs</p>
Gases Supported	<p>molbloc-L and molbloc-S</p> <p>Nitrogen (N2), dry Air, humid Air (molbloc-S only), Argon (Ar), Butane (Butn), Carbon Monoxide (CO), Helium (He), Oxygen (O2), Carbon Dioxide (CO2), Carbon Tetrafluoride (CF4), Octofluorocyclobutane (C4F8), Ethane (C2H6), Ethylene (C2H4), Fluoroform (CHF3), Hexafluoroethane (C2F6), Hydrogen (H2), Methane (CH4), Nitrous Oxide (N2O), Propane (C3H8), Sulfur Hexafluoride (SF6), Xenon (Xe), Propylene (C3H6), Acetylene (C2H2), Neon (Ne), Krypton (Kr), isoButane (iBtn), Deuterium (D2), Natural Gas (NG).</p> <p>Availability to add custom gases and mixtures not currently on the molbox.</p>
Flow Ranges	See <a href="#">Flow Measurement Specifications</a>
Valve Driver Option	(8) 12 V outputs. Each output can sink,500 mA at 12 V, max. 1 A total (see <a href="#">Valve Drivers</a> )

## Reference Pressure Transducer (RPT) Specifications

Type	Oscillating quartz crystal with mechanical bellows	
Calibrated Range	<b>A350K</b> <b>A700K</b> <b>A1.4M</b> <b>A2M</b>	20 kPa to 300 kPa absolute (2.9 psia to 44 psia) 20 kPa to 600 kPa absolute (2.9 psia to 87 psia) 100 kPa to 1200 kPa absolute (14.5 psia to 174 psia) 100 kPa to 2000 kPa absolute (14.5 psia to 290 psia)
Resolution	<b>A350K</b> <b>A700K</b> <b>A1.4M</b> <b>A2M</b>	0.4 Pa (0.00005 psi) 0.7 Pa (0.0001 psi) 1.4 Pa (0.0002 psi) 2 Pa (0.0003 psi)
Accuracy	A350K Absolute pressure <sup>[1]</sup> Differential A700K Absolute pressure <sup>[1]</sup> Differential A1.4M Oscillating Quartz Up (HI) Absolute pressure <sup>[1]</sup> Silicon based Down (LO) Absolute pressure A2M Oscillating Quartz Up (HI) Absolute pressure <sup>[1]</sup> Silicon based Down (LO) Absolute pressure	±(0.01 % of reading or 0.003 % Q-RPT span, whichever is greater) ±(4.2 Pa (0.0006 psi) or 0.026 % ΔP, whichever is greater) ±(0.01 % of reading or 0.003 % Q-RPT span, whichever is greater) ±(8.4 Pa (0.0012 psi) or 0.032 % ΔP, whichever is greater) ±(0.01 % of reading or 0.003 % Q-RPT span, whichever is greater) ±0.06 % of full scale (full scale as defined by upstream transducer) ±(0.01 % of reading or 0.003 % Q-RPT span, whichever is greater) ±0.06 % of full scale (full scale as defined by upstream transducer)
[1] With regular use of AutoZero. Add 0.005 % of Q-RPT span for one year without use of AutoZero.		

## Temperature Measurement Specifications

Specifications are for molbloc mounted Platinum Resistance Thermometers (PRT) combined with molbox2 resistance measurement system and temperature calculation.

Range	0 °C to 40 °C
Accuracy	±0.05 °C
Resolution	0.01 °C

The molbox2 internal resistance measurement system is automatically calibrated with reference 100 Ω and 110 Ω (±0.01 %) resistors (see [OHMIC Measurement \[Temperature\] System Verification](#)).

## MFC Control Function (Optional) Specifications

### Analog Output

Voltage Range	0.100 V dc to 6.000 V dc
Voltage Accuracy	±0.1 % FS
Voltage Resolution	0.1 mV dc
Current Range	4.01 mA to 20 mA
Current Accuracy	±0.1 % FS
Current Resolution	0.4 μA

### Analog Input

Voltage Range	0 V dc to 5.000 V dc
Min/Max Measurable Voltage	- 0.25/6.00 V dc
Voltage Accuracy	±0.1 % FS
Voltage Resolution	1 mV dc
Current Range	4 mA to 20 mA
Current Accuracy	±0.1 % FS
Current Resolution	0.4 µA

### Valve Test Point

Range	+2 to +15 V dc (in reference to -15 V dc)
Accuracy	±0.25 % FS
Resolution	2.5 mV dc

## Flow Measurement Specifications

molbox2 measures the flow through molbloc flow elements. Flow measurement specifications, calibration types, ranges and dimensions are detailed separately for each molbloc type in section [molbloc-L](#) and [molbloc-S](#). For both molbloc-L and molbloc-S elements, there are separate performance specifications given for the premium and standard calibration types. All flow measurement uncertainties are valid only for measurements in a gas for which the molbloc is calibrated, and within the range of pressures for which the calibration is specified.

The gases available for actual calibration are listed in the Fluke - Phoenix Primary Pressure and Flow Lab accredited scope that can be found on [www.fluke.com](http://www.fluke.com) or on [www.a2la.org](http://www.a2la.org).

### molbloc-L

The flow range, usable operating pressure, and absolute and differential pressure associated with molbloc-L operation depend on the molbloc used and its pressure-dependent calibration options (see [Table 3](#)).

#### Standard molbloc-L Calibrations

Measurement Update Rate	340 millisecond
Range	0 to molbloc full scale depending on gas and molbloc pressure dependent calibration type
Resolution	0.0015 % FS
Linearity	±0.05 % of reading from 10 % to 100 % FS, ±0.005 % FS under 10 % FS
Repeatability	±0.05 % of reading from 10 % to 100 % FS, ±0.005 % FS under 10 % FS
Precision <sup>[1]</sup>	±0.07 % of reading from 10 % to 100 % FS, ±0.007 % FS under 10 % FS
Stability <sup>[2]</sup> (1 year)	±0.09 % of reading from 10 % to 100 % FS, ±0.009 % FS under 10 % FS

**molbox2™/molbox2-S™**  
 Operation and Maintenance Manual

Measurement Uncertainty <sup>[3]</sup> (N2 and any molbox2 supported gas for which the molbloc in use is calibrated)	±0.2 % of reading from 10 % to 100 % FS, ±0.02 % FS under 10 % FS 1E5 molbloc ±0.5% of reading from 25 % to 100 % FS, ±0.125 % FS under 25 % FS
Measurement Uncertainty <sup>[4]</sup> (Measurement uncertainty of a gas other than N2 that Fluke has experience with but the molbloc does not have an actual gas calibration.)	±0.5 % of reading from 10 % to 100 % FS, ±0.05 % FS under 10 % FS and footnote [4].
<p>[1] Precision: Combined linearity, hysteresis, repeatability.          [2] Stability: Maximum change in zero and span over specified time period for typical molbox2 and molbloc used under typical conditions. As stability can only be predicted, stability for a specific molbloc and molbox2 should be established from experience.          [3] Measurement uncertainty (accuracy): Maximum deviation of the molbox2 flow indication from the true value of the flow through the molbloc including precision, stability and Fluke calibration standard measurement uncertainty.          [4] Any molbox2 supported gas that Fluke is accredited (for which the molbloc in use is NOT calibrated in).</p>	

**Premium molbloc-L Calibrations**

Measurement Update Rate	1 second
Range	0 to molbloc full scale depending on gas and molbloc pressure dependent calibration type
Resolution	0.0015 % FS
Linearity	±0.05 % of reading from 10 % to 100 % FS, ±0.005 % FS under 10 % FS
Repeatability	±0.05 % of reading from 10 % to 100 % FS, ±0.005 % FS under 10 % FS
Precision <sup>[1]</sup>	±0.07 % of reading from 10 % to 100 % FS, ±0.007 % FS under 10 % FS
Stability <sup>[2]</sup> (1 year)	±0.03 % of reading from 10 % to 100 % FS, ±0.003 % FS under 10 % FS
Measurement Uncertainty <sup>[3]</sup> (N2 and any molbox2 supported gas for which the molbloc in use is calibrated)	±0.125 % of reading from 10 % to 100 % FS, ±0.0125 % FS under 10 % FS  1E5 molbloc-L Premium calibration not available
<p>[1] Precision: Combined linearity, hysteresis, repeatability.          [2] Stability: Maximum change in zero and span over specified time period for typical molbox2 and molbloc used under typical conditions. As stability can only be predicted, stability for a specific molbloc and molbox2 should be established from experience.          [3] Measurement uncertainty (accuracy): Maximum deviation of the molbox2 flow indication from the true value of the flow through the molbloc including precision, stability and Fluke calibration standard measurement uncertainty.</p>	

**molbloc-L Pressure Dependent Calibration Types**

*Note*

*See the molbloc Calibration Report to determine the calibration type of the molbloc in use.*

Different pressure dependent calibration options for molbloc-L elements determine the range of operating pressures over which a molbloc can be used within its mass flow measurement specifications. The calibration option also affects the molbloc flow range and the differential pressure associated with the flow range.

Measurement uncertainty (accuracy) specifications for molbloc-L are valid only for gases with which the molbloc has been calibrated. All molbloc-L elements are calibrated for N2. Calibrations with other gases are optional. Fluke Calibration calibration capability is not maintained at all times for all gases on all molbloc designations. Check for availability before you order calibrations.

The molbloc-L pressure dependent calibration types are summarized in [Table 1](#).

**Table 1. molbloc-L Pressure Dependent Calibration Types**

Calibration Type (Calibration Name)	Operating Pressure	Nominal Differential Pressure at Max. Flow	
		1E5 molbloc	all other molblocs
Low pressure (LOP)	200 kPa to 325 kPa absolute (29 psia to 48 psia) <b>upstream</b> of molbloc	5 kPa (0.725 psi)	50 kPa (7.5 psi)
High pressure (HIP)	325 kPa to 525 kPa absolute (48 psia to 76 psia) <b>upstream</b> of molbloc	Not available	50 kPa (7.5 psi)
Downstream (DOWN)	Atmospheric pressure <b>downstream</b> of molbloc. 85 kPa to 105 kPa (12 psia to 15 psia).	12.5 kPa (1.8 psi)	80 kPa (12 psi)

*Note*

*Differential pressure values are nominal and may vary by up to 15 % with the actual molbloc used.*

molbloc-L ranges with low pressure and downstream calibrations are in [Table 2](#).

**Table 2. molbloc-L Ranges with Low Pressure and Downstream Calibrations**

GASES			molbloc-L Size and Full Scale Flow (sccm @ 0 °C)									
			SIZE 1E1	SIZE 5E1	SIZE 1E2	SIZE 2E2	SIZE 5E2	SIZE 1E3	SIZE 5E3	SIZE 1E4	SIZE 3E4	SIZE 1E5
INERT	Nitrogen	N <sub>2</sub>	10	50	100	200	500	1,000	5,000	10,000	30,000	100,000
	Argon	Ar	10	50	100	200	500	1,000	5,000	10,000	30,000	80,000
	Helium	He	10	50	100	200	500	1,000	5,000	10,000	30,000	100,000
	Sulfur Hexafluoride	SF <sub>6</sub>	10	50	100	200	500	1,000	<b>2,000</b> <b>500</b>	<b>6,000</b> <b>1,000</b>	<b>6,000</b> <b>4,000</b>	---
	Xenon	XE	10	40	80	150	400	800	<b>3,500</b> <b>500</b>	8,000	<b>11,000</b> <b>3,000</b>	<b>30,000</b> <b>20,000</b>
	Neon	Ne	10	50	100	100	500	1,000	5,000	10,000	20,000	<b>60,000</b> <b>6,000</b>
	Krypton	Kr	10	50	100	200	500	1,000	5,000	10,000	20,000	<b>70,000</b> <b>8,000</b>

**Table 2. molbloc-L Ranges with Low Pressure and Downstream Calibrations (cont.)**

GASES		molbloc-L Size and Full Scale Flow (sccm @ 0 °C)									
		SIZE 1E1	SIZE 5E1	SIZE 1E2	SIZE 2E2	SIZE 5E2	SIZE 1E3	SIZE 5E3	SIZE 1E4	SIZE 3E4	SIZE 1E5
FLAMMABLE	Butane C <sub>4</sub> H <sub>10</sub>	20	100	<b>130</b> <b>30</b>	<b>270</b> <b>50</b>	<b>670</b> <b>140</b>	2,300	<b>2,200</b> <b>1,400</b>	<b>7,000</b> <b>3,000</b>	---	---
	Ethane C <sub>2</sub> H <sub>6</sub>	20	100	200	400	1,000	2,000	<b>6,000</b> <b>1,000</b>	<b>18,000</b> <b>2,000</b>	<b>18,000</b> <b>6,000</b>	<b>60,000</b> <b>50,000</b>
	Ethylene C <sub>2</sub> H <sub>4</sub>	16	80	160	320	800	1 600	<b>7,000</b> <b>1,000</b>	16,000	<b>20,000</b> <b>5,000</b>	<b>70,000</b> <b>40,000</b>
	Hydrogen H <sub>2</sub>	20	100	200	400	1,000	2,000	10,000	20,000	60,000	200,000
	Methane CH <sub>4</sub>	16	80	160	320	800	1 600	8,000	16,000	<b>40,000</b> <b>5,000</b>	<b>120,000</b> <b>40,000</b>
	Propane C <sub>3</sub> H <sub>8</sub>	20	100	200	400	1,000	2,000	<b>3,000</b> <b>1,000</b>	<b>10,000</b> <b>2,000</b>	<b>15,000</b> <b>7,000</b>	---
	Propylene C <sub>3</sub> H <sub>6</sub>	20	100	200	400	1,000	2,000	5,000	<b>10,000</b> <b>3,000</b>	<b>15,000</b> <b>8,000</b>	---
	Acetylene C <sub>2</sub> H <sub>2</sub>	20	100	200	400	1,000	2,000	10,000	20,000	<b>25,000</b> <b>7,000</b>	<b>80,000</b> <b>20,000</b>
	isoButane iC <sub>4</sub> H <sub>10</sub> (iBtn)	20	100	200	400	700	2,000	<b>3,000</b> <b>1,000</b>	<b>10,000</b> <b>3,000</b>	<b>10,000</b> <b>9,000</b>	---
	Deuterium D <sub>2</sub>	20	100	200	400	800	2,000	10,000	20,000	50,000	<b>160,000</b> <b>16,000</b>
Natural Gas NG	20	100	200	400	900	2,000	10,000	20,000	50,000	<b>120,000</b> <b>18,000</b>	
FLUORO-CARBONS	Carbon Tetrafluoride CF <sub>4</sub>	10	50	100	200	500	1,000	<b>4,000</b> <b>600</b>	10,000	<b>12,000</b> <b>3,000</b>	<b>36,000</b> <b>25,000</b>
	Hexafluorethene C <sub>2</sub> F <sub>6</sub>	10	50	100	200	500	1,000	<b>2,000</b> <b>600</b>	<b>6,000</b> <b>1,200</b>	<b>6,000</b> <b>4,000</b>	---
	Trifluoromethane CHF <sub>3</sub>	10	50	100	200	500	1,000	<b>4,000</b> <b>600</b>	10,000	<b>12,000</b> <b>4,000</b>	<b>38,000</b> <b>30,000</b>
OTHER	Air Air	10	50	100	200	500	1,000	5,000	10,000	30,000	100,000
	Carbon Dioxide CO <sub>2</sub>	10	50	100	200	500	1,000	5,000	10,000	<b>20,000</b> <b>4,000</b>	<b>60,000</b> <b>30,000</b>
	Carbon Monoxide CO	10	50	100	200	500	1,000	5,000	10,000	30,000	100,000
	Nitrous Oxide N <sub>2</sub> O	10	50	100	200	500	1,000	5,000	10,000	<b>20,000</b> <b>4,000</b>	<b>60,000</b> <b>30,000</b>
	Octafluorocyclobutane <sup>(1)</sup> C <sub>4</sub> F <sub>8</sub>	15	<b>60</b> <b>9</b>	<b>65</b> <b>17</b>	<b>130</b> <b>34</b>	<b>330</b> <b>85</b>	<b>1,100</b> <b>175</b>	<b>1,050</b> <b>840</b>	<b>3,400</b> <b>1,700</b>	---	---
	Oxygen O <sub>2</sub>	10	50	100	200	500	1,000	5,000	10,000	30,000	80,000

See Table 3 for footnotes

molbloc-L ranges with high pressure calibrations are in [Table 3](#).

**Table 3. molbloc-L Ranges with High Pressure Calibrations**

			molbloc-L Size and Full Scale Flow (sccm @ 0 °C)									
GASES			SIZE 1E1	SIZE 5E1	SIZE 1E2	SIZE 2E2	SIZE 5E2	SIZE 1E3	SIZE 5E3	SIZE 1E4	SIZE 3E4	SIZE 1E5
INERT	Nitrogen	N <sub>2</sub>	20	100	200	400	1,000	2,000	10,000	20,000	<b>50,000</b> <b>7,500</b>	N/A
	Argon	Ar	20	100	200	400	1,000	2,000	10,000	17,000	<b>45,000</b> <b>6,000</b>	N/A
	Helium	He	20	100	200	400	1,000	2,000	10,000	20,000	65,000	N/A
	Sulfur Hexafluoride	SF <sub>6</sub>	25	<b>100</b> <b>15</b>	<b>120</b> <b>30</b>	<b>250</b> <b>50</b>	<b>600</b> <b>150</b>	<b>2,000</b> <b>300</b>	<b>2,000</b> <b>1,400</b>	<b>6,200</b> <b>2,800</b>	-- --	N/A
	Xenon	XE	20	100	150	350	650	1,700	<b>3,350</b> <b>950</b>	<b>11,000</b> <b>1,900</b>	<b>11,000</b> <b>5,700</b>	N/A
	Neon	Ne	10	100	100	200	1,000	1,000	10,000	10,000	<b>40,000</b>	N/A
	Krypton	Kr	20	100	200	300	1,000	2,000	<b>6,000</b> <b>1,000</b>	20,000	<b>20,000</b> <b>5,000</b>	N/A
FLAMMABLE	Butane	C <sub>4</sub> H <sub>10</sub>	N/A	N/A	N/A	N/A	N/A	N/A	N/A	N/A	N/A	N/A
	Ethane	C <sub>2</sub> H <sub>6</sub>	40	200	<b>350</b> <b>50</b>	<b>700</b> <b>100</b>	<b>1,800</b> <b>200</b>	4,000	<b>6,000</b> <b>2,300</b>	<b>20,000</b> <b>4,500</b>	<b>20,000</b> <b>13,000</b>	N/A
	Ethylene	C <sub>2</sub> H <sub>4</sub>	40	200	350	700	2,000	4,000	<b>7,000</b> <b>2,000</b>	<b>22,000</b> <b>4,000</b>	<b>22,000</b> <b>12,700</b>	N/A
	Hydrogen	H <sub>2</sub>	40	200	400	900	2,000	4,500	22,000	45,000	130,000	N/A
	Methane	CH <sub>4</sub>	35	175	350	700	1,700	3,500	<b>13,000</b> <b>2,000</b>	33,000	<b>42,000</b> <b>12,000</b>	N/A
	Propane	C <sub>3</sub> H <sub>8</sub>	50	<b>200</b> <b>25</b>	<b>200</b> <b>50</b>	<b>400</b> <b>100</b>	<b>1,000</b> <b>250</b>	<b>3,500</b> <b>500</b>	<b>3,500</b> <b>2,600</b>	<b>11,000</b> <b>5,400</b>	-- --	N/A
	Propylene	C <sub>3</sub> H <sub>6</sub>		100	200	400	1,000	2,000	5,000	<b>10,000</b> <b>3,000</b>	<b>15,000</b> <b>8,000</b>	--- ---
	Acetylene	C <sub>2</sub> H <sub>2</sub>		100	200	400	1,000	2,000	10,000	20,000	<b>25,000</b> <b>7,000</b>	<b>80,000</b> <b>20,000</b>
	isoButane	iC <sub>4</sub> H <sub>10</sub> (iBtn)	N/A	N/A	N/A	N/A	N/A	N/A	N/A	N/A	N/A	N/A
	Deuterium	D <sub>2</sub>	30	200	300	600	2,000	3,000	20,000	20,000	50,000	<b>160,000</b> <b>16,000</b>
Natural Gas	NG	20	200	300	700	2,000	3,000	<b>13,000</b> <b>2,000</b>	40,000	<b>40,000</b> <b>10,000</b>	<b>120,000</b> <b>18,000</b>	
FLUORO-CARBONS	Carbon Tetrafluoride	CF <sub>4</sub>	30	100	200	400	1,000	2,000	<b>3,700</b> <b>1,200</b>	<b>12,000</b> <b>2,400</b>	<b>12,000</b> <b>7,300</b>	N/A
	Hexafluorethene	C <sub>2</sub> F <sub>6</sub>	25	<b>100</b> <b>15</b>	<b>120</b> <b>30</b>	<b>250</b> <b>50</b>	<b>600</b> <b>150</b>	<b>2,000</b> <b>300</b>	<b>1,800</b> <b>1,500</b>	<b>6,000</b> <b>3,000</b>	-- --	N/A
	Trifluoromethane	CHF <sub>3</sub>	25	125	<b>240</b> <b>30</b>	<b>450</b> <b>60</b>	<b>1,200</b> <b>150</b>	2,500	<b>4,000</b> <b>1,500</b>	<b>12,000</b> <b>3,000</b>	<b>12,000</b> <b>8,800</b>	N/A

**Table 3. molbloc-L Ranges with High Pressure Calibrations (cont.)**

GASES		molbloc-L Size and Full Scale Flow (sccm @ 0 °C)										
		SIZE 1E1	SIZE 5E1	SIZE 1E2	SIZE 2E2	SIZE 5E2	SIZE 1E3	SIZE 5E3	SIZE 1E4	SIZE 3E4	SIZE 1E5	
OTHER	Air	Air	20	100	200	400	1,000	2,000	10,000	20,000	<b>50,000</b> <b>7,200</b>	N/A
	Carbon Dioxide	CO <sub>2</sub>	25	125	250	500	1,250	2,500	<b>6,600</b> <b>1,400</b>	<b>20,000</b> <b>2,500</b>	<b>20,000</b> <b>8,800</b>	N/A
	Carbon Monoxide	CO	20	100	200	400	1,000	2,000	10,000	20,000	40,000 7,500	N/A
	Nitrous Oxide	N <sub>2</sub> O	25	125	250	500	1,250	2,500	<b>11,000</b> <b>1,500</b>	<b>20,000</b> <b>3,000</b>	<b>20,000</b> <b>9,000</b>	N/A
	Octafluorocyclobutane	C <sub>4</sub> F <sub>8</sub>	N/A	N/A	N/A	N/A	N/A	N/A	N/A	N/A	N/A	N/A
	Oxygen	O <sub>2</sub>	20	100	200	400	1,000	2,000	10,000	20,000	<b>40,000</b> <b>6,500</b>	N/A

A **bold value** indicates that the maximum flow is limited by the maximum Reynolds number value of 1200 (1550 for 3E4-L) which is reached before the normal differential pressure range is reached. In that case, the second value gives the minimum flow for which measurement uncertainty (accuracy) is equal to the nominal uncertainty specification.

Where there is no value in the field (--), this indicates that the maximum Reynolds number is reached before the differential pressure reaches 5 kPa (1 kPa in the case of the 1E5 molbloc), therefore calibration with that gas is not useful.

[1] Due to low vapor pressure, only downstream calibration type is available.

[2] The operating pressure range is greater than the vapor pressure value for this gas.

molbloc-L Dimensions are in [Table 4](#).

**Table 4. molbloc-L Dimensions**

molbloc-L Sizes [mm(in.)]			
5E3 AND LOWER		5E3 AND LOWER	
<b>A</b>	58.50 (2.303)	A	58.50 (2.303)
<b>B</b>	16.00 (0.630)	B	16.00 (0.630)
<b>C</b>	32.00 (1.260) SQ	C	32.00 (1.260) SQ
<b>D</b>	68.84 (2.750)	D	68.84 (2.750)
<b>E</b>	19.06 (0.750)	E	19.06 (0.750)
<b>F</b>	124.00 (4.881)	F	124.00 (4.881)
<b>G</b>	1/4 in. VCR M	G	1/4 in. VCR M

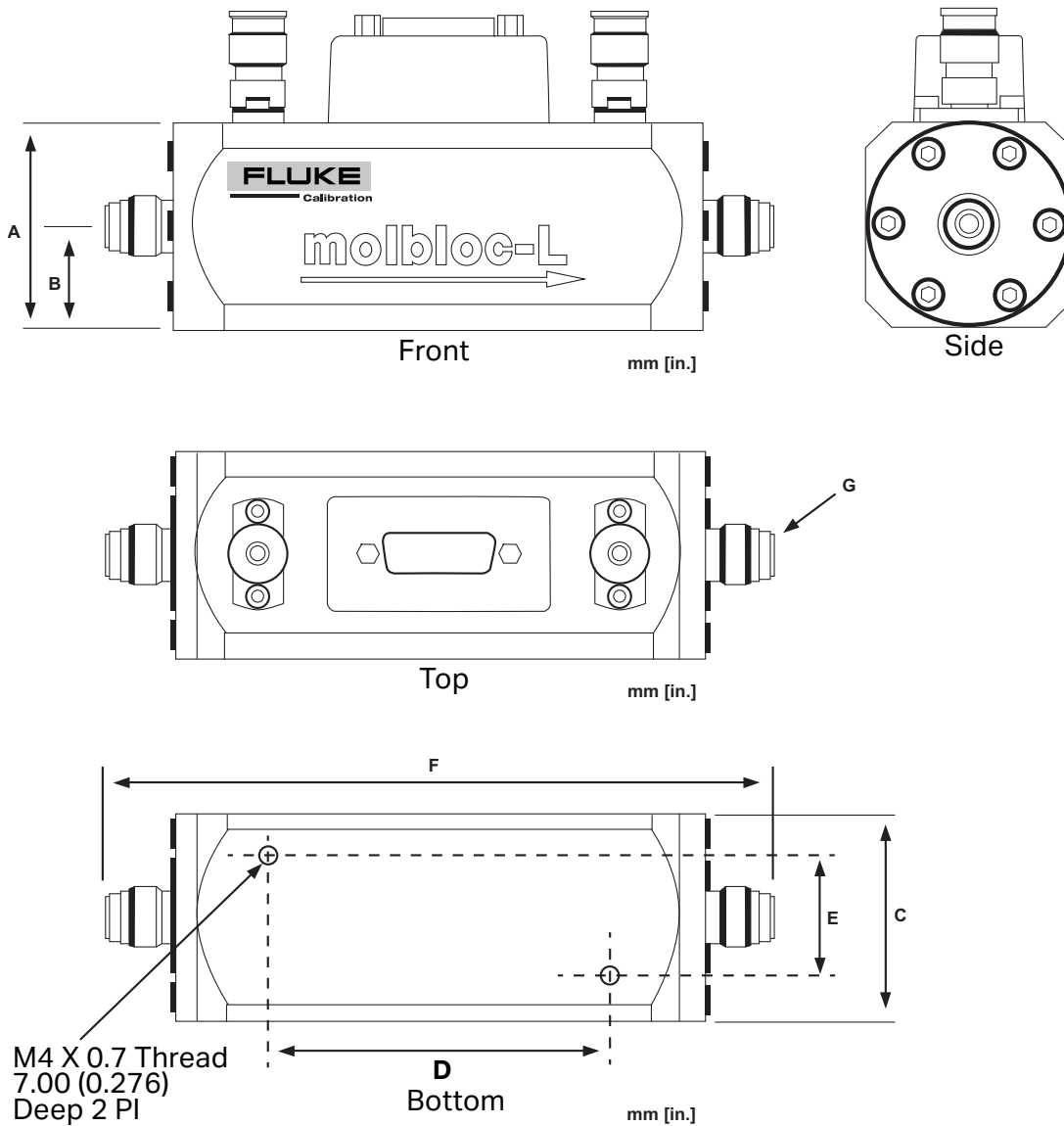

### molbloc-S

The flow range and operating pressure associated with molbloc-S operation depend on the molbloc and molbox used and the molbloc calibration option selected (see [molbloc-S Pressure Dependent Calibration Types](#)).

Standard molbloc-S calibrations are in [Table 5](#).

**Table 5. Standard molbloc-S Calibrations**

Measurement Update Rate	340 ms	
Range	Depends on molbloc-S pressure dependent calibration type (see <a href="#">Standard molbloc-S calibrations are in Table 5</a> .)	
Resolution	0.0015 % of FS	
Linearity	±0.05 % of reading	
Repeatability	±0.05 % of reading	
Precision <sup>[1]</sup>	±0.06 % of reading	
Predicted Stability <sup>[2]</sup> (1 year)	±0.05 % of reading	
Measurement Uncertainty <sup>[3]</sup> With SP molbloc-S calibration	<b>A350K</b> <b>A700K</b> <b>S A1.4M</b>  <b>S A2M</b>	±0.2 % of reading from 50 kPa to 200 kPa ±0.2 % of reading from 50 kPa to 600 kPa ±0.2 % of reading from 100 kPa to 600 kPa ±0.2 % of 100 kPa flow from 50 kPa to 100 kPa ±0.2 % of reading from 200 kPa to 600 kPa ±0.2 % of 200 kPa flow from 50 kPa to 200 kPa
Measurement Uncertainty <sup>[3]</sup> With LP molbloc-S calibration	<b>A350K</b> <b>A700K</b>	± 0.2 % of reading from 20 kPa to 200 kPa ± 0.2 % of reading from 20 kPa to 200 kPa
Measurement Uncertainty <sup>[3]</sup> With HP molbloc-S calibration	<b>A700K</b> <b>S A1.4M</b> <b>S A2M</b>	± 0.2 % of reading from 200 kPa to 600 kPa ± 0.2 % of reading from 200 kPa to 1.2 MPa ± 0.2 % of reading from 200 kPa to 2 MPa
<p>[1] Precision: Combined linearity, hysteresis, repeatability.                  [2] Stability: Maximum change in zero and span over specified time period for typical molbox2 and molbloc used under typical conditions. As stability can only be predicted, stability for a specific molbloc and molbox2 should be established from experience.                  [3] Measurement uncertainty: Maximum deviation of the molbox2 flow indication from the true value of the flow through the molbloc including precision, stability and FLUKE calibration standard measurement uncertainty.</p>		

Premium molbloc-S Calibrations are in [Table 6](#).

**Table 6. Premium molbloc-S Calibrations**

Measurement Update Rate	340 ms	
Range	Depends on molbloc-S pressure dependent calibration type (see <a href="#">Premium molbloc-S Calibrations are in Table 6</a> .)	
Resolution	0.0015 % of FS	
Linearity	±0.05 % of reading	
Repeatability	±0.05 % of reading	
Precision <sup>[1]</sup>	±0.06 % of reading	
Predicted Stability <sup>[2]</sup> (1 year)	±0.03 % of reading	
Measurement Uncertainty <sup>[3]</sup> With SP molbloc-S calibration	<b>A350K</b> <b>A700K</b> <b>S A1.4M</b>  <b>S A2M</b>	±0.125 % of reading from 50 kPa to 200 kPa ±0.125 % of reading from 50 kPa to 600 kPa ±0.125 % of reading from 100 kPa to 600 kPa ±0.125 % of 100 kPa flow from 50 kPa to 100 kPa ±0.125 % of reading from 200 kPa to 600 kPa ±0.125 % of 200 kPa flow from 50 kPa to 200 kPa
Measurement Uncertainty <sup>[3]</sup> With LP molbloc-S calibration	<b>A350K</b> <b>A700K</b>	± 0.125 % of reading from 20 kPa to 200 kPa ± 0.125 % of reading from 20 kPa to 200 kPa ± 0.125 % of 50 kPa flow from 20 kPa to 50 kPa
Measurement Uncertainty <sup>[3]</sup> With HP molbloc-S calibration	<b>A700K</b> <b>S A1.4M</b> <b>S A2M</b>	± 0.125 % of reading from 200 kPa to 600 kPa ± 0.125 % of reading from 200 kPa to 1.2 MPa ± 0.125 % of reading from 200 kPa to 2 MPa
<p>[1] Precision: Combined linearity, hysteresis, repeatability.                  [2] Stability: Maximum change in zero and span over specified time period for typical molbox2 and molbloc used under typical conditions. As stability can only be predicted, stability for a specific molbloc and molbox2 should be established from experience.                  [3] Measurement uncertainty: Maximum deviation of the molbox2 flow indication from the true value of the flow through the molbloc including precision, stability and Fluke calibration standard measurement uncertainty.</p>		

## molbloc-S Pressure Dependent Calibration Types

### Note

See your molbloc Calibration Report to determine the calibration type of the molbloc in use.

Measurement uncertainty (accuracy) specifications for molblobs are valid only for gases with which the molbloc has been calibrated. All molbloc-S elements are calibrated in one standard gas, either air or N<sub>2</sub>, and may be calibrated in other gases. Calibrations with other gases are optional. The list of gases which can be measured by molbloc-S is the same as molbloc-L. Fluke Calibration calibration capability is not maintained at all times for all gases on all molbloc designations. Check for availability before you order calibrations.

molbloc-S calibrations are done over flow ranges that correspond to one of three pressure ranges, summarized in [Table 7](#).

**Table 7. molbloc-S Calibration Types**

Calibration Type (Calibration Name)	Operating Pressure
Low pressure (LP)	20 kPa to 200 kPa absolute (3 psia to 30 psia) <b>upstream</b> of molbloc
Standard pressure (SP)	50 kPa to 600 kPa absolute (7 psia to 70 psia) <b>upstream</b> of molbloc
High pressure (HP)	200 kPa to 2000 kPa absolute (29 psia to 290 psia) <b>upstream</b> of molbloc

### Note

*molbloc-S flow measurements are valid only when the ratio of pressure downstream to the pressure upstream of the nozzle is low enough to assure a critical (choked) flow (see [molbloc-S BPR Limits](#)).*

## molbloc-S Ranges

See [Table 44](#) at the end of this manual for molbloc-S flow ranges. molbloc-S flow ranges are defined by the molbloc Pressure to Flow Conversion Ratio,  $K_F$ , the gas used, the absolute pressure that can be delivered upstream of molbloc-S, the downstream pressure and the acceptable back pressure ratio (see [molbloc-S BPR Limits](#)).  $K_F$  is expressed in units of sccm/kPa and defines the relationship between mass flow in nitrogen and the absolute upstream pressure delivered to the molbloc-S. molbloc-S sizes are defined by the nominal  $K_F$  of the molbloc-S nozzle, with scientific notation, for example a 1E3 molbloc-S has a  $K_F$  of 1000 sccm/kPa. To differentiate from molbloc-L size designations, this molbloc size is designated as 1E3-S.

The molbox2 pressure range, the molbloc-S calibration type (see [Premium molbloc-S Calibrations are in Table 6](#).) and the back pressure ratio (BPR) requirements limit the pressures, and flows, over which a molbloc-S can be used within known measurement uncertainty limits. In practice, the usable range of a molbloc-S in a given application also may depend on the available gas supply pressure, the presence and flow capacity of a vacuum pump downstream or the allowable back pressure on an upstream Device Under Test (DUT).

The mass flow range of a molbloc-S element depends on the properties of the gas used, so the range of a molbloc-S is different for each supported gas. The flow ranges for each molbloc-S size at various typical operating pressures are summarized separately for each molbloc-S supported gas in the tables below. For the common application of using a molbloc-S with its downstream pressure at or near atmospheric pressure, it is helpful to know what minimum flow can be measured before violating back pressure ratio requirements (see [molbloc-S BPR Limits](#)). In [Table 44](#), at the end of this manual, this minimum flow value is given in the no vacuum row.

Fluke Calibration calibration capability may not be available for some of the gases listed, or may be limited to <maximum flow rate listed. Check for availability before you order calibrations.

These notes apply to the ranges for the upstream pressure tables below:

Ratio = Inverse square root density ratio of the current gas to Nitrogen

KF = Pressure to Flow Conversion Ratio, sccm/kPa

[Table 44](#) (at the end of this manual) shows gases that were supported for calibration when this document was released. To calculate the flow rates for other gases, or at different pressures, use this formula:

$$Kf \times \text{Ratio} \times (\text{Pressure in kPa absolute}/1000)$$

[Table 8](#) shows known ratios for various gases to help in these calculations. For example, in the [Table 44](#) you see the 1E1-S has a Kf =10 and N2 has a Ratio = 1.00. The minimum pressure for Low Pressure (LP) (with vacuum) is 20 kPa per the corresponding footnote. So, the formula is 1.00 x 10 x (20/1000) which would equal the 0.2 value shown in the upper left most table values in [Table 44](#).

**Table 8. Gas Ratios**

Gas		Ratio
Nitrogen	N2	1.000
Air	Air	0.983
Argon	Ar	0.837
Helium	He	2.647
Carbon Dioxide	CO2	0.795
Sulfur Hexafluoride	SF6	0.435
Xenon	Xe	0.460
Butane	C4H10	0.680
Ethane	C2H6	0.960
Ethylene	C2H4	0.996
Hydrogen	H2	3.730
Methane	CH4	1.320
Propane	C3H8	0.789
Carbon Tetrafluoride	CF4	0.563
Hexafluoroethene	C2F6	0.447
Trifluoromethane	CHF3	0.629
Carbon Monoxide	CO	1.000
Nitrous Oxide	N2O	0.795
Octafluorocyclobutane1	C4F8	0.367
Oxygen	O2	0.935
Neon	Ne	1.179
Krypton	Kr	0.578

**Table 8. Gas Ratios (cont.)**

Gas	Ratio
Propylene	C3H6 0.808
Acetylene	C2H2 1.033
isoButane	iC4H10 (iBtn) 0.682
Deuterium	D2 2.639
Natural Gas	NG 1.276

molbloc-S Dimensions are in [Table 9](#).

**Table 9. molbloc-S Dimensions**

	molbloc-S SIZE [mm(in.)]				
	1E2-S and lower	2E2-S through 1E3-S	2e3-S	5e3-S	1e4-S
<b>A</b>	48.0(1.89) SQ	48.0 (1.89) SQ	48.0(1.89) SQ	80.0 (3.15) SQ	80.0 (3.15) SQ
<b>B</b>	24.0(0.94)	24.0 (0.94)	24.0(0.94)	40.0 (1.57)	40.0 (1.57)
<b>C</b>	48.0(1.89) SQ	48.0 (1.89) SQ	48.0(1.89) SQ	80.0 (3.15) SQ	80.0 (3.15) SQ
<b>D</b>	80.0(3.15)	80.0 (3.15)	80.0(3.15)	176.0 (6.93)	176.0 (6.93)
<b>E</b>	28.0(1.10)	28.0 (1.10)	28.0(1.10)	44.0 (1.73)	44.0 (1.73)
<b>F</b>	167.5 (6.59)	171.0 (6.73)	175.0 (6.89) <sup>[1]</sup>	299.7 (11.80) <sup>[1]</sup>	331.0 (13.03) <sup>[1]</sup>
<b>G</b>	KF16 FLANGE	KF16 FLANGE	KF16 FLANGE	KF40 FLANGE	KF40 FLANGE
<b>H</b>	100.0 (3.94)	84.0 (3.31)	84.0(3.31)	154.0 (6.06)	154.0 (6.06)
<b>I</b>	128.0 (5.04)	128.0 (5.35)	128.0 (5.35)	236.0 (9.29)	236.0 (9.29)
<b>J</b>	73.0(2.87)	73.0 (2.87)	73.0(2.87)	106.0 (4.17)	106.0 (4.17)
<b>K</b>	167.5 (6.59)	171.0 (6.73)	171.0 (6.73)	290.0 (11.42)	290.0 (11.42)
<b>L</b>	¼ in. VCR Male <sup>[2]</sup>	½ in. VCR M <sup>[2]</sup>	½ in. VCR M <sup>[2]</sup>	KF25 FLANGE <sup>[2]</sup>	KF25 FLANGE <sup>[2]</sup>
<p>[1] On some molbloc-S elements, the venturi nozzle extends beyond the molbloc downstream flange, making the overall length dimension, F, longer than the fitting to fitting length dimension, K. The nozzle overhang may interfere with some molbloc-S downstream connections or the connection of a blank off cap for leak testing, so a 40 mm diameter ISO-KF nipple is supplied with 5E3-S and 1E4-S molblobs.</p> <p>[2] Default connector type is listed. Additional upstream connector options may be available. Contact your FLUKE Sales Representative for details.</p>					

**molbox2™/molbox2-S™**  
 Operation and Maintenance Manual

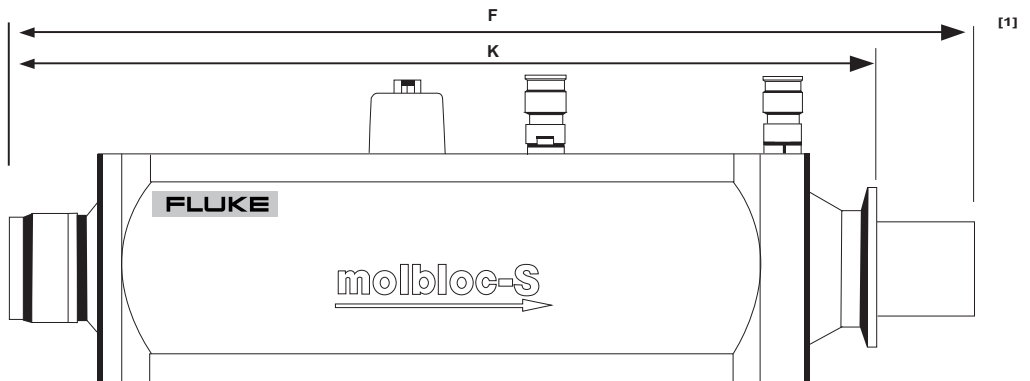
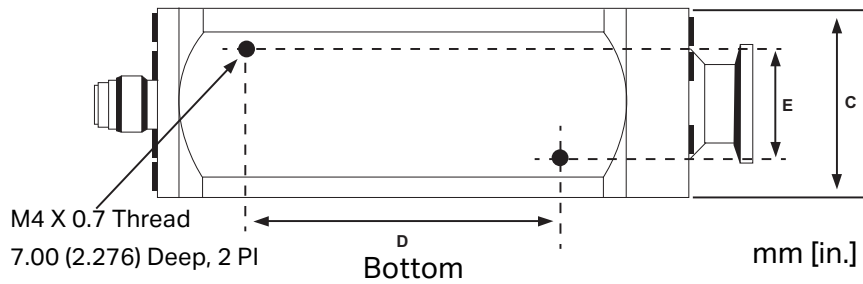
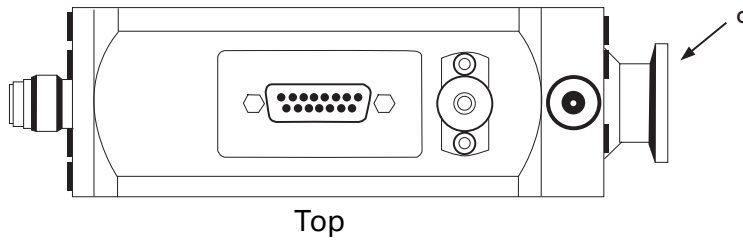
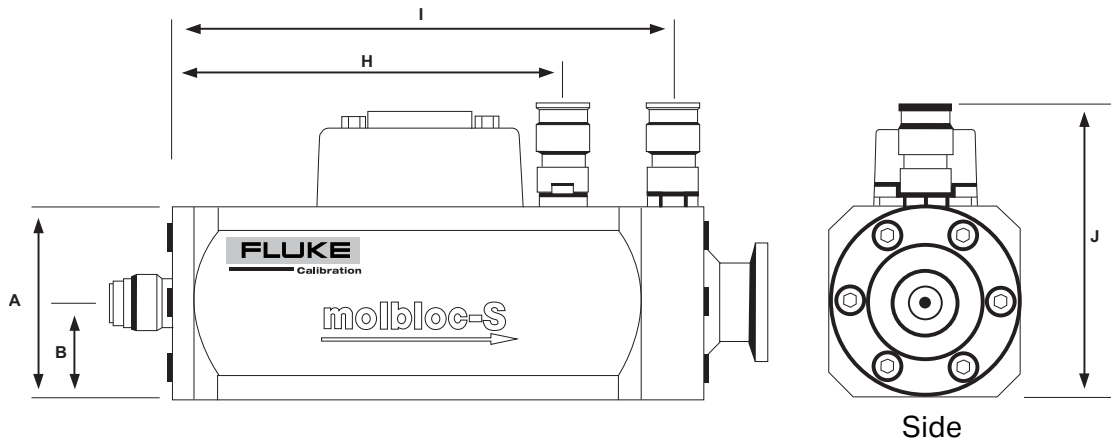

## Front Panel

The front panel provides a 2 x 20 vacuum fluorescent display, a membrane keypad for local user interface and other LED indicators. See [Table 10](#).

**Table 10. Front Panel**

Item	Description	Item	Description
1	2 x 20 Display	3	Channel Indicator
2	Multi-Function Keypad	4	Remote Operation Indicator

## Rear Panel

The rear panel provides pressure and electrical connections for two molbloc mass flow elements, communications interfaces, and the power connection module.

**Table 11. Rear Panel**

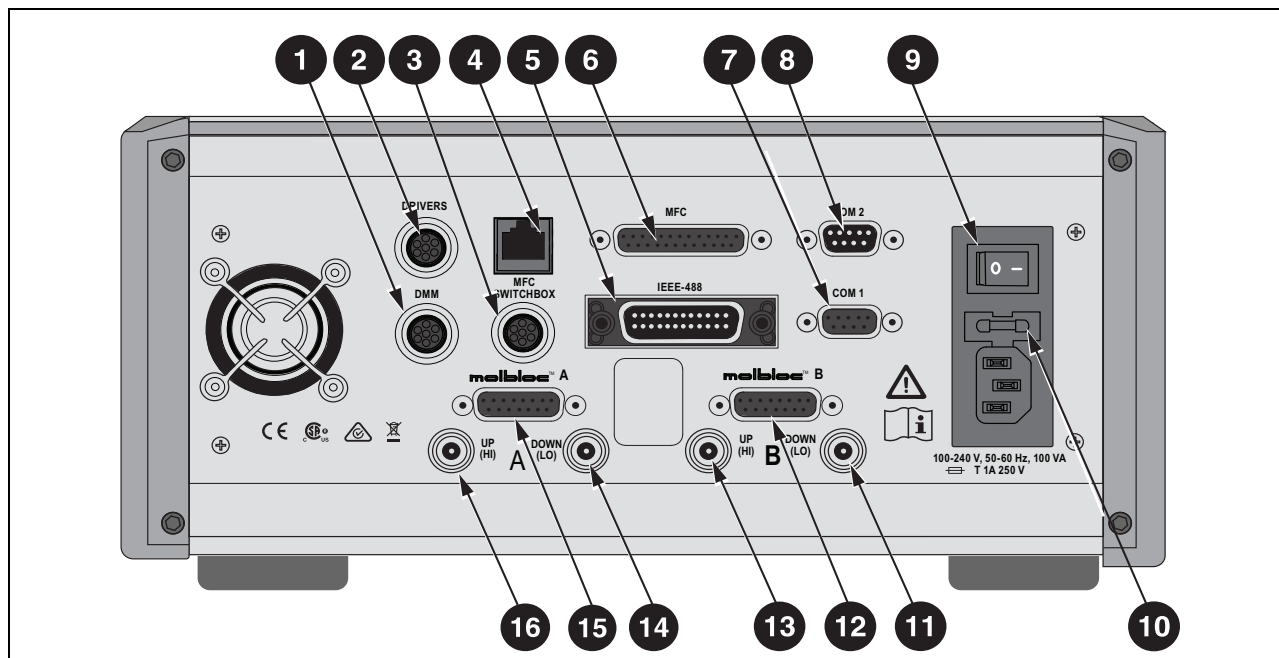

Item	Description	Item	Description
1	Connection for External DMM (Option)	9	On/Off Switch
2	External Drivers Connection (Option)	10	Fuse
3	MFC Switchbox Connection	11	molbloc LO Pressure Connections (Channel B)
4	RS485 Connection (not used)	12	molbloc Electrical Connection (Channel B)
5	Host Communications (IEEE-488)	13	molbloc HI Pressure Connections (Channel B)
6	MFC Analog Control Connection	14	molbloc LO Pressure Connections (Channel A)
7	Host Communications (RS232)	15	molbloc Electrical Connection (Channel A)
8	Remote Communication for External Device (RS232)	16	molbloc HI Pressure Connections (Channel A)

## Installation

### Unpack and Inspect the Product

#### Remove from Package

molbox2 is delivered, along with its standard accessories, in a corrugated container with foam end caps to hold it in place.

Remove the molbox2 and its accessories from the shipping container and remove each element from its protective plastic bag.

#### Inspect the Contents

Make sure that all items are present and have no visible damage. molbox2 includes the items in [Table 12](#) and [Table 13](#).

**Table 12. molbox2 Parts List (without MFC option)**

Fluke Part Number	Qty	Description
VARIABLES	1	MOLBOX2-MASS FLOW TERMINAL
3069560	1	PLINE-401125,PRESSURE LINE, MOLBOX TO MOLBLOC (SET OF 2)
6078270	1	MOLBOX2-4202,KIT, ACCY, MOLBOX2
4867897	2	CBL-MBLOC-3M-CE,CABLE, MOLBOX TO MOLBLOC, DB15M-DB15F, 3M, CE
3068652	2	QC-101889,QUICK CONNECTOR, 1/8 IN SWGM FOR SWG QCH
3069838	1	401382,DRIVERS CONNECTOR, EXT 12V (8)
3136885	1	102478,CONN, 12 PIN, M DIN
3152121	1	550100,CALIBRATION CERTIFICATE
6077998	1	MOLBOX2,SAFETY INFORMATION
VARIABLES	1	LINE CORD

**Table 13. molbox2 Parts List (with MFC option)**

<b>Fluke Part Number</b>	<b>Qty</b>	<b>Description</b>
VARIABLES	1	MOLBOX2-MASS FLOW TERMINAL, MFC CTRL
3069560	1	PLINE-401125,PRESSURE LINE, MOLBOX TO MOLBLOC (SET OF 2)
6078270	1	MOLBOX2-4202,KIT, ACCY, MOLBOX2
4867897	2	CBL-MBLOC-3M-CE,CABLE, MOLBOX TO MOLBLOC, DB15M-DB15F, 3M, CE
3068652	2	QC-101889,QUICK CONNECTOR, 1/8 IN SWGM FOR SWG QCH
3069838	1	401382,DRIVERS CONNECTOR, EXT 12V (8)
3136885	1	102478,CONN, 12 PIN, M DIN
3152121	1	550100,CALIBRATION CERTIFICATE
6077998	1	MOLBOX2,SAFETY INFORMATION
VARIABLES	1	LINE CORD
3114784	1	401620-CE,KIT, MFC OPT CABLES, CE
3072321	1	401230-CE,CABLE, MFC W/CONNECTOR KIT, CE
3153776	1	102479-CE,CBL, MOLBOX1-95 MFC CE
3125358	1	401261,KIT,MOLBOX1 MFC CBL CMN
3136872	1	102477,CONN, 3 PIN, M DIN
3137027	1	CONNECTOR,D-SUB,.109IN,CABLE MOUNT,SOLDER UP,9 SOCKET,BULK
3144709	1	103983,BACKSHELL,CONN,15 PIN D-SUBMINIATURE
757468	1	CONNECTOR PART ,CONN PART,D-SUB,PLUG HOUSING,15 POS
3152493	1	560018,INSTR, MFC CABLE REF
4866951	2	FERRITE CLAMP,220 OHM AT 300MHZ,ID 0.400,OD 0.877WX0.860HX1.290L
3069720	1	401256,CABLE, MOLBOX1/MFC-CB ANALOG CAL

## Site Requirements

Install the Product on any stable surface at a convenient height. The front feet can extend so that the Product inclines for easier viewing.

When you install the molbox2, consider where the molbloc flow measuring element and associated hardware will be located. You can place the Product on a shelf or cart at a different height than the molbloc, but the distance between the molbloc and molbox is limited by the length of the cable and pneumatic lines that connect them. If you will locate the molbox at a different height than the molbloc, the small errors that would be associated with the difference in pressure can be removed with the molbox2 head correction (see [<8Head>](#)).

To calibrate other devices under test (DUTs), the molbloc may need to be connected upstream or downstream of the DUT to operate within the pressure limits of the molbloc calibration type (see [molbloc-S Pressure Dependent Calibration Types](#)) and to accommodate the pressure requirements of the DUT. See the molbloc Calibration Report to determine the calibration type of the molbloc in use.

If the molbloc is upstream from the DUT, it is important to supply the molbloc with a stable regulated gas source. Minimize the volume present between the molbloc and the device to be calibrated, particularly for low flows.

In some cases, molbloc-S is used with a vacuum source downstream to reduce the pressure at which critical flow is reached. Consider the placement of the vacuum pump and connections. Generally, a large vacuum pump is needed and should be isolated from the work area due to noise and oil vapor considerations. If the vacuum pump and/or vacuum kit was purchased from Fluke Calibration, see the instruction sheets and/or manuals that are included with the hardware.

Optional molstics are offered to mount molblobs. They can provide supply regulation, filtering, and interconnection issues with high quality, configured hardware. For additional information, contact your Fluke Calibration representative

### Caution

**If a DUT is located upstream of the molbloc and is contaminated, contaminants can flow from the DUT to the molbloc and alter the molbloc calibration. If the DUT must be connected upstream of the molbloc, be sure it is clean before flowing and consider installing a filter between the DUT and the molbloc.**

## Initial Setup

### Prepare for Operation

To prepare molbox2 for check out and operation:

1. Read the printed *Safety Information* that came with the Product.
2. Remove the plastic caps from the rear panel pressure connections.
3. Remove the protective plastic sheet from the front-panel display.
4. Familiarize yourself with the front and rear panels (see [Specifications](#) and [Rear Panel](#)).
5. Follow the steps in [Power Connection](#) to [MFC Control Option Connection](#).

## Power Connection

Connect the supplied power cable to molbox2 and to a power source. Power requirements are 100 V ac to 240 V ac, 50 Hz to 60 Hz, 100 VA max. consumption.

## molbox2 to molbloc Connections

The Product has two molbloc connection channels. Each has two pressure connections (upstream and downstream) and one electrical/data connection. Select a channel to use or connect a separate molbloc to each channel.

For the pressure connections:

1. Use molbloc pressure tubes (PN 3069560) supplied with the molbox2 and follow the color coding on the pressure lines to connect the upstream (HI) molbox2 rear panel quick connector.
2. Connect to the upstream port of the molbloc.
3. Connect the downstream (LO) quick connector to the downstream port.

To connect the quick connectors:

1. Pull back the knurled sleeve on the quick connector body.
2. Insert the quick connector stem and push firmly on the quick connectors until they click into place to assure that the connection is completed.
3. For the electrical/data connection, use the molbox to molbloc electrical/data connection cable (P/N 3068683). Connect the cable to the molbloc and then to molbox2 rear panel connector labeled molbloc.

### **Caution**

**Do not make or break molbloc electrical connections to the molbox2 while the molbox2 power is ON. Damage to the molbloc EEPROM may result.**

## Gas Supply and Flowpath Connections

Connect a gas supply to the molbloc. Gas supply requirements are:

- The gas supply must be clean and dry (especially free from oil and particulates) to avoid contaminating the molbloc.
- For correct measurements, the gas must be of the same type as that selected by the GAS function (see [\[GAS\]](#)). Gas purity affects the measurement uncertainty of flow measurements as molbox2 uses the thermodynamic properties of the flowing gas in its flow calculations. Generally, gases with purity of 99.9 % or better are used for molbloc measurements. Except when using ambient air with molbloc-S, the test gas should be free of any humidity (dewpoint <- 40 °C).

- If the molbloc is connected upstream of the DUT, the supply pressure must be regulated and stable within the limits of the molbloc-L pressure dependent calibration type (see [molbloc-L Pressure Dependent Calibration Types](#)) or molbloc-S calibration type (see [molbloc-L ranges with low pressure and downstream calibrations are in Table 2.](#)). If the molbloc is connected downstream of the DUT, use regulators and valves to make sure that the pressure that is delivered to the molbloc will be within the limits of the molbloc calibration type.
- Make sure that the pressure and flow supplied to the molbloc are always low enough to avoid over pressuring the molbox2 RPTs (see [Reference Pressure Transducer \(RPT\) Specifications](#) and [Reference Pressure Transducer \(RPT\) Overpressure](#)). If a DUT upstream of the molbloc is operated at high pressure, connect a pressure reducing regulator between the DUT and the molbloc to ensure that even momentary high pressure spikes do not reach the molbox2 RPTs.

**⚠ Caution**

- **The gas supplied to the molbloc should be clean and dry. Contamination of the molbloc flow passage with liquids, particulates, or any other matter alters the molbloc calibration and can lead to out of tolerance flow measurements.**
- **Do not connect a pressure source to the molbloc that is greater than the overpressure limit of your molbox2. A350K overpressure limit is 300 kPa absolute/200 kPa gauge (44 psig/29 psig). molbox2 A700K overpressure limit is 650 kPa absolute/550 kPa gauge (95 psia/80 psig). Overpressure can damage the Product internal RPTs (see Section [Reference Pressure Transducer \(RPT\) Specifications](#), [Reference Pressure Transducer \(RPT\) Overpressure](#)).**

**If using a Fluke Calibration molstic:**

Install the molbloc into the molstic and connect a gas supply. Follow the molstic instruction sheet or manual. The flow through the molbloc must be in the direction of the arrow engraved on the molbloc.

**If NOT using a Fluke Calibration molstic:**

Connect a gas supply to the molbloc according to the *Recommendations for molbloc Installation* instruction sheet, Fluke document PN 3152446, and the pressure limits of the molbloc calibration type.

Install a valve between the pressure supply and the molbloc to allow flow to the molbloc to be interrupted. The flow through the molbloc must be in the direction of the arrow engraved on the molbloc.

Adapter kits are available from Fluke Calibration to make connections from the molbloc or molstic fittings to other common connector types. Ask your Fluke Calibration sales representative about specific adapter requirements.

**⚠ Caution**

**Operation at pressures other than those of the molbloc-L pressure dependent calibration type (see [Premium molbloc-L Calibrations](#)) or molbloc-S calibration type may result in out of tolerance flow measurements. Refer to the molbloc Calibration Report to determine its calibration type.**

**Vacuum Supply (molbloc-S only)**

In some cases, molbloc-S operates with a vacuum downstream of the molbloc to reduce the back pressure so that critical flow can be reached at a lower upstream pressure (see [molbloc-S BPR Limits](#)).

There is no lower limit to the pressure that may safely be applied to molbox2 RPTs.

**If using a Fluke Calibration supplied downstream vacuum connect kit and vacuum pump:**

Install the kit and pump. Follow the supplied instruction sheet or manual. Carefully follow the pump manufacturer recommendations for pump operation.

**If NOT using Fluke Calibration supplied downstream vacuum connect kit and vacuum pump:**

Carefully evaluate vacuum pump specifications to be sure that the vacuum source available has the pumping speed necessary to safely handle the planned flows and to maintain low enough pressure at planned flow rates.

Be sure to provide facilities to avoid flowing into the pump when the pump is not ON as this will cause pressure to build up and can damage the pump. Normally, a shut-off valve should be included between the pump and the molbloc-S.

It is preferable to install a check valve with very low cracking pressure between the molbloc and the vacuum shut-off valve.

Adapter kits are available from Fluke Calibration to make connections from the molbloc or molstic fittings to other common connector types. Ask your Fluke Calibration sales representative about your specific adapter requirements.

**⚠ Caution**

**Operation at pressures other than those of the molbloc-S calibration type can result in out of tolerance flow measurements (see [Premium molbloc-L Calibrations](#)). Refer to the molbloc Calibration Report to determine its calibration type.**

**Communications Connections**

To connect the Product to a computer:

1. Connect an RS232 cable to COM1 or an IEEE-488 cable (cables not supplied) to the molbox2 IEEE-488 interface.
2. Configure the interface (see [6REMOTE](#)).

## MFC Control Option Connection

If the Product is has the MFC control option, a cable and connection kit was supplied with the accessories. Use the pinout information provided in [MFC Control Function-MFC Connector](#) and information from the MFC manufacturer to correctly configure the cable.

## Power Up and Verification

### Power Up

Push the power switch on the rear panel. Observe the front-panel display as molbox2 initializes, error checks, calibrates its internal ohmic measurement system and goes to the main run screen (see [Main Run Screen](#)). The top left side of the main run screen should show a flow value near zero or <BPR HI>. If <NO BLOC> shows, molbox2 has not been able to identify a molbloc connection and load molbloc information. Make sure that a valid molbloc is properly connected (see [molbox2 to molbloc Connections](#)) and push **SETUP**, <1molbloc> to load the molbloc (see [<1molbloc>](#)). If molbox2 is unable to identify a molbloc, the molbloc might require reloading of EEPROM information or might require repair.

If the molbox2 fails to reach the main run screen, service might be required. Record the sequence of operations and displays observed and contact a Fluke Calibration authorized service provider.

### Check Proper Pressure Measurement Operation

Make sure that the pressure measurements operate properly.

1. Connect the molbloc to the molbox2 (see [molbox2 to molbloc Connections](#)).
2. Shut off the gas supply to the molbloc and open both molbloc ends to atmospheric (ambient) pressure.
3. Push **P&T** and observe the pressure measured by the upstream and downstream absolute RPTs (see [\[P&T\] \(Pressure and Temperature\)](#)). Observe the upstream and downstream pressures. These should indicate current atmospheric pressure and be in agreement within  $\pm 0.02$  % of the nominal full-scale calibrated range listed in [Reference Pressure Transducer \(RPT\) Specifications](#). If the two readings disagree by more than this, one or both RPTs can be out of calibration and service might be required.
4. Push **ESCAPE** to return to the main run screen.

#### Note

*The pressure measurements indicated in the P&T screen are corrected for TARE and AUTOZERO values. If the pressure readings disagree more than the values indicated above, refer to the manual sections regarding these functions before you consider calibration or service.*

## Check Proper Temperature Measurement Operation

To check that the temperature measurement operates properly:

1. Connect a molbloc to the molbox2 (see [molbox2 to molbloc Connections](#)).
2. From the molbox2 main screen, push **P&T** twice to arrive at the temperature screen. Observe the temperature readings of the two molbloc PRTs (see [\[P&T\] \(Pressure and Temperature\)](#)).
3. If the molbloc has been in a stable temperature environment for 30 minutes to 60 minutes, the temperature indications should be roughly ambient temperature and the two indications should agree within  $\pm 0.2$  °C. If the two readings disagree by more than  $\pm 0.2$  °C, there might be a problem with the molbloc or the molbox2 TEMPERATURE MEASUREMENT function and service might be required.

## Check the MFC Control Function (Optional)

With the keypad, show select MFC profile #1 for a voltage MFC or #2 for a current MFC (see [\[MFC\] \(Optional\)](#)). Push  to select MFC setpoints and observe the MFC screens, check that the MFC control operation is normal. If operation appears incorrect, check the MFC cable configuration and connection. Check the recommendations in [Additional Precautions to Take Before Making Flow Measurements](#), and the Troubleshooting Guide in [Troubleshooting](#) prior to contacting a Fluke Calibration authorized service Provider.

## Leak Check

Fluke Calibration recommends leak checking a new Product at start-up to make sure that no internal leaks developed during shipping and handling. See [<3Leak Check>](#).

## Check/Set Security Level

molbox2 has a security system based on user levels. By default, the security system is set to *low*, which includes certain access restrictions, and there is no password required to change the security level. See [<2level>](#) for information on the security level system. As part of the startup, set your security level and a password.

### **Caution**

**molbox2 comes with the security level set to *low* to avoid inadvertent altering of critical internal settings but with access to changing security levels unrestricted. Fluke Calibration recommends that at least the low-security level be maintained at all times and password protection be implemented.**

## Additional Precautions to Take Before Making Flow Measurements

Before you use the molbox2 to make meaningful flow measurements, consider:

- The pressure measuring RPTs must be tared at the operating line pressure (see [<1tare>](#)).
- Operating pressure and flow range should be within the limits of the molbloc calibration type and molbloc size for the flowing gas (see [Flow Measurement Specifications](#)).

- Make sure that the gas pressure connected to the molbloc is not great enough to overpressure the molbox2 internal RPTs.
- The gas type selected should be the gas flowing through the molbloc (see [\[GAS\]](#)).
- For flow measurement uncertainty within molbox2 specifications, the gas type should be a gas with which the molbloc is calibrated (see molbloc Calibration Report) or push **SETUP**, **<1molbloc>**,  to see if the gas is included in the molbloc calibration gas list (see [<1molbloc>](#)).
- Make sure the flow unit of measure used is correct. The default flow units of sccm and slm for any molbox2 are referenced to 0 °C and 101.325 kPa per SEMI E12-96. Many different types of flow units of measure are commonly used and have similar names. Before you select a unit of measure, familiarize yourself with [\[UNIT\]](#) and its subsections thoroughly.
- Do not supply a gas or connect a DUT upstream of the molbloc that may contaminate the molbloc. The filter assembly inside a molbloc-L works with a clean gas supply with limited contaminants. Consider this filter assembly a last line of defense against contamination and additional filtration can always be considered.
- Troubleshooting: For information on typically encountered start-up and operational issues, see [Troubleshooting](#).

## Short Term Storage

For short-term storage of molbox2, Fluke Calibration recommends:

- Vent the molbox2 pressure ports.
- Turn off the power.

## Operation

### General Operating Principles

#### molbloc Channel A and Channel B

molbox2 supports two molbloc input channels. The main purpose of this capability is to switch between two molblocs without making and breaking connections, for example, to switch between two ranges. It also allows two molblocs to be used simultaneously (see [<4A\\_B>](#)).

The active channel is indicated by the lit LED under the display. To change the active channel, push the **A/B** direct function key (see [\[A/B\]](#)). When a molbloc channel is activated, molbox2 operates internal valves to connect the molbloc pressure ports for that channel to the molbox2 pressure transducers. The temperature of the molbloc connected to the active channel is measured and the flow calibration data for the molbloc most recently activated on that channel is used to calculate flow.

**Figure 2. molbox2 Internal Pneumatic Schematic - CHANNEL A ACTIVE, molbloc-L OPERATION**

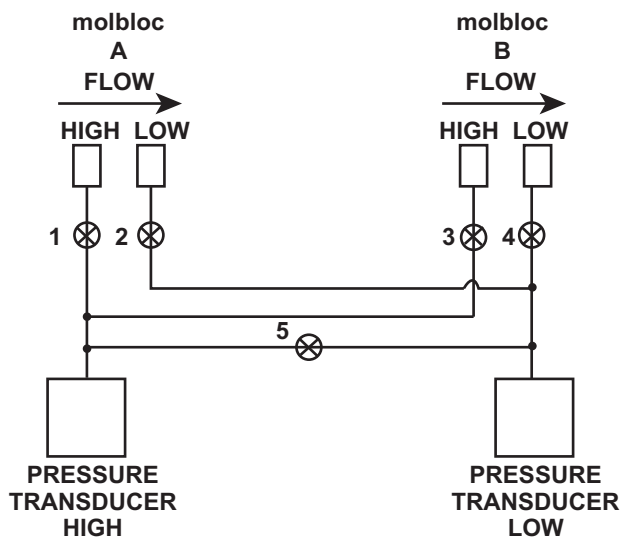

1. Channel A High Isolation: Open
2. Channel A Low Isolation: Open
3. Channel B High Isolation: Closed
4. Channel B Low Isolation: Closed
5. Bypass: Closed, molbox2+-S does not use this valve or connection.

User-selected settings such as gas, units, and K factor are all common between channels A and B. When one of these settings is changed while channel A is active, that setting will also be made for channel B, even if different molbloc types are connected to the two channels. The only setting that is not common to both molbloc channels is the tare value (see [\[TARE\]](#)).

### molbloc-L and molbloc-S Operation

molbox2 operates differently depending on whether a molbloc-L or molbloc-S is connected to the active channel. molbloc-L and molbloc-S operation use different displays and flow calculations and some menu items are present for only one type of molbloc.

Most molbox2 settings, such as gas, units, and K factor are common to both molbloc-L and molbloc-S operation. Changes made to these settings during operation of one type of molbloc will be in effect when the other type of molbloc is connected. The only setting that exists for both molbloc types, but is stored independently for each type, is the tare value. See [<1tare>](#) for details on the tare function.

Several of the molbox2 screens and functions described in this section are different for molbloc-L and molbloc-S operation. Where the differences are major, the description of these functions is divided into two parts.

## Flow Ready/Not Ready Indication

The character to the left of the measured flow on the run screen provides a flow *Ready/Not Ready* indication. This indication provides a clear and objective indication of when a stable flow has been achieved.

*Ready* <\*> is indicated when the current stability (rate of change) of flow is less than the stability limit. Set the stability limit (see <2stab>). The *Ready/Not Ready* indication is often used when comparing the molbox2 and a test device to help determine when steady state flow conditions are present so that a valid comparison reading can be made.

In addition to the conditions listed in *molbloc-L Operation* and *molbloc-S Operation*, molblocs that have named calibration support will flash the flow display and indicate a *Not Ready* condition when the measured flow exceeds the calibrated flow range by 5 % or the measured upstream pressure exceeds the calibrated pressure range by 10 kPa above the maximum pressure or 10 kPa below the minimum pressure. The downstream pressure is used when a molbloc-L downstream calibration is active.

### molbloc-L Operation

In molbloc-L operation, the *Ready/Not Ready* indication also helps guard against using molblocs above their valid range by monitoring the Reynolds number of the flow. If the Reynolds number of the current flow exceeds 1 300, the *Ready* (<\*>) indicator flashes. View the current Reynolds number with **P&T** (see [*P&T*] (*Pressure and Temperature*)). If molblocs are used within the pressure and flow range limits for the flowing gas and the pressure dependent calibration type (see *Flow Measurement Specifications*), a Reynolds number of 1 200 will never be exceeded (1 300 is used as the warning limit to allow for individual molbloc differences).

#### Note

*For molbloc-L 3E4 to reach 50 slm in N2 and Air the Reynolds limit allowed is 1550.*

*Ready/Not Ready* character indications are:

- <\*> Flow Ready (stable).
- <\*> (Flashing): Reynolds number > 1 (1550 for 3E4-L).
- <↓> Flow Not Ready (unstable and decreasing).
- <↑> Flow Not Ready (unstable and increasing).
- <P> Flow Not Ready, flow flashes (pressure exceeds calibrated pressure range by 10kPa)
- <F> Flow Not Ready, flow flashes (flow exceeds calibrated max flow by 5%)

### molbloc-S Operation

In molbloc-S operation, the *Ready/Not Ready* indication also warns the user when the BPR (back pressure ratio) is too high to ensure critical flow (see *molbloc-S BPR Limits*). When the BPR is beyond the choking limit, molbloc-S flow measurements may not be valid and the *Ready* indicator becomes <P>. The *Ready/Not Ready* indicators based on flow stability are also used in molbloc-S operation, but the <P> indicator takes priority over other indicators.

*Ready/Not Ready* character indications are:

- <\*> Flow Ready (stable).
- <↓> Flow Not Ready (unstable and decreasing).
- <↑> Flow Not Ready (unstable and increasing).
- <P> Flow Not Ready (BPR high / sub-critical flow)
- <P> [Alternate] Flow Not Ready, flow flashes (pressure exceeds calibrated pressure range by 10 kPa)
- <F> Flow Not Ready, flow flashes (flow exceeds calibrated max flow by 5 %)

### **Reference Pressure Transducer (RPT) Overpressure**

molbox2 has two absolute RPTs, one measures molbloc upstream pressure, the other measures molbloc downstream pressure and may provide a second measurement of molbloc upstream pressure in molbloc-S operation. In normal operation, they are not used at pressures greater than these maximum working pressures:

- molbox2 A350K:** 300 kPa absolute (44 psia)
- molbox2 A700K:** 600 kPa absolute (87 psia)
- molbox2-S A1.4M:** 1400 kPa absolute (203 psia)
- molbox2-S A2M:** 2000 kPa absolute (290 psia)

Exposing the molbox2 RPTs to pressures greater than the maximum operating pressure may damage them. molbox2 has a system of warnings and alarms to protect itself from overpressure (see [Upper Limit Alarm and Sequence](#)).

### **molbloc-S BPR Limits**

To make flow measurements within predictable measurement uncertainty limits with a molbloc-S flow element, critical (sonic) flow conditions must be present. Critical flow exists when the gas velocity reaches the local speed of sound at the throat of the molbloc-S Venturi nozzle.

molbox2 uses the back pressure ratio, or BPR (the ratio of the molbloc-S downstream absolute pressure to the upstream absolute pressure) to determine whether the flow is critical. For Venturi nozzles in general, the BPR must remain below a certain value for critical flow to exist. Commonly accepted practice for critical flow orifice use suggests that this limiting BPR value, or *choking ratio*, is approximately 0.5. That is, the absolute pressure downstream of the nozzle must be less than one half of the absolute pressure upstream of the nozzle. Empirical study of the Venturi nozzles used in molbloc-S shows that the actual choking ratio, or maximum BPR for critical flow, varies between about 0.4 and 0.9 as a function of the Reynolds number (Re) over which the molblocs are used. molbox2 continually calculates Re during flow measurement and can monitor the BPR to ensure that it does not exceed the choking ratio at the current Re conditions. molbox2 uses a conservative BPR limit to indicate to the user when the BPR approaches the choking ratio, to ensure that flow measurements are only made under *safe* critical flow conditions. molbox2 includes features to measure BPR, automatically alert the operator when the BPR is too high, and prevent measurements when flow is not critical (see [molbloc-L Operation, <5BPR> \(molbloc-S Operation Only\), <9BPR>](#)).

Maintaining a sufficiently low BPR must be considered by molbloc-S users when a user selects molbloc-S sizes and hardware setups to use for flow measurements. For example, if a molbloc-S is used with atmospheric pressure downstream, then the molbloc can only be used over a range of upstream pressures that start at the maximum pressure for its calibration type down to a minimum pressure value at which the BPR becomes equal to the BPR limit calculated by molbox2. Since mass flow through molbloc-S is proportional to the upstream absolute pressure, the flow range for the molbloc in this application is defined by the BPR limit also. To maximize the range of a molbloc-S element, connect a vacuum pump downstream to reduce the downstream pressure while flowing. When the downstream pressure is kept sufficiently low, the upstream pressure, and thus the mass flow rate, can be adjusted all the way down to the minimum value for the molbloc pressure dependent calibration type without being limited by the BPR value.

Depending on the placement of the molbloc-S in relation to the DUT and other hardware, and the availability and capacity of a vacuum pump that may be used, the molbloc-S downstream pressure varies in different applications. Calculating Re for different molbloc-S sizes and flow rates, and estimating the choking ratio (maximum BPR limit) as a function of Re is somewhat complex. [Table 14](#) is an example of the minimum flow that can be achieved with each molbloc-S size in nitrogen, without exceeding molbox2 BPR limits, when the molbloc-S downstream pressure is known. In actual operation, molbox2 calculates the Re and BPR ratio and can automatically provide an indication of whether the BPR is adequate for measurements to be made. For an estimate of the minimum critical flow at various downstream pressures in gases other than N<sub>2</sub>, contact your Fluke Calibration representative.

**Table 14. Minimum molbloc-S Critical Flow (slm) in Nitrogen at Various molbloc-S Downstream Pressures**

molbloc-S Designator	N2 Minimum molbloc-S Critical Flow [SLM @ 0°C] With molbloc Downstream Pressure Of: <sup>[1]</sup>										
	≤5 kPa (0.7 psia)	10 kPa (1.5 psia)	25 kPa (3.5 psia)	50 kPa (7 psia)	100 kPa (15 psia)	110 kPa (16 psia)	125 kPa (18 psia)	150 kPa (22 psia)	200 kPa (30 psia)	250 kPa (36 psia)	300 kPa (44 psia)
1E1-S	0.2 <sup>[2]</sup>	0.4	0.9	1.1	1.8	2.0	2.2	2.4	2.8	3.5	4.2
2E1-S	0.4 <sup>[2]</sup>	0.7	1.6	1.8	3.2	3.5	3.7	4.2	5.6	7.0	7.6
5E1-S	1 <sup>[2]</sup>	1.7	3.4	4.7	7.7	8.4	9.4	11	14	17	20
1E2-S	2 <sup>[2]</sup>	3.4	5.9	8.4	15	16	18	21	27	33	38
2E2-S	4 <sup>[2]</sup>	5.9	9.8	16	28	31	34	40	51	63	74
5E2-S	10 <sup>[2]</sup>	12	20	37	67	72	80	95	122	149	179
1E3-S	20 <sup>[2]</sup>	20 <sup>[2]</sup>	39	69	129	139	154	184	239	294	349
2E3-S	40 <sup>[2]</sup>	40 <sup>[2]</sup>	73	131	248	268	298	358	468	578	687
5E3-S	100 <sup>[2]</sup>	100 <sup>[2]</sup>	173	317	596	646	746	871	1 145	1 420	1 694
1E4-S	200 <sup>[2]</sup>	200 <sup>[2]</sup>	347	615	1 173	1 273	1 442	1 741	2 240	2 789	3 338

[1] When volumetrically-based mass flow units with reference temperatures other than 0 °C are used, flow values will generally be higher. For example, the flow values for a given molbloc and upstream pressure are approximately 7 % higher when expressed in slm @ 20 °C. Flow values at a given pressure may vary by up to 2 % due to flowpath machining tolerances.  
 [2] Limited by 20 kPa minimum calibration pressure rather than back pressure ratio.

## Main Run Screen

The MAIN run screen is the home screen that shows on power up and from which other functions and menus are accessed. It is the top level of all menu structures.

The MAIN run screen indicates the current measured flow as well as a variety of additional information.

The MAIN run screen applies to the molbloc on the active molbloc channel indicated by the red LED below the display (A or B). The appearance of the MAIN run screen differs depending on whether the active molbloc is a molbloc-L or a molbloc-S.

## molbloc-L Operation

Some items in the molbloc-L MAIN run screen may change or flash at times, to indicate that certain limits are exceeded, as described in the text that accompanies [Figure 3](#):

**Figure 3. Main Screen**

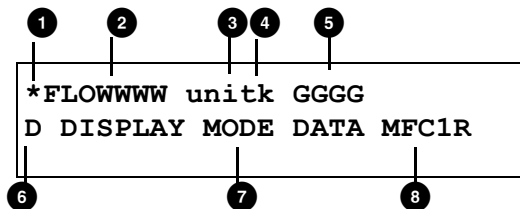

1. **<\*>** *Ready/Not Ready* indication; **<\*>** when *Ready* (flashes if Re number of the flow exceeds 1 300), **<↑>** (increase) or **<↓>** (decrease) this indicates the direction of flow rate evolution when *Not Ready* (see [Flow Ready/Not Ready Indication](#)).
2. **<FLOWWWW>**: Numerical value and sign of the flow measured by molbox2. Result of last flow averaging cycle if in AVERAGE display (see [<2Avg> \(Average\)](#)). Flashes if Re number of the flow exceeds 1 300. Flashes also occurs when a named calibration is active and the flow exceeds the calibrated range by 5 %, or the measured upstream pressure exceeds the calibrated pressure range by 10 kPa above the maximum pressure or 10 kPa below the minimum pressure. The downstream pressure is used when a molbloc-L downstream calibration is active. The field displays *PMODEL* when the pressure exceeds the molbox internal pressure model for the active calibration gas. See [Figure 3](#).
3. **<UNIT>** Current flow unit of measure (see [\[UNIT\]](#)). Flashes if BPR is higher than the choking limit.
4. **<k>**: Indicates whether a gas conversion factor or ADJ flow adjustment is applied to the displayed flow measurement. Possible indications include:
  - <k>**: Indicates that a gas correction factor (K factor) is currently applied to the measured flow (see [\[K\]](#)). **<K>** if a factor is applied, blank if no factor is applied.
  - <A>**: Indicates that a flow adjustment adder (and/or multiplier) is currently applied to the measured flow with the ADJ function (see [<3ADJ>](#)). **<A>** if ADJ is applied, blank if no ADJ is applied.

**Alternating** When both ADJ and a K factor are applied, the indication alternates between **<K>** and **<A>** at each screen update.
5. **<GGGG>**: Indicates the current molbox gas selection (see [\[GAS\]](#)). This should be the gas that flows through the molbloc. The field alternates with the named calibration name when a named calibration is active and more than one calibration is available for the selected gas.
6. **<D>**: Indication of what is displayed on the bottom line of the display as set by the DISPLAY function (see [\[DISPLAY\]](#)). Possible indications include:
  - <R>**: Current DISPLAY mode is RATE (see [<1Rate>](#)); or if **<n avg>** is in the bottom right hand corner of the display, current DISPLAY mode is *average* and this is the instantaneous reading AVERAGE screen (see [<2Avg> \(Average\)](#)).
  - <σ>** Current DISPLAY mode is AVERAGE (see [<2Avg> \(Average\)](#)).
  - <H>** Current DISPLAY mode is HI/LO (see [<3 Hi/Lo>](#)).
  - <Σ>** Current DISPLAY mode is TOTAL (see [<4Total> \(Totalizer\)](#)).
  - <=>** Current DISPLAY mode is UNIT (see [<5Unit>](#)).
  - <D>** Current DISPLAY mode is DEVIATION (see [<6Deviation>](#)).
  - <F>** Current DISPLAY mode is FREEZE (see [<7Freeze>](#)).
  - Blank, No character** Current DISPLAY mode is CLEAN (see [<8Clean>](#)).

7. **<DISPLAY MODE DATA>**: Information shown depends on current display mode (see [\[DISPLAY\]](#)).
8. **<MFC1R>**: If the molbox2 has the MFC control option, MFC profile and MFC switchbox channel number are displayed when MFC function is on. Followed by R if MFC is in regulation mode. This display is overridden by **<DISPLAY MODE DATA>** if the space is needed to display **<DISPLAY MODE DATA> (Average, Hi/Lo, Total, Unit, Deviation)**.

*Note*

*The MAIN run screen may be slightly different when MFC control is in use or an A\_B function is in use (see [\[MFC\] \(Optional\)](#) and [\[A/B\]](#)).*

*When a number is too large to show in the allocated display space, molbox2 shows <\*\*\*\*\*>.*

*molbox2 has a SCREEN SAVER function that dims the display if no key is pushed for 10 minutes. Push a key to restore full power to the display. You can change or suppress the screen saver. (see [<1ScrSVR>](#)).*

## **molbloc-S Operation**

As with molbloc-L there are limits on some of the conditions that may exist if the user expects to make accurate flow measurements with molbloc-S. The key condition that can be monitored is the back pressure ratio, or BPR, which determines whether critical flow through the molbloc is achieved (see [molbloc-S BPR Limits](#)).

When the BPR is in a *safe* region for critical flow measurements, the appearance of the MAIN run screen is identical to the MAIN run screen in molbloc-L operation (see [molbloc-L Operation](#)). When the molbox2 BPR limit is exceeded, there are two possible MAIN run screen indicators. A flashing flow value and unit indicate that the BPR limit has been exceeded. In this condition, the flow may not be critical and flow measurements should not be relied on to meet specifications. When the BPR limit is exceeded by a large margin, the flow is almost certainly not critical and the calculated value may be nonsensical, so the flow value is not shown and is replaced by **<BPR HI>**. In this state, the BPR value replaces the display field on the second line of the molbox2 terminal.

*Note*

*When molbloc-S is in the BPR OFF mode (see [<9BPR>](#)), BPR is not monitored and invalid flow values may be shown in the molbloc-S MAIN run screen with no indication that a the BPR value is high.*

1. **<\*>** Ready/Not Ready indication; **<\*>** when Ready **<↑>** (increase) or **<↓>** (decrease) indicates direction of flow rate evolution when *Not Ready*; **<P>** when BPR is higher than choking limit. (see [molbloc-S BPR Limits](#)).

2. **<FLOWWWW>**: Numerical value and sign of the flow measured by molbox2. Result of last flow averaging cycle if in AVERAGE display (see [<2Avg> \(Average\)](#)). Flashes if BPR is higher than the choking limit. If BPR exceeds the choking limit by a large margin, **<BPR HI>** replaces the flow value. The flow flashes when a named calibration is active and the flow exceeds the calibrated range by 5 % or the measured upstream pressure exceeds the calibrated pressure range by 10 kPa above the maximum pressure or 10 kPa below the minimum pressure. The field displays *PMODEL* when the pressure exceeds the molbox internal pressure model for the active calibration gas. See [Figure 3](#).
3. **<UNIT>** Current flow unit of measure (see [\[UNIT\]](#)). Flashes if BPR is higher than the choking limit.
4. **<k>**: Indication whether a gas conversion factor or ADJ flow adjustment is applied to the shown flow measurement. Possible indications include:
 

**<k>**: Indicates that a gas correction factor (*K factor*) is currently applied to the measured flow (see [\[K\]](#)). **<K>** if a factor is applied, blank if no factor is applied.

**<A>**: Indicates that a flow adjustment adder and/or multiplier) is currently applied to the measured flow with the ADJ function (see [<3ADJ>](#)). **<A>** if ADJ is applied, blank if no ADJ is applied. **Alternating** When both ADJ and a K factor are applied, the indication alternates between **<k>** and **<A>** at each screen update.
5. **<GGGG>**: Indicates the current molbox gas selection (see [\[GAS\]](#)). This should be the gas that flows through the molbloc. **<AirW>** indicates that air is selected and a humidity correction is applied (see [molbloc-S operation](#)). The field alternates with the named calibration name when a named calibration is active and more than one calibration is available for the selected gas.
6. **<D>**: Same as molbloc-L (see [molbloc-L Operation](#)).
7. **<DISPLAY MODE DATA>**: Information shown depends on current display mode (see [\[DISPLAY\]](#)).
8. **<MFC1R>**: Same as molbloc-L (see [molbloc-L Operation](#)).

*Note*

*The MAIN run screen may be slightly different when MFC control is in use or an A\_B function is in use (see [\[MFC\] \(Optional\)](#) and [\[A/B\]](#)).*

*When a number is too large to show in the allocated display space, molbox2 shows **<\*\*\*\*\*>**.*









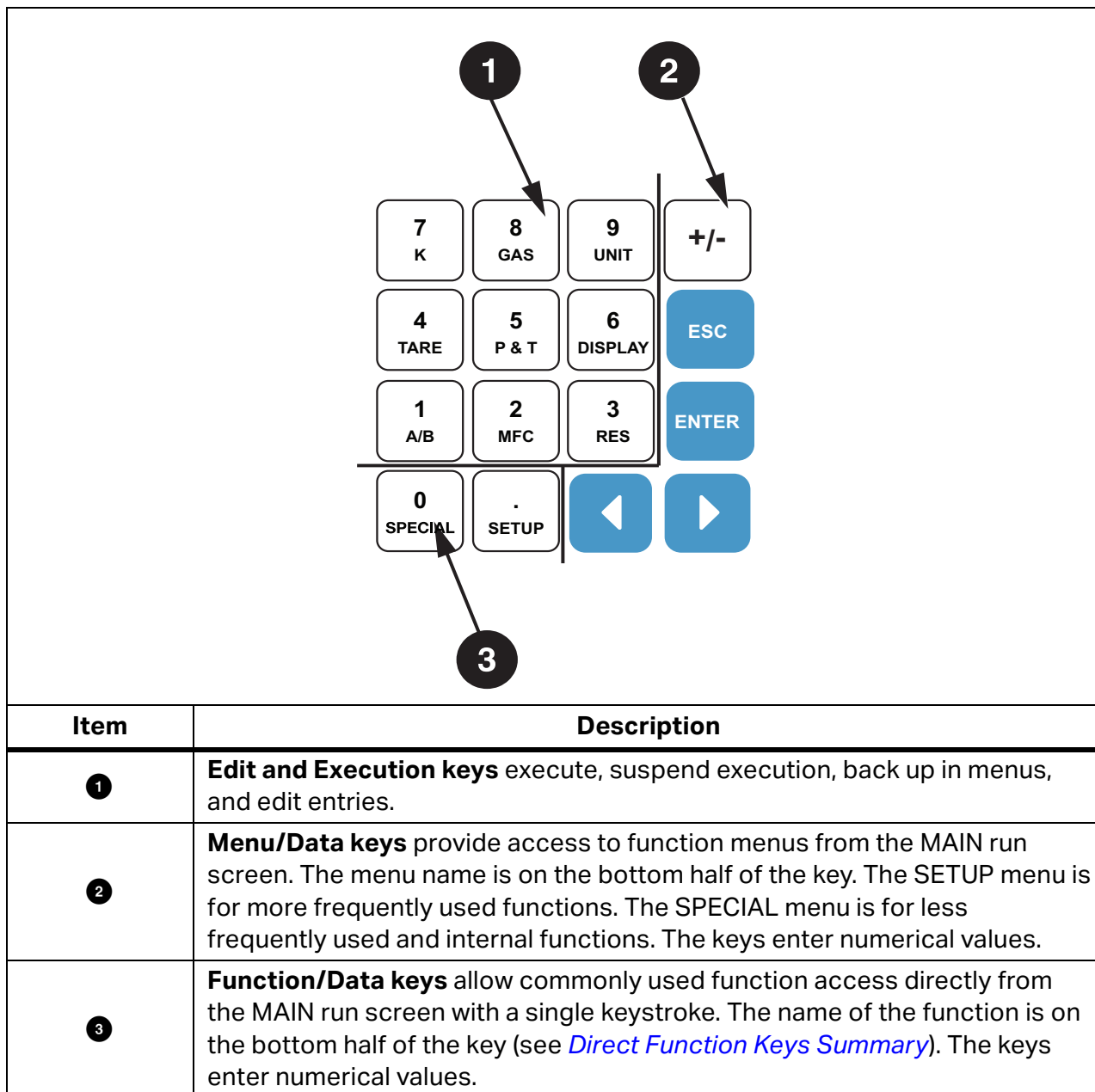

*molbox2 has a SCREEN SAVER function that causes the display to dim if NO key is pushed for 10 minutes. Push a key to restore full power to the display. The screen saver activation time can be changed or screen saving can be completely suppressed (see [<1ScrSVR>](#)).*

## Manual Operation

molbox2 offers the optimum balance between simple, intuitive operation, and the availability of a variety of functions with a high level of operator discretion. The operator interface is through the display and a multi-function keypad. Remote operation by RS232 or IEEE-488 interface is also available (see [Remote Operation](#)).

**Figure 4. Keypad**



- Push  to execute or move forward in the menu tree.
- Push  to move back in the menu tree and/or cause execution to cease or suspend without implemented changes. Push  repeatedly to eventually return to the MAIN run screen. From the MAIN run screen, push  for momentary viewing of the identification screen.
- Push  to change a numerical sign when you edit or to toggle through multiple screens when available.
- Push  and  to move the cursor forward or backward when editing a data entry. These keys also scroll through choices.
- Push the number of the selection directly to make menu selections or push  and  to place the cursor on the number of the selection, and then push .

*Note*

*Some screens go beyond the two lines provided by the display. This condition is indicated by a flashing arrow in the second line of the display. Push ← and → to move the cursor to access the lines that are NOT visible or directly enter the number of the hidden menu choice if known.*

## Direct Function Keys Summary



Local product operation is through the keypad. Direct function keys are active whenever the product is in its MAIN run screen. [Direct Function Key Operations](#) summarizes the operation of the direct function keys. See corresponding manual sections for full detail on each direct function.

*Note*









*Keep a copy of [Table 15](#) near the Product, especially when you first become acquainted with Product operation.*

Direct function keys ([Table 15](#)) are active from the main run screen. See corresponding manual sections for complete descriptions.

**Table 15. Direct Function Key Operations**

Key	Description
	Menu of commonly-used setup features that include MFC profiles, stability setting, and secondary unit changes.
	Menu of less-frequently used internal functions and settings that include preferences, resets, remote interfaces, and BPR (back pressure ratio) when using molbloc-S.
	Select active molbloc channel.

**Table 15. Direct Function Key Operations (cont.)**

<b>Key</b>	<b>Description</b>
	Turn on the MFC control option, select MFC profile to use, and MFC switchbox channel.
	Set the resolution with which the measured flow and other values are shown.
	Run the TARE, LEAK CHECK, PURGE, and AutoZ functions. The option to TARE is not available in a molbox2-S.
	Show the current pressure measurements (first push). Show the current molbloc temperature measurements (second push).
	Define the DISPLAY function for the second line of the molbox2 display. Choices include rate, average, hi/lo, totalize, 2nd unit, deviation, freeze, and clean.
	Set/change a device under test (DUT) gas correction factor (K factor).
	Set flow measurement gas. This key also accesses and select named gas calibrations on a molbloc.
	Set flow measurement unit. Choice of units can be customized.

## Direct Function Keys

### [K]

#### Purpose

 - Multiply the calculated flow value by the K factor. Generally used to apply the test device gas correction factor used when you calibrate a test device with a gas other than its normal gas.

#### Principle

Frequently, when you test or calibrate a flow-measuring device, it is not possible to flow the gas with which that device will normally be operated (the **process gas**). This may be because the **process gas** is toxic, corrosive, or because it is unavailable. When the **process gas** cannot be used for calibration, it is common to use a different gas to test or calibrate (the **calibration gas**). In this case, a factor that represents the relationship between the **calibration gas** and the **process gas** for the test device can be applied so that the **calibration gas** simulates the **process gas**. The **calibration gas** that simulates the **process gas** is often called a **surrogate gas** for the **process gas**.

The relationship between a test device **process gas** and **calibration gas** is frequently called a *K factor* or *gas conversion factor*. The factor value depends on specific properties of the test device and determining the value is the responsibility of the device manufacturer.

For example, Silane (SiH<sub>4</sub>) is a frequently used gas in semiconductor processing. SiH<sub>4</sub> is highly toxic and requires extensive handling precautions so it is not practical for use in calibration and testing. A major manufacturer of Mass Flow Controllers (MFCs) recommends that MFCs that are to be used with Silane be tested with Sulfur Hexafluoride (SF<sub>6</sub>), a non-toxic, non-flammable gas, using a conversion factor of 0.970.

In other words:

$$\text{SF6 flow} \times 0.970 = \text{equivalent SiH4 flow for the MFC}$$

Use the K function to enter a gas conversion factor. The flow values measured by the Product are multiplied by this conversion factor. In this example, enter **0.970** as **K** so that the values indicated by molbox2 when SF<sub>6</sub> is flowing through the molbloc simulate the flow of SiH<sub>4</sub> for that manufacturer's MFC.

When the K function is active, molbox2 does all of its flow calculations normally but multiplies the current flow value by the value of the K factor prior to showing it.

#### Note

*K factors or gas conversion factors are based on the properties of the DUT. K factors or gas conversion factors availability and validity are the responsibility of the device manufacturer. molbox/molbloc does not use factors or conversion coefficients between gases. Flow is calculated from molbloc characteristics and specific gas properties for each gas supported by molbox2. The gas selected on molbox2 (see [GAS]) which is shown in the upper right of the display should always be the gas that is actually flowing through the molbloc*

### Operation

To enable a gas conversion factor, push  from any run screen. The display shows:

**K Factor?**

1on 2off

If **<2off>** is selected, no conversion factor is applied. If **<1on>** is selected, the next screen is:

**K Factor:**

1.00000

Edit the gas conversion factor as necessary. Push  to return to the MAIN run screen with the entered *K factor* active. **The letter <K> is always appended to the flow unit indication in the run screens when the K function is ON (for example, sccmK).** A *K factor* value of 1 is handled as if the K function was OFF.

**⚠ Caution**

**When the K function is ON, as indicated by a <K> after the current flow unit in the first line of the MAIN run screen, the current flow indication is:**

**(flow as calculated by molbox2 for the selected gas) x (the current K factor)**

**Thus, the flow indicated is in error (biased) by the reciprocal of the K factor.**

**[GAS]**

 - To specify the gas that is currently flowing through the molbloc so that molbox2 uses the correct gas properties in its flow calculations.

**Principle**

molbox2 calculates the flow through a molbloc from:

- molbloc geometric characteristics
- gas pressures
- gas temperature
- specific characteristics of the flowing gas

The gas characteristics include:

- gas density under standard conditions
- change in gas density with pressure and temperature
- gas viscosity under standard conditions (when needed)
- changes in gas viscosity with pressure and temperature

Proprietary algorithms calculate gas density and viscosity (when needed) under the actual flowing pressure and temperature conditions from density and viscosity under standard conditions.

The characteristics of molbox2 supported gases and corresponding algorithms are stored in molbox2 memory. To correctly calculate the flow of a gas, you must use the correct information for that gas. The molbox2 GAS function allows the user to specify the flowing gas so that molbox2 uses the correct gas information to calculate the flow through the molbloc.

Properties for gases and gas mixtures available in the NIST RefProp10 database can be added to the molbox2. Contact your Fluke sales representative for details.

Selection of a gas using the GAS function also selects the molbloc (geometric) calibration data to be used for flow calculation. If a calibration has been stored in the molbloc for the selected gas, the molbloc calibration data for that gas is used. If a gas is selected that the molbloc is not calibrated for, the molbox2 uses the coefficients of the default gas, normally N2 for molbloc-L and Air for molbloc-S. If there are multiple N2 or Air calibrations on the molbloc, the coefficients for the calibration indicated as DEFAULT on the calibration report are used. When a calibration has not been performed on the molbloc in the gas selected using the GAS function, flow measurements have NO associated uncertainty or tolerance.

The operation of the GAS function, is different for molbloc-L and molbloc-S due to the support of humid air measurements with molbloc-S. They are described separately below.

### molbloc-L Operation

The molbox2 gases available for use with molbloc-L at the time of this manual creation are listed in [Table 16](#).

**Table 16. Available molbloc-L Gases**

<b>&lt;1inert&gt;</b>	<b>&lt;2flam1&gt;</b>	<b>&lt;3flam2&gt;</b>
<1N2> Nitrogen	<1H2> Hydrogen	<1iBtn> isoButane
<2He> Helium	<2O2> Oxygen	<2D2> Deuterium
<3Ar> Argon	<3CH4> Methane	<3NG> Natural Gas
<4Xe> Xenon	<4C2H4> Ethylene	
<5Ne> Neon	<5C3H6> Propylene	
<6Kr> Krypton	<6C3H8> Propane	
	<7C2H6> Ethane	
	<8butn> Butane	
	<9C2H2> Acetylene	
<b>&lt;4toxic&gt;</b>	<b>&lt;5fluor&gt;</b>	<b>&lt;6other&gt;</b>
<1CO> Carbon Monoxide	<1C2F6> Hexafluoroethane	<1Air> Air
	<2CF4> Carbon Tetrafluoride	<2N2O> Nitrous Oxide
	<3SF6> Sulfur Hexafluoride	<3CO2> Carbon Dioxide
	<4CHF3> Fluoroform	
	<5C4F8> Octofluorocyclobutane	

*Note*

<Butn> identifies Butane in molbox2 because the chemical symbol for Butane (C4H10) has more than the 4 characters used by molbox2 to abbreviate gas identifications.

Mixtures of known gases in known concentrations can be measured by calculation and use of the ADJ function (see <3ADJ>).

### OPERATION (molbloc-L Operation)

To specify the gas flowing through molbloc-L, push . The display shows:

Start page:

```
1inert 2flam1 3flam2
4toxic 5fluor 6other
```

Page down

```
4toxic 5fluor 6other
7cust
```

The gases available are grouped in categories to facilitate finding a specific gas and as a reminder when selecting a gas that may require special precautions in use. There is a list of gases under each category. For example, the **<1inert>** selection displays:

```
1N2 2He 3Ar
```

A secondary menu shows when a specifically calibrated gas is selected. The menu includes:

- the name of the gas
- calibration name
- the calibrated flow range
- the calibration type (PREM for premium or STD for standard)
- supported pressure range

If multiple calibrations are available for the selected gas arrow keys **<>** display after the pressure. Use the left right arrow keys to select the other calibrations.

```
He, HI 5.0 slm
STD 50-550 kPa <>
```

If the selected gas is not specifically calibrated on the molbloc a secondary menu shows that indicates that the default calibration for the molbloc is used to derive the flow of the selected gas. Push  to proceed.

```
No Air cal, N2 coef
used [ENTER]
```

Select the gas. Push  to return to the last run screen with the selected gas active. The selected gas is always shown in the upper right hand corner of the MAIN run screen.

*Note*

*The gas selected on the molbox2 should always be the gas that is flowing through the molbloc. molbloc/molbox does not use K factors or gas conversion factors between gases. When you calibrate or test a device with a surrogate gas, molbox2 should be set to the surrogate gas. The K factor or gas conversion factor, if used, defines the relationship between the surrogate gas and the process gas for the DUT not for molbox2 (see [\[K\]](#)). The K factor is supplied by the manufacturer of the DUT.*

### molbloc-S Operation

In addition to dry air, molbox2 supports measurement of ambient (humid) air flow with molbloc-S. When Air is selected as the molbloc-S test gas, the user is prompted to enter a value of the humidity ratio (also known as the absolute humidity or water ratio) of the ambient air. The humidity ratio, W, is defined as the ratio of water mass to gas mass in the flowing air. It is different from the relative humidity value, which is usually expressed as a percentage. Typical values of W are between zero and 0.06. molbox2 does not accept an entry for W greater than 0.1.

Typically, humidity measuring instruments report relative humidity, which is dependent on the ambient pressure and temperature. Users who do not have the W value available can use the Fluke Calibration free *Unit of Measure Converter* software utility or COMPASS for molbox or COMPASS for Flow calibration software to calculate W from measured pressure, temperature, and relative humidity. Visit [www.fluke.com](http://www.fluke.com), or see your Fluke Calibration sales representative for a copy of the *Unit of Measure Converter* software utility. Air relative humidity, pressure and temperature are converted to the humidity ratio, W, following Dalton's Rule and thermodynamic principals using water saturation properties:

$$W = .62188 \cdot \frac{P_g \cdot \left(\frac{RH}{100}\right)}{P_{amb} - P_g \cdot \left(\frac{RH}{100}\right)}$$

$P_g$  is the water saturation pressure, which can be calculated as:

$$P_g = C_0 T_{amb}^3 + C_1 T_{amb}^2 + C_2 T_{amb} + C^3$$

where:

$$C_0 = 0.0649289$$

$$C_1 = -53.0528$$

$$C_2 = 14509.9$$

$$C_3 = -1327760$$

If dry air is measured, then enter a W value of zero when prompted. Zero is the default W value.

When a non-zero W value is entered, molbox applies a correction to its air flow measurement for the change in air density due to humidity. If a correction for W is being applied to air flow measurements, a **<W>** is placed to the right of the **<Air>** gas indication in the MAIN run screen.

The humid air correction applied to the molbloc measured flow is (from ASME FEDSM98-5309):

$$q_m \text{ (ratio)} = a + bW + cW^2 + dW^3$$

where:

$$a = 1.0000$$

$$b = -0.336872$$

$$c = 0.158514$$

$$d = 0.131924$$

Note

*If an incorrect value of W is entered (for example, with any non-zero W value while flowing dry air), an error is introduced into the air flow measurement. W, humidity ratio, is different from relative humidity.*

### Operation (molbloc-S Operation)

To specify the gas flowing through molbloc-S, push . The display shows:

Start page:

```
1inert 2flam1 3flam2
4toxic 5fluor 6other
```

Page down

```
4toxic 5fluor 6other
7cust
```

The gases available are grouped in categories to facilitate finding a specific gas and as a reminder to when selecting a gas that may require special precautions in use. There is a list of gases under each category. For example, the **<4other>** selection displays:

```
1Air  2N2O  3SF6
4CO2
```

A secondary menu shows when a specifically-calibrated gas is selected. The menu includes:

- the name of the gas
- calibration name
- the calibrated flow range
- the calibration type (PREM for premium or STD for standard)
- the supported pressure range

If multiple calibrations are available for the selected gas, arrow keys **<>** show after the pressure. Use the left right arrow keys to select the other calibrations.

```
N2 , HI  5.0 slm
STD 50-550 kPa  <>
```

If the selected gas is not specifically calibrated on the molbloc, a secondary menu shows that indicates that the default calibration for the molbloc will be used to derive the flow of the selected gas. Push  to proceed.

```
No N2 cal, Air
coef used  [ENTER]
```

Select the gas. If **<1Air>** is selected, the display shows:

```
Humidity ratio:
0:1
```

Leave the value at zero when dry air is being flowed. Enter the appropriate non-zero value (see section immediately above) if humid air is being flowed.

Push  to return to the last run screen with the selected gas active. The selected gas is always shown in the upper right hand corner of the MAIN run screen.

#### Note

*The gas selected on the molbox2 should always be the gas that is flowing through the molbloc. molbloc/molbox does not use K factors or gas conversion factors between gases. When you calibrate or test a device with a surrogate gas, molbox2 should be set to the surrogate gas. The K factor or gas conversion factor, if used, defines the relationship between the surrogate gas and the process gas for the device being tested, not for molbox2 (see [\[K\]](#), Principle). The K factor is supplied by the manufacturer of the DUT.*

## [UNIT]

### Purpose



 - To specify the flow unit of measure in which molbox2 shows measured flow values.

### Principle

molbox2 calculates the mass flow of various gases in kilograms/second [kg/s]. molbox2 also supports conversions to a variety of other flow units of measure. The UNIT function allows you to select the flow unit of measure shown on the display. These include units of mass flow, including volumetrically based mass flow units (for example, sccm) as well as units of volume flow (for example, ccm). See [Table 17](#) for a complete list of the unit conversions available. molbox2 can also show the measured flow in two different units of measure simultaneously (see [<5Unit>](#)).

### Operation

If the molbox2 has the optional MFC control function (see [\[MFC\] \(Optional\)](#)), the unit of measure can be defined by the currently-selected MFC profile. In that case, use  to select the MFC output display unit (see [Units of Measure When Using the MFC Control Option](#)).

- If an MFC profile other than profile #1 or #2 is active, the unit of measure is the unit of measure selected in the MFC profile. If the MFC control function is not present, or is turned OFF, or MFC profile #1 or #2 is selected,  allows direct selection of molbox2 flow display units as described below.
- From the main run screen, push :

The display shows:

1sccm	2slm	3uccm
4pccm	5mg/s	6v1m

Select the necessary unit. For all units except **<uxxx>** or **<vlm>**, operation then returns to the run screen with the flow unit of measure changed to the selected unit. When user units (for example, uxxx) are selected, the reference temperature must be specified before the unit is activated (see [Volumetrically Based Mass Flow Units at Various Reference Temperatures \(UXXX\)](#)). When vlm (volume) units are selected, a menu of volume units is accessed. Select the volume unit and then specify the temperature and pressure of the flowing gas (see [Volume Flow Units \(vlm\)](#)).

#### Note

*If the MFC Control option is active and the MFC profile selected is NOT #1 or #2 (see [\[MFC\] \(Optional\)](#)), the molbox2 flow unit is automatically the unit specified in the current MFC profile (see [\[MFC\] \(Optional\)](#) and **<5MFC>**) and the UNIT function controls the unit used for displays of MFC set and measure values.*

*See [Flow](#) for specific molbox2 flow unit conversion calculations.*

*molbox2 supports many more flow units of measure than the six default units of the UNIT function. The six units available under the UNIT function can be customized to include any molbox2 supported units in any order (see **<8PRESU>**).*

#### Caution

**Many different types of flow units are commonly used including a wide variety of mass flow units as well as volume flow units. Please read [Mass Flow vs. Volume Flow](#) through [Volume Flow Units \(vlm\)](#) for additional information on the various unit definitions and how they are handled by molbox2 before making unit of measure selections.**

### Mass Flow vs. Volume Flow

#### Note

*COMPASS for molbox software users: conversions to volume (sometimes called actual) flow units are handled in COMPASS. When using COMPASS, the molbox always operates in mass flow units.*

molbox2 measures **mass flow** (quantity of material per quantity of time). molbox2 always calculates flow in terms of kg/second [kg/s]. It also supports conversions of kg/second to a variety of other flow units. These include other mass flow units such as g/s and mole/s as well as volumetrically based mass flow units (for example, sccm and slm) (see [Volumetrically Based Mass Flow Units at Various Reference Temperatures \(UXXX\)](#)). **In steady state flow, mass flow is the same at different points in the flow system independent of gas pressure and temperature.** Therefore, the measurement of mass flow made by the molbloc/molbox represents the mass flow at the same time at other points in a steady state flow system.

molbox2 can also make conversions to **volume flow** under specific pressure and temperature conditions by dividing the mass flow by the density of the gas under the specific pressure and temperature conditions (see [Volume Flow Units \(vlm\)](#)).

*Note*

*Volume flow is sometimes referred to as actual flow.*

**Volume flow depends on the actual temperature and pressure of the flowing gas at the point where volume flow is measured.** Generally, this point is not at the molbloc, it is at another point in the flow system (for example, at the DUT). At another point in the flow system, it is likely that the gas pressure and temperature are different from the gas pressure and temperature at the molbloc. Then, even in steady state flow conditions, the volume flow at the molbloc and the volume flow at another point in the system are likely to be different. Therefore, **to accurately predict volume flow at another point in the system, molbox2 must calculate volume flow based on the gas pressure and temperature at that other point, not at the molbloc.** For this reason, molbox2 requires that gas pressure and temperature conditions at the DUT be specified for volume flow measurements.

To estimate the flowing gas pressure and temperature at the point at which volume flow is to be measured may be difficult.

The relevant gas pressure when you measure volume flow is the absolute pressure of the gas. In cases in which the volume flow measurement is open to atmospheric (ambient) pressure, the volume flow pressure is atmospheric pressure. In other cases, there may be ways to estimate the pressure at the volume flow measurement point but it probably should be measured.

For temperature, if the volume flow measurement point is very near the molbloc, one possibility is to use the molbloc temperature measurement. By design, the molbloc causes the temperature of the gas that flows through the molbloc to take on the molbloc temperature. Therefore, the temperature of the gas as it exits the molbloc is the same as the molbloc temperature. If the volume flow measurement point is not immediately downstream of the molbloc, the best estimate of gas temperature is probably ambient temperature or the temperature of the device or bath used to stabilize gas temperature if one is present.

**⚠ Caution**

**Because volume flow (sometimes called actual flow) depends on gas pressure and temperature at the flow measurement point, gas pressure and temperature must be specified when you select volume flow units on molbox2. The measurement uncertainty (accuracy) in the volume flow measurement is highly dependent on the measurement uncertainty in the pressure and temperature specified. Typically, temperature errors have an effect on flow of about 0.35 %/°C and pressure errors have an effect on flow of about 1 %/kPa (6.8 %/psi) if the DUT is used near atmospheric pressure.**

## Volumetrically Based Mass Flow Units

molbox2 supports a number of volumetrically-based mass flow units of measure.

Volumetrically based **mass flow units** should not be confused with **volume or actual flow** units (see [Volume Flow Units \(vlm\)](#)). Volumetrically-based mass flow units define mass in terms of the quantity of gas that occupies a volume under standard conditions of pressure and temperature. Since there is no universally accepted definition of standard conditions, molbox2 supports the three most common variances.

- **Standard units (sxxx):** The *s* prefix indicates standard. Volumetrically based mass flow units preceded with the letter *s* (for example, sccm, slm, scfh) define standard conditions as pressure of 101.325 kPa absolute (14.6959 psia) and temperature of 0 °C (32 °F) and take into account the true compressibility of the flowed gas.
- **User units (uxxx):** The *u* prefix indicates user. This option provides support for volumetrically based mass flow units with a reference temperature other than 0 °C (see [Volumetrically Based Mass Flow Units at Various Reference Temperatures \(UXXX\)](#)). Volumetrically based mass flow units preceded with the letter *u* (for example, uccm, ulm) define standard conditions as pressure of 101.325 kPa (14.6959 psia) with the user specifying the reference temperature. User units take into account the true compressibility of the flowed gas.
- **Perfect units (pxxx):** The *p* prefix indicates perfect. This option provides support for volumetrically based mass flow units that assume ideal gas compressibility for all gases. Volumetrically based mass flow units preceded with the letter *p* (for example, pccm, plm) assume a gas compressibility factor of 1 for all gases and define standard conditions as pressure of 101.325 kPa (14.6959 psia) and temperature of 0 °C (32 °F).

### Note

*Volumetrically based mass flow units at reference temperatures other than 0 °C (32 °F) can be defined with user units (see [Volumetrically Based Mass Flow Units at Various Reference Temperatures \(UXXX\)](#)).*

*In early 1996, SEMI (a semiconductor industry interest group) adopted standard E12-96 which specifies that perfect units be used for volumetrically based mass flow units. To comply with the SEMI standard, pccm should be used rather than sccm. To purchase a copy of the relevant SEMI standard, contact SEMI at telephone 415.964.5111 or email [semihq@semi.org](mailto:semihq@semi.org).*

## Volumetrically Based Mass Flow Units at Various Reference Temperatures (UXXX)

Units that start with the letter *u* (user units) are volumetrically based mass flow units (see [Volumetrically Based Mass Flow Units](#)) for which a reference temperature other than 0 °C is desired.

When a user unit is selected, the reference temperature necessary must be specified. After a user unit is selected, the display shows:

```
Temperature ref?  
0°C
```

Enter the reference temperature necessary for the volumetrically based mass flow unit selected. To change the temperature units between °C and °F, push  and select **<9tempU>** (see [<9TEMPU>](#)). The temperature selected applies to all the user units.

*Note*

*Volumetrically based mass flow units, including user units (uxxx) and perfect units (pxxx), are discussed further in [Volumetrically Based Mass Flow Units](#).*

### Volume Flow Units (vlm)

*Note*

*See [Mass Flow vs. Volume Flow](#) before you use volume flow units. Volume flow is sometimes referred to as actual flow.*

To measure flow in volume flow units (sometimes referred to as *actual flow units*), push , **<vlm>** under the UNIT function. If **<vlm>** is unavailable, see [Customize FLOW Units Available Under The UNIT Function](#) This selection accesses the menu of volume units available.

Select the correct volume flow unit, the display shows:

```
①      ②  
P:100.325 kPa T:20.1°C  
Edit P&T? 1No 2Yes
```

- ① - Current volume flow pressure.
- ② - Current volume flow temperature. Indicates **<bloc>** if the current setting is to use the molbloc temperature.

To retain the current volume flow pressure and temperature, select **<1no>** and operation returns to the MAIN run screen with the selected volume flow unit active. To change the volume flow pressure and/or temperature select **<2yes>**.



The next screen gives the choice of having the volume flow gas temperature be either the molbloc temperature or a user specified temperature. If **<2user>** is selected, a screen to enter the temperature is presented before continuing. If **<1molbloc>** is selected, the volume flow temperature is automatically taken as the molbloc temperature.

```
Gas temperature:
1molbloc  2user
```

The next screen is to edit the volume flow pressure in the current pressure unit of measure. Push  to accept the edited value as the volume flow pressure and returns to the MAIN run screen with the selected volume flow unit and gas temperature and pressure active.

```
Volume unit gas pres
101.325 kPa
```

#### Note

The temperature and pressure units of measure used to specify volume flow conditions can be changed with , **<8presU>** for pressure (see **<8PRESU>**) and , **<9tempU>** for temperature (see **<9TEMPU>**).

#### Caution

**Because volume flow depends on gas pressure and temperature at the flow measurement point, gas pressure and temperature must be specified when you volume flow units. The measurement uncertainty in the volume flow measurement is highly dependent on the measurement uncertainty in the pressure and temperature specified (see [Mass Flow vs. Volume Flow](#)).**

#### Customize FLOW Units Available Under The UNIT Function

The UNIT function provides a choice of different flow units of measure. The units that are available by default are the six indicated in [\[UNIT\]](#). However, molbox2 supports many other units. These other units can be made available for selection by customizing the UNIT function.

To customize the UNIT function:

1. Push .

2. Select **<7flowU>**.

The display shows:

**Set up user unit #1**

**<#1>** corresponds to the first of the available selections under the UNIT function. Enter the number of the selection that you would like to change.

The display becomes:

**Flow unit type: 1std**  
**2user 3perfect 4vlm**

3. Select the flow unit type of the necessary flow unit (see [Table 17](#)).

4. Select the necessary unit.

**Table 17. Available Flow Units**

<b>&lt;1std&gt;</b>	<b>&lt;2user&gt;</b>	<b>&lt;3perfect&gt;</b>	<b>&lt;4vlm&gt;</b>
<1mol/s>	<1ulm>	<1plm>	<1ccm>
<2kg/s>	<2uccm>	<2pccm>	<2lm>
<3mg/s>	<3ucfm>	<3pcfm>	<3lh>
<4slm>	<4ucfh>	<4pcfh>	<4m3h>
<5sccm>	<5um3h>	<5plh>	<6cfm>
<6scfm>		<6pm3h>	<7cfh>
<7scfh>			
<8slh>			
<9sm3h>			

### Note

The <4vlm> unit selection embeds the selection vlm into the UNIT function rather than a specific volume unit. The vlm selection provides access to all the volume flow units. In summary the unit types are:

<1std> (standard): mass flow units for which standard conditions are temperature of 0 °C, standard atmosphere and using the true compressibility factor of the gas.

<2user>: mass flow units for which standard conditions are a user-settable temperature, standard atmosphere and using the true compressibility factor of the gas.

<3perfect>: mass flow units for which standard conditions are temperature of 0 °C, standard atmosphere and assuming a compressibility factor of 1 for all gases.

<4vlm>: volume flow units.

See Sections [Mass Flow vs. Volume Flow](#) through [Volume Flow Units \(vlm\)](#) for additional information on flow unit types

## [TARE]

### Purpose

 accesses these functions:

- **TARE function:** To zero the molbox2 differential pressure readings in molbloc-L operation or verify the two RPTs by comparing them against each other in molbloc-S mode (see [<1tare>](#)).
- **PURGE function:** To purge the molbloc connection lines and molbox2 internal volume of a first gas with a second gas by flowing the second gas through the molbox2 (see [<2Purge>](#)).
- **LEAK CHECK function:** To check the molbox2 internal pneumatic circuit and/or the external test circuit to which molbox2 is connected, for leaks (see [<3Leak Check>](#)).
- **AUTOZ function:** To periodically offset the molbox2 RPTs relative to a reference pressure value in order to compensate for possible changes in the RPT zero between full recalibrations (see [<4AutoZ>](#)).
- **BPR function (present only in molbloc-S operation):** To measure and show the molbloc-S back pressure ratio (BPR) while operating in a BPR mode which does not continuously read and show BPR (see [<5BPR>](#) ([molbloc-S Operation Only](#))).

### Operation

Push  to access the available functions. Select the necessary function.

```
1tare 2purge
3leak check 4AutoZ ↓
5BPR
```

*Note*

*Some screens (for example, the Tare menu) may go beyond the two lines provided by the display. This is indicated by a flashing arrow in the second line of the display. Push the ◀ and ▶ keys to move the cursor to access the lines that are NOT visible or directly enter the number of the hidden menu choice if known.*

<1tare>

The purpose and operation of the tare function is different for molbloc-L and molbloc-S operation. It is described separately below for the two modes. The molbox2-S does not support the ability to tare as it does not support laminar molbloccs.

### molbloc-L Operation

#### **Purpose**

To zero the molbox2 at the molbloc operating pressure. Zeros the differential reading between the two reference pressure transducers.

#### **Principle**

Consider the molbox2 TARE function as the equivalent of the zeroing function performed on many instruments prior to making measurements.

molbox2 calculates the flow through a molbloc-L from the differential pressure across the molbloc. The differential pressure across the molbloc is measured by taking the difference in the absolute pressure measured by the two molbox2 internal RPTs. One RPT is connected to the upstream molbloc pressure port and the other to the downstream molbloc pressure port.

If a common pressure is applied to both RPTs, the differential pressure indicated should be zero. If a differential pressure value is observed, the value indicated represents an offset in the differential measurement which appears as an offset or *zero error* on the flow through molbloc-L calculated by the molbox2. The TARE function allows the differential indication between the two RPTs to be zeroed at the molbloc operating pressure to eliminate the zero error in differential pressure measurement.

When the TARE function is activated, the molbox2 internal valves operate to pneumatically connect together the two absolute transducers at the molbloc operating pressure (see [Figure 5](#)). Select whether this pressure is the upstream or downstream molbloc pressure so that the tare can be made at the pressure that will be held stable during operation (generally by a regulator or because it is open to atmosphere). Activating the tare causes molbox2 to record the current differential as the *tare value*. The tare value is then used to correct all subsequent RPT readings. The *tare value* is the difference between the two transducer readings ( $hi - lo$ ). After taring, the upstream RPT is corrected by  $(- \text{tare value}/2)$  and the downstream RPT is corrected by  $(+ \text{tare value}/2)$ .

**Figure 5. molbox2 Internal Pneumatic Schematic - Taring CHANNEL A, Upstream molbloc-L Operation**

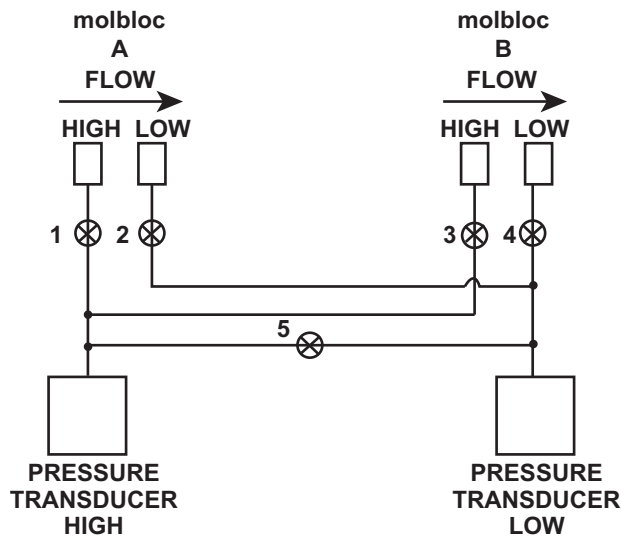

1. Channel A High Isolation: Open
2. Channel A Low Isolation: Closed
3. Channel B High Isolation: Closed
4. Channel B Low Isolation: Closed
5. Bypass: Open

## Operation

### Note

At a minimum, do the TARE function whenever the operating pressure of the molbloc is changed significantly, at the beginning of each test, or any time a significant zero error is observed. For best results, it is possible to tare before every reading since taring can be executed while flowing. Best results are obtained if the TARE function executes with a stable flow through the molbloc.

If the molbox2 is in A+B or A/B mode, specify the channel to tare before taring.

To access the TARE function:

1. Push , **<1tare>**.

The display shows:

```
Select tare pressure:
1upstream 2dnstream
```

2. Select **<1upstream>** to tare the molbox2 RPTs at the molbloc upstream pressure (see [Figure 4](#)).
3. Select **<2dnstream>** to tare the RPTs at the molbloc downstream pressure (Low isolation valve open, High isolation valve closed).

4. Select the position where the pressure remains the most constant during molbloc operation.

The next display is:

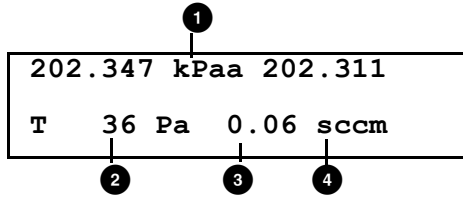

- 1 - The current pressure read by the upstream (left) and downstream (right) RPTs without taking into account the current *tare value*. These are *untared* readings in the current pressure units.
- 2 - <T>, flashing, to indicate that this is a TARE display showing the *tare* between the two absolute RPTs.
- 3 - The difference between the *untared* upstream and downstream absolute pressure readings (upstream - downstream). This differential value is always in Pascal [Pa].
- 4 - The flow that corresponds to the current *untared* differential pressure in the current flow units.

This display allows the current *untared* absolute pressures and the resulting *untared* differential pressure from the difference of the two absolute RPTs to be observed. The flow value represents the current *untared* zero error in terms of flow. It does not necessarily represent the current zero error on flow measurements as a *tare* value other than zero is probably already active.

5. Push when ready. molbox2 makes measurements to determine a new tare value.

The next display shows:

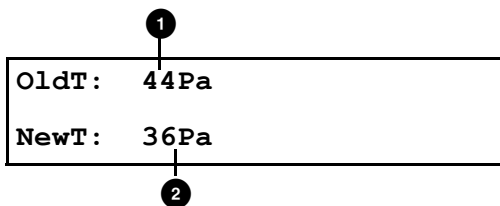

- 1 - The *tare value* currently in use [Pa].
  - 2 - The new *tare value*, that results from this execution of the TARE function [Pa].
6. Push to activate the new *tare* and return to the MAIN run screen
  7. Push to return to the display without activating the new *tare*, leaving the old *tare* active.





### Note

The tare screen shows the upstream and downstream RPT readings *WITHOUT* the current tare applied. The  screen shows the RPT readings *WITH* the tare applied (see [\[P&T\] \(Pressure and Temperature\)](#)).

## Limits and Errors

Excessively large *tare* values can diagnose molbox2 RPT malfunction, the need to recalibrate or possible poor execution of the TARE function. To protect against improper *taring* and to alert to possible RPT malfunction, molbox2 checks the *tare value* before it is activated and shows warnings when appropriate. In the most extreme case, molbox2 will not allow the *tare value* to be activated. The limits checked and their consequences are as follows:

**RPT coherence test:** When attempting to activate a new tare, molbox2 checks the coherence between the two transducers and alerts the operator to excessive disagreements. The test has two levels.

- If the new *tare* is  $200 \text{ Pa} < \text{tare} < 3,000 \text{ Pa}$ , a caution message shows. Push  to override the caution and activate the new *tare*. Push  to return to the TARE screen.
- If the new *tare* is  $> 3,000 \text{ Pa}$ , the new *tare* cannot be activated. Push  or  to return to the *tare* screen and retain the old **tare**. It is likely that molbox2 needs service or a grossly incorrect adjustment has been made to one or both of the RPTs.

### Note

*If a caution message shows or a tare cannot be activated during the taring process, repeat the taring process. If the caution persists, verify the calibration of the RPT(s) (see [Calibration Of Reference Pressure Transducers \(RPTS\)](#)). If the tare still cannot be activated, recalibrate the RPT(s) and molbox2 may require other service.*

## molbloc-S operation

### Purpose

To check the molbox2 RPT absolute pressure readings by comparing them at a common molbloc-S upstream absolute pressure. Note that the taring function is not supported by molbox2-S.

### Principle

When you measure the flow through molbloc-S, the critical pressure measured by molbox2 is the molbloc upstream pressure. The downstream pressure is only monitored to be sure that critical flow conditions exist (see [molbloc-S BPR Limits](#)). To reduce the uncertainty on the upstream pressure measurement, molbox2 employs internal valving to direct the upstream pressure to both RPTs, and the average of the two readings is used as the measured molbloc upstream pressure. To take advantage of this RPT averaging, the molbox2 must be in either BPR OFF or Auto BPR mode (see [<9BPR>](#)).

molbox2 dynamically tares the two RPT readings when they are connected together, so the user can view the *live* average pressure that is calculated and to allow smooth pressure and flow measurements during valve transitions in the Auto BPR mode (see <9BPR>). RPT taring in molbloc-S operation occurs automatically when needed and does not need to be initiated or performed by the user.

The molbloc-S TARE function verifies that the two RPT measurements agree within an acceptable tolerance when a common pressure is applied to them. When the TARE function is selected, the molbox2 internal valves operate to connect both Q-RPTs the active channel UPSTREAM pressure port (see Figure 6). The RPT readings and the difference between the two RPT readings (tare value) shows. A message indicates whether the tare value is acceptable, or indicates a need for pressure verification or calibration of the RPTs. There is no need to save a new tare value in molbloc-S operation.

As in molbloc-L operation, the molbloc-S tare value is the difference between the two transducer readings (hi - lo). In BPR modes where the tare value is dynamically calculated and applied, the upstream RPT is corrected by  $(- \text{tare value}/2)$  and the downstream RPT is corrected by  $(+ \text{tare value}/2)$ . See Figure 6.

**Figure 6. molbox2 Internal Pneumatic Schematic- Taring Channel A, molbloc-S Operation**

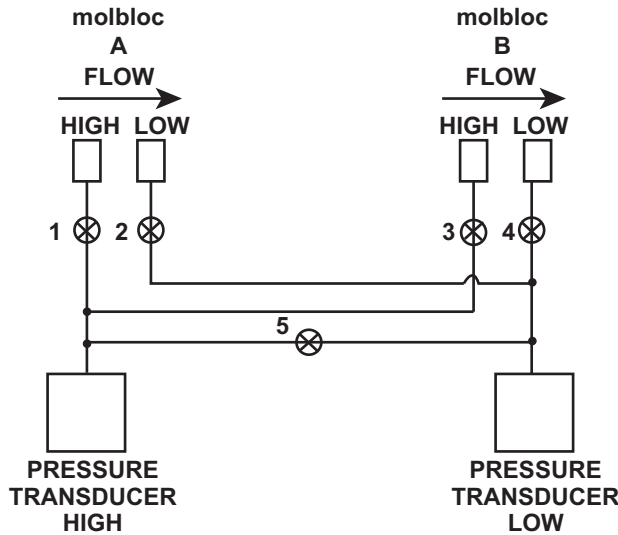

1. Channel A High Isolation: Open
2. Channel A Low Isolation: Closed
3. Channel B High Isolation: Closed
4. Channel B Low Isolation: Closed
5. Bypass: Open

**Operation**

To access the TARE function:

1. Push , <b1tare>.

The display shows:

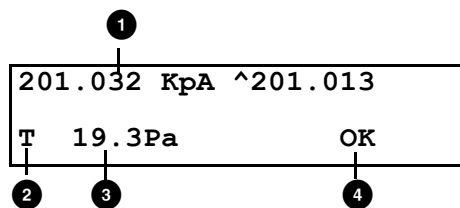

- ① - The current pressure read by the upstream (left) and downstream (right) RPTs without taking into account the current tare value. These are *untared* readings in the current pressure units.
- ② - **<T>**, to indicate that this is a TARE display and shows the tare between the two absolute RPTs.
- ③ - The difference between the *untared* upstream and downstream absolute pressure readings (upstream - downstream). This differential value is always in Pascal [Pa].
- ④ - Tare message

For molbox2 **A350K**:

- <OK>**                   if tare is less than 50 Pa
- <CHECK>**               if tare is between 50 and 200 Pa
- <NEED CAL>**          if tare is greater than 200 Pa

For molbox2 **A700K**:

- <OK>**                    If tare is less than 120 Pa,
- <CHECK>**               if tare is between 120 and, 500 Pa
- <NEED CAL>**          if tare is greater than, 500 Pa

*Note*

*The tare screen shows the upstream and downstream RPT readings WITHOUT the current tare applied. The  screen shows the RPT readings WITH the tare applied (see [\[P&T\] \(Pressure and Temperature\)](#)).*

## <2Purge>

### **Purpose**

To purge the lines between the molbloc and the molbox2 and the internal molbox2 volumes of one gas with another gas by setting up a molbox2 valving configuration in which gas flows through the molbox2. The purge function is not supported by molbox2-S.

### **Principle**

molbox2 supports the measurement of flow of a variety of gases. To calculate the flow, the thermodynamic characteristics of the gas must be known. These are stored in molbox2 memory. For the flow to be calculated correctly, the gas flowing through the molbloc must be the gas that is selected on the molbox2 (see [\[GAS\]](#)). When switching from the measurement of one gas to another, the old gas remaining in the circuit and the new gas being flowed may mix for some time so that the gas flowing through the molbloc is not purely the new gas. Erroneous measurements may result. For this reason, it is important to purge the lines upstream and downstream of the molbloc when changing gases. It is also important to purge the molbox2 itself which, since there is normally no flow through it, may trap and hold the old gas.

The PURGE function facilitates purging the molbox2. PURGE sets up the molbox2 internal valving so that flow can pass through the molbox2 (see Figure 7). In this configuration, the lines between the molbloc and molbox2 and the molbox2 internal volume can be purged by flowing the new gas in the normal flowing configuration. The flow resistance through the molbloc creates a differential pressure which causes flow through the molbox2 to occur, purging the molbox2 with the new gas.

**Figure 7. molbox2 Internal Pneumatic Schematic- Purging Channel A**

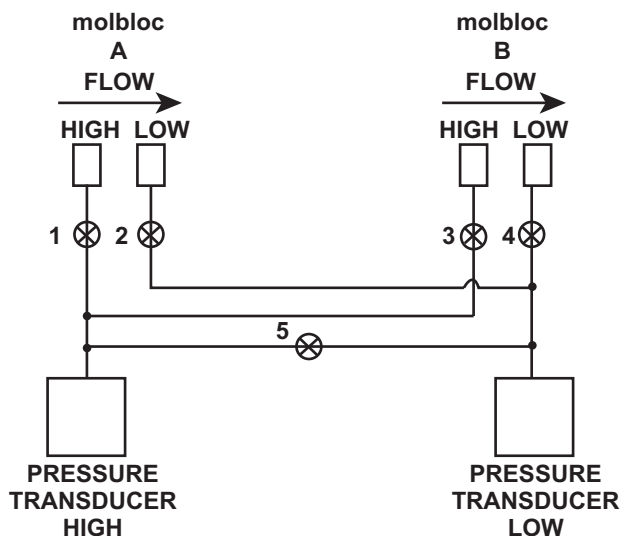

1. Channel A High Isolation: Open
2. Channel A Low Isolation: Open
3. Channel B High Isolation: Closed
4. Channel B Low Isolation: Closed
5. Bypass: Open

**Operation**

*Note*

*For best results, execute the PURGE function whenever the species of the gas flowing through the molbloc is changed. Prior to activating the PURGE function, set flow through the molbloc to the highest rate that is practical. Then, with the gas flowing, activate the PURGE function. Very small volumes of gas remain trapped (deadended) in the molbox2 in the PURGE configuration. Therefore, you may want to execute the PURGE function more than once to clear these volumes by the pressure changes caused by PURGE execution.*

To access the PURGE function push 4  
TARE, **<2purge>**. The display shows:

Set purge time:  
 15 sec

The purge time can be edited. Push  to cause molbox2 to set its internal valving to the purge configuration (see [Figure 7](#)) and go to the PURGE display:

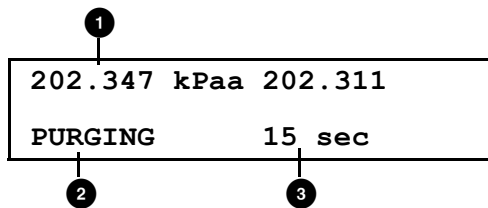

- ❶ - The current pressure read by the upstream (left) and downstream (right) RPTs in the current pressure unit of measure.
- ❷ - **<PURGING>** to indicate that this is a PURGE display.
- ❸ - Countdown of purge time remaining in seconds.

molbox2 remains in the purge condition until the purge time countdown elapses. It then automatically returns to normal operation. When the countdown elapses operation returns to the run screen from which PURGE was accessed.

To interrupt the PURGE function, push .

#### Note

*The appropriate purge time setting depends on the flow rate and the volumes upstream and downstream of the molbloc. Typically, 15 seconds to 30 seconds is adequate. The time needed increases as flow rates go down and volumes go up.*

#### **Caution**

**When you use the PURGE function, remember that the molbox2 absolute RPTs are exposed to the pressure. Do not apply pressure >600 kPa (87 psi).**

#### Note

*If the molbox2 is in A+B or A/B mode, the PURGE function executes for the specified purge time for channel A and then repeats the purge sequence for channel B.*

## <3Leak Check>

### Purpose

Accesses the LEAK CHECK and SYSTEM LEAK CHECK functions which use the pressure and flow measurement capabilities to check molbox2 and/or the system to which it is connected for leaks.

## Principle

molbox2 is used both as a tool to accurately measure unknown flow values and as a calibration standard to calibrate other devices by comparison. Leaks within the molbox2 pneumatic circuit can cause erroneous flow measurements. Leaks in the external flow circuit can cause the flow through the molbloc to be different from the flow at another point in the system so that, even with an accurate measurement and steady state flow, the molbox2 indication is not an accurate indication of flow at the other point in the system.

To obtain valid measurements, it is important that leaks in molbox2 and/or the external flow system be identified and eliminated to the extent possible. molbox2 uses its precision on-board pressure and flow measurement capabilities to help identify leaks with INTERNAL and EXTERNAL LEAK TESTING functions.

## Operation

1. Push  and select **<3leak check>** to access the LEAK CHECK functions.
2. Select **<1molbox>** or **<2system>**.

**<1molbox>** leak checks the internal molbox2 pneumatic circuit.

**<2system>** leak checks the system to which the molbloc/molbox is connected.

### Note

*If the molbox2 is in A+B or A/B mode, the molbloc channel (A or B) to leak check must be specified prior to running the leak check.*

## Leak Check molbox

### Purpose

To check the internal molbox2 pneumatic circuit for leaks.

### Principle

You do not need to run the MOLBOX LEAK CHECK frequently. MOLBOX LEAK CHECK is to troubleshoot when there appears to be a leak or other molbox2 measurement problem whose source cannot be identified by the SYSTEM LEAK CHECK or other troubleshooting means. Fluke Calibration recommends to run the MOLBOX LEAK CHECK after it has been shipped or if you suspect that the molbox has been exposed to a large shock or liquid or particulate contamination.

## Operation

1. Push .
2. Select **<3leak check>**, **<1molbox>**.

The next display shows:

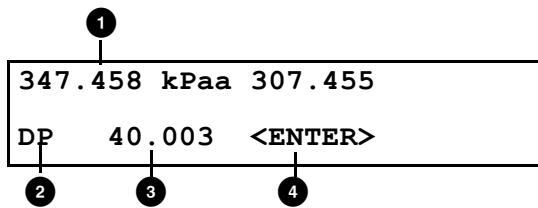

- ① - The pressure read by the upstream transducer (left), the downstream transducer (right) and the pressure unit of measure (middle).
- ② - Indicator that the figure that follows is differential pressure.
- ③ - Differential pressure across the molbloc in current pressure unit of measure.
- ④ - Prompt for the action to take when ready.

The molbox2 internal valving is in its normal measuring configuration (see [Table 11](#)). This display assists in setting the leak check pressure.

Apply the maximum differential pressure across the molbloc that is normally encountered during flow measurement while working at your typical absolute working pressure. Neither pressure should be less than atmosphere. Use the <DP> indication on the molbox2 display to set the absolute and differential pressure.

Once the pressure setting is correct, push . The molbox2 actuates its internal valves to isolate itself from the molbloc and trap the upstream and downstream pressures on its RPTs (see [Figure 7](#)).

The display shows:

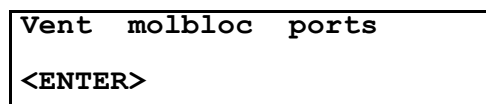

Assure that both molbox2 rear panel pressure connections are vented. Since the pressure quick connections on the molbox2 and the quick-connectors on the molbox2 pressure connection tubes seal when disconnected, they cannot be vented by disconnecting them. The easiest way to assure that the connections are vented is to maintain the normal connections to the molbloc, shut off the molbloc gas source and open one or both ends of the molbloc so it can vent to atmospheric pressure. Another alternative is to install the non-sealing quick connectors (P/N 3068652) provided in the molbox accessories (see [Inspect the Contents](#)) into the molbox2 quick connectors.

**Figure 8. molbox2 Internal Pneumatic Schematic - Leak Check molbox Channel A**

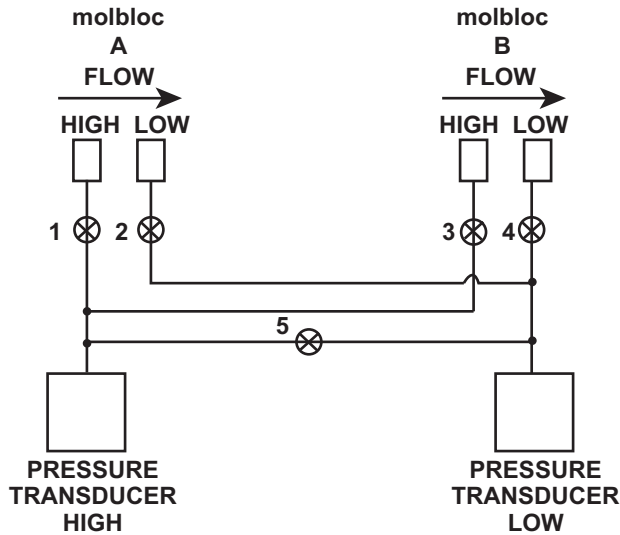

1. Channel A High Isolation: Closed
2. Channel A Low Isolation: Closed
3. Channel B High Isolation: Closed
4. Channel B Low Isolation: Closed
5. Bypass: Closed

Once the molbox2 pressure connections are vented, push **ENTER**.

The display shows:

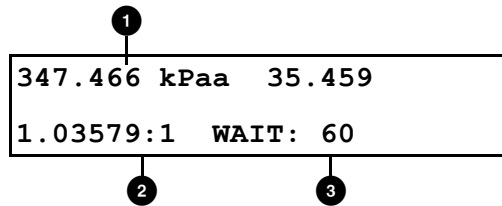

- 1 - The pressure read by the upstream RPT (left), the downstream RPT (right) and the pressure unit of measure (middle).
- 2 - The ratio of the upstream RPT reading to the downstream RPT reading.
- 3 - Leak check count down in seconds.

molbox2 counts down for 60 seconds while it monitors the ratio of the two pressures and then determines whether an internal leak was present. A significant leak in a pressure isolation valve or a bypass valve between the two channels will cause the ratio between the two pressures to vary.

The molbox2 LEAK CHECK function should end with the prompt:

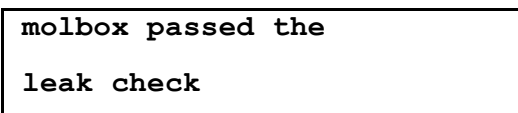

If any other prompt appears, repeat the process. If the leak check fails consistently, note the failure message and contact a Fluke Calibration authorized service provider (see the warranty at the start of this manual).

## Leak Check System

### Purpose

To leak check the external system that is connected to the molbox2.

### Principle

Fluke Calibration recommends to run the SYSTEM LEAK CHECK whenever critical physical connections in the system attached to the molbloc are broken and reconnected. Critical connections are ones that are between the molbloc and the DUT, which, if they leak, cause the flow through the molbloc and the DUT to differ. Whenever you connect a new DUT to the system, run the SYSTEM LEAK CHECK.

The SYSTEM LEAK CHECK monitors changes in pressure in a closed system defined by the user to help determine whether a leak exists in the system. One of the ways to detect a leak is to monitor pressure decay in the pressurized closed system. When the test volume is large, significant leaks can exist undetected because the pressure decay caused by the leak is reduced. Therefore, the SYSTEM LEAK CHECK is most effective when the volume of the closed system is minimized.

During molbloc-L operation, the SYSTEM LEAK CHECK also measures flow through the molbloc to help determine whether a leak is present upstream or downstream of the molbloc. Since molbloc-S is not capable of calculating meaningful flow values with the very small differential pressure present during this test, the SYSTEM LEAK CHECK operates differently for molbloc-L and molbloc-S operation, as described in the **Operation** sections immediately below.

#### *Note*

*The SYSTEM LEAK CHECK function uses the molbox2 high precision pressure and flow measurement capabilities to help determine whether a leak exists in the system to which the molbloc is connected. This feature assists the operator in flow measurement and calibration. The system to which the molbloc is connected is the responsibility of the user. Failures in the system leak check do not normally indicate defects in the molbox2 or molbloc itself. The molbox2 leak check is used to identify molbox2 failures.*

## Operation - molbloc-L Operation

#### *Note*

*The pass criteria is relative to the molbloc being used. If you use a 1E1-L or 5E1-L for system leak checks might result in false failures due to inability to maintain static pressure stability.*

To access the system leak check push  **<3leak check>**, **<2system>**.

The display shows:

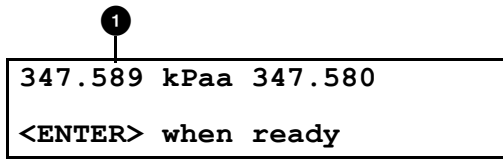

- ① - The pressure read by the upstream RPT (left), the downstream RPT (right) and the pressure unit of measure (middle).

This display assists in setting the leak check pressure. molbox2 has actuated internal valves to connect the upstream and downstream RPTs together, so they are both measuring an equal system pressure. (see [Figure 9](#)).

**Figure 9. molbox2 Internal Pneumatic Schematic - System Leak Check - Checking Offset and Stability**

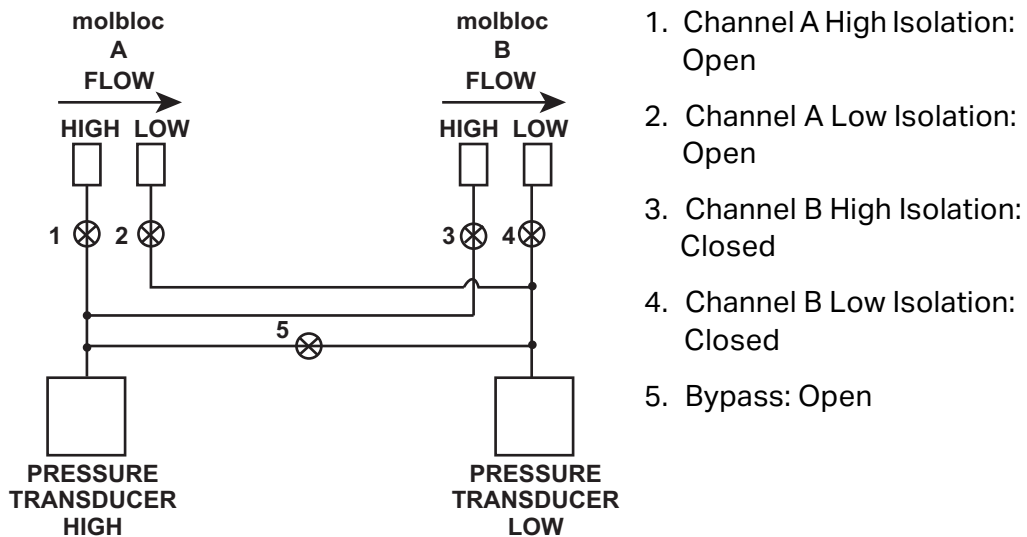

Close an isolation valve downstream or plug the exhaust of the flow system under test (downstream of the molbloc and the DUT if the molbloc/molbox is used to test another device).

Use the molbox2 display to read the pressure and set the pressure to the normal operating pressure.

*Note*

*For systems with mass flow controllers (MFCs):*

*Most MFCs are not intended to provide a complete gas shutoff and so they may not be suitable to close off the test system. If an MFC is downstream of the molbloc and its downstream port is open to atmosphere, it is best to close the system by connecting a cap to the MFC outlet fitting or by connecting a shutoff valve downstream. If the MFC valve is closed (most MFCs have normally closed valves) when the operating pressure is applied from the upstream side, most of the gas will be stopped by the MFC valve and will not immediately fill the volume between the MFC valve and the downstream cap or valve. If this happens, the gas may leak by the MFC valve to fill this volume during the test and cause a pressure decay and an apparent system leak. The solution is to send a setpoint signal to the MFC to open the MFC valve while pressurizing the system. Then close the MFC valve (remove the setpoint signal) after the system is pressurized to avoid heating of the test gas by the energized valve.*

Next, close an isolation valve upstream of the molbloc so the gas supply is no longer open to the system under test. Once the pressure has stabilized, push .

The display shows:

347.587 kPaa	347.583
WAIT: 30	

The molbox2 is checking:

- For pressure and temperature stability before running the system leak test
- That the disagreement between the two RPTs is not excessive

After 30 seconds, if the stability check is not passed, the Product indicates possible errors that include:

- If the pressure was not stable: leak is too large to continue
- If the molbloc temperature change was too great to find leaks
- If the offset between the RPTs was too great, check tare

If any of these prompts occurs, check the external system for leaks and run the molbox2 leak check before you proceed. If the tare was excessive, tare the molbox2 RPTs before you run the leak check again (see [<1tare>](#)).

Once the pressure stability/offset check has been successfully completed, molbox2 shows:

347.587 kPaa	347.583
0.000 sccm [ENT]	

Push , the molbox2 valves actuate to set up the system leak check configuration which is identical to the normal operating configuration (see [Table 11](#)).

The display becomes:

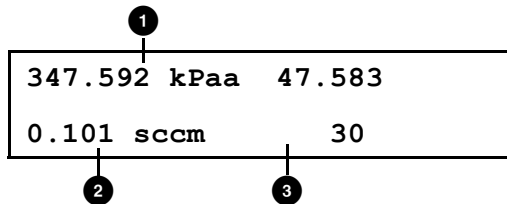

- ❶ - Pressure read by the upstream RPT (left), the downstream RPT (right) and the pressure unit of measure (middle).
- ❷ - Current measured flow.
- ❸ - Time remaining in the leak check in seconds.

molbox2 measures pressure and flow for a 40 second countdown. After the countdown has elapsed, molbox2 shows its conclusion from the measurements. The display will indicate if there is an upstream leak, a downstream leak, or if the leak check passed. Upstream and downstream refer to the possible location of the leak relative to the position of the molbloc and the normal flow direction in the system. If you are unable to locate a leak in the flow path components, check or replace the upstream and downstream molbloc to molbox pressure tubes and their connectors and retry the test. They are a critical part of the pneumatic system and if a significant leak is present in these tubes, it will cause an error in flow measurement.

### Operation - molbloc-S Operation

In molbloc-S operation, SYSTEM LEAK CHECK is a one-part test which tests for pressure decay in the closed system.

To access the system leak check, push  and select **<3leak check>**, **<2system>**.

The display shows:

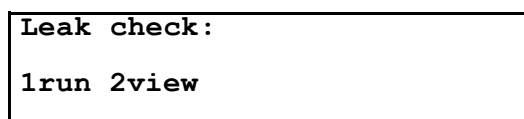

Select **<2view>** to see the test results screen (see below) with the results from the most recent leak test.

To run the leak test, select **<1run>**.

molbox2 actuates internal valves to connect the upstream and downstream RPTs together, so they both measure an equal system pressure (see [Figure 10](#)).

**Figure 10. molbox2 Internal Pneumatic Schematic - System Leak Check On Channel A - Checking Offset and Stability**

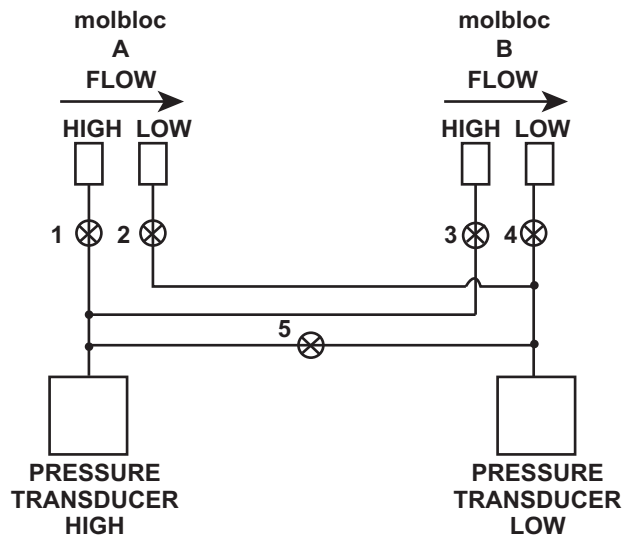

1. Channel A High Isolation: Open
2. Channel A Low Isolation: Open
3. Channel B High Isolation: Closed
4. Channel B Low Isolation: Closed
5. Bypass: Open

Close an isolation valve downstream or plug the exhaust of the flow system under test (downstream of the molbloc and the DUT if the molbloc/molbox is used to test another device).

Open an isolation valve upstream of the molbloc to allow the working pressure to pressurize the system.

*Note*

*For systems with mass flow controllers (MFCs)*

*Valves in most MFCs are not intended to provide a complete gas shutoff and so they may not be suitable to close off the test system. If an MFC is downstream of the molbloc and its downstream port is open to atmosphere, it is best to close the system by connecting a cap to the MFC outlet fitting or by connecting a shutoff valve downstream. If the MFC valve is closed (most MFCs have normally-closed valves) when the operating pressure is applied from the upstream side, most of the gas will be stopped by the MFC valve and will not immediately fill the volume between the MFC valve and the downstream cap or valve. If this happens, the gas may leak by the MFC valve to fill this volume during the test and cause a pressure decay and an apparent system leak. The solution is to send a setpoint signal to the MFC to open the MFC valve while pressurizing the system. Then close the MFC valve (remove the setpoint signal) after the system is pressurized to avoid heating of the test gas by the energized valve.*

Next, close the isolation valve upstream of the molbloc so the gas supply is no longer open to the system being checked. Once the pressure has had time to stabilize, push **ENTER**.

The next display shows:

```
ENTER to start
60 s leak check
```

Push **ENTER** to begin the test.

The next display shows:

```
1
199.167 kPa a
leak testing 60s
2 3
```

1. The average pressure from the two molbox2 RPTs.
2. Current absolute pressure measurement in active pressure unit of measure.
3. SYSTEM LEAK CHECK count down in seconds.
4. Push **ESC** to abort the leak test.

To restart the test and reset the leak test timer, push **ENTER** while the test is in progress.

When the test completes, a test results screen shows:

```
1 2
ΔP -0.0720 kPa
Rate -0.0012 kPa/s
3
```

- 1 - The total change in average pressure over the test interval.
- 2 - The currently selected pressure unit of measure.
- 3 - Average rate of pressure change, per second, during the test.

Since flow systems using molbloc-S may use widely varying flow rates and tubing sizes, and test volumes may be quite large, it is difficult to predict what size pressure rate of change is acceptable to avoid significant flow errors. Your best guide may be to run the SYSTEM LEAK CHECK often with your hardware, find a typical rate of change which represents a sound setup, and attempt to match that rate each time. You should be able to achieve a rate of change smaller than 0.01 % / second of the absolute line pressure.

If you observe a relatively large leak rate and are unable to locate a leak in the flowpath components, check or replace the upstream and downstream molbloc to molbox pressure tubes and their connectors and retry the test. They are a critical part of the pneumatic system and if a significant leak is present in these tubes, it causes an error in flow measurement.

## <4AutoZ>

### **Purpose**

To offset the molbox2 reference pressure transducers (RPTs) relative to a reference value in order to compensate for possible changes in RPT zero between full recalibrations.

### **⚠ Caution**

**To assure operation within measurement uncertainty specifications (see [Reference Pressure Transducer \(RPT\) Specifications](#)), Fluke Calibration recommends that AutoZ be run (the value of  $P_{\text{offset}}$  updated) whenever molbox2 is exposed to temperature changes exceeding  $\pm 15\text{ }^{\circ}\text{C}$  ( $36\text{ }^{\circ}\text{F}$ ).**

**Improper use of the AutoZ function can cause out of tolerance pressure measurements. AutoZ should be used only by qualified personnel for the purpose of rezeroing the molbox2 reference pressure transducer absolute pressure measurement function.**

### **Principle**

#### **AutoZ Purpose and Principle**

The main component of the change over time of the molbox2 RPTs is change in zero or offset, independent of span. Offsetting or *rezeroing* molbox2 RPTs relative to a reference between recalibrations allows measurement uncertainty specifications to be maintained with less frequent full calibrations. The molbox2 AutoZero function (AutoZ) provides full on-board support for the rezeroing process to simplify its application by the user.

The AutoZero function uses three values:

- **$P_{\text{std},0}$** : The absolute pressure value indicated by the AutoZ reference, the device that is acting as the reference relative to which to offset the RPT.

The pressure at which AutoZ is done is normally atmospheric pressure and the  $P_{\text{std},0}$  value can be supplied a) by manual entry, or b) automatically from a Fluke Calibration RPMx Reference Pressure Monitor.

- **$P_{u,0}$** : The absolute pressure reading of the RPT, with no AutoZ offset, at the time AutoZ is done.

- **P<sub>offset</sub>**: The difference between the absolute pressure reading of the RPT with no AutoZ offset (**P<sub>u,0</sub>**) and the indication of the AutoZ reference (**P<sub>std,0</sub>**):

$$P_{\text{offset}} = P_{u,0} - P_{\text{std},0}$$

**P<sub>offset</sub>** represents the change in zero of the RPT relative to the AutoZ standard (**P<sub>std,0</sub>**). The AutoZ function manages the determination, storage and application of **P<sub>offset</sub>** for both molbox2 RPTs in absolute mode. The AutoZ handles both molbox2 RPTs simultaneously as they are of the same range and always used together.

The source of **P<sub>std,0</sub>** must be an absolute pressure, nominally atmospheric pressure, with uncertainty significantly better than that of the RPT that is being AutoZeroed (see [Reference Pressure Transducer \(RPT\) Specifications](#)). Accomplished this with a variety of digital barometers or with a piston gauge able to set absolute pressure.

When the RPTs are used with AutoZ ON, absolute pressure is calculated as:

$$P_{\text{abs}} = P_{u,0} - P_{\text{offset}}$$

When RPTs are used with AutoZ OFF, **P<sub>offset</sub>** is ignored.

When the RPT is calibrated, **P<sub>offset</sub>** is set to zero. **P<sub>offset</sub>** is then redetermined at regular intervals using the AutoZ function. The most recent value of **P<sub>offset</sub>** is applied to the RPT reading to correct for change in zero over time.

### Recommendations for the Use of the AutoZ Function

Use the AutoZ function to improve the stability over time of molbox2 RPTs and maximizing the recalibration interval by compensating for change in zero between full recalibrations. To use this feature:

- Always leave AutoZ ON when operating **if** the AutoZ routine has been run regularly using a valid atmospheric reference.
- Run AutoZ to update **P<sub>offset</sub>** only when a reference whose measurement uncertainty is known to be significantly better than that of the molbox2 RPTs is available. Though it may not be practical and generally is not necessary, the best possible reference with which to run AutoZ in absolute measurement mode is a gas operated piston gauge (such as a Fluke Calibration PG7601) applying an absolute pressure near atmospheric pressure to the molbox2 test port. The best day to day reference is a properly calibrated Fluke Calibration RPM4 with a BA100K RPT interfaced directly as an external device to the molbox2 COM2 port.
- Allow the molbox2 to stabilize at atmospheric pressure and ambient temperature for 10 to 15 minutes before running AutoZ.

#### Note

*If AutoZ is on, the AutoZ value is applied while running the calibration of molbox RPTs and an AutoZ indication is included in the run calibration screen (See [View RPT outputs](#)).*

## Operation

To access the AutoZ function push , **<4AutoZ>**.

The display shows:

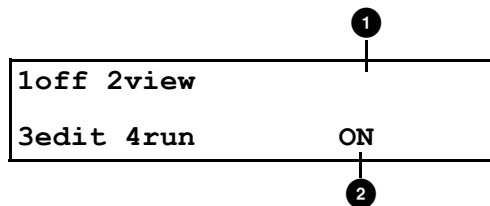

① - Active RPT designator.

② - Indication of whether AutoZ is currently ON or OFF for this RPT and measurement mode.

- Select **<1off>** (or **<1on>**) to change the AutoZ status.
- Select **<2view>** to view the current values of  $P_{offset}$  for the two RPTs.

### Note

$P_{offset}$  should be zero when the molbox2 is new or has just been calibrated.

- Select **<3edit>** to edit the values of  $P_{offset}$ .

### Note

The value of  $P_{offset}$  is always shown and entered in Pascal (Pa).

- Select **<4run>** to run the AutoZ routine which determines and activates  $P_{offset}$  values by measurement of  $P_{std,0}$  (see [Run AutoZ](#))

## Edit AutoZ

### ⚠ Caution



Use the edit AutoZ function with caution as entering inappropriate values and turning ON AutoZ may result in out of tolerance measurements. In normal operation, the value of the AutoZ offset,  $P_{offset}$ , should be changed with the run AutoZ function (see [molbloc-S Operation](#)). Before you edit  $P_{offset}$ , see Section **<4AutoZ>**, Principle.

To edit the current **P<sub>offset</sub>** values, push , **<4AutoZ>**, **<3edit>**.

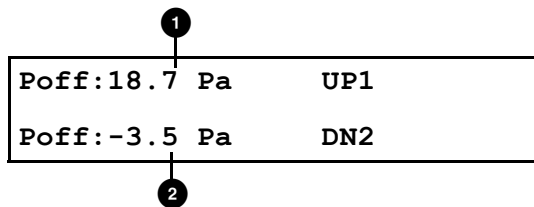
The display shows:



- ① - Edit field for the value of **P<sub>offset</sub>** of the upstream (1, Hi) RPT.
- ② - Edit field for the value of **P<sub>offset</sub>** of the downstream (2, Lo) RPT.

Edit the **P<sub>offset</sub>** value(s) and push  to activate the new value(s). Push  to abandon changes.

*Note*

*The value of **P<sub>offset</sub>** is always shown and entered in Pascal (Pa).*

### Run AutoZ

Run AutoZ compares the current RPT reading to a reference, **P<sub>std,0</sub>**, at atmospheric pressure to determine a new value of **P<sub>offset</sub>**. The value of **P<sub>offset</sub>** is then used by AutoZ to automatically correct the RPT for possible change in zero over time (see [<4AutoZ>](#), Principle).

There are 3 program limits on the entry of **P<sub>std,0</sub>** in place to reduce the possibility of erroneous entries from either method, limits given in kPa absolute but directly convertible to the current unit of measure:

1. The entry must be within the limits of 70 kPa to 110 kPa absolute.
2. If the entry is  $\geq 0.01$  % of nominal full scale from the current reading of either RPT, the molbox2 warns that the value is high for the specific transducer(s) but accept the entry.
3. If the entry is  $\geq 0.02$  % of nominal full scale from the current reading of either RPT, the molbox2 warns that the value is too high for the specific transducer(s) and reject the entry.

In the case of 3), the pressure calibration of the molbox2 RPTs or the accuracy or calibration of the pressure reference used to obtain **P<sub>std,0</sub>** should be double-checked.

While an entry within the limits of 1) or 2) is acceptable, if running AutoZ, results in a value of **P<sub>offset</sub>** that is  $>\pm 0.005\%$  FS of the span of the RPT that is being AutoZeroed, the RPT and/or the reference used as the source of **P<sub>std,0</sub>** may be out of tolerance or the AutoZ process may have been faulty. Before you activate a new **P<sub>offset</sub>**  $>\pm 0.005\%$  FS of the active RPT, check to be sure that both the RPT and the reference were in good working order, properly vented to stable atmospheric pressure, at the same height, and reading in the same pressure units when AutoZ was run. A good laboratory practice would be to keep a log of the resulting AutoZ **P<sub>offset</sub>** values for the two transducers over time to look for trends.

To access run AutoZ, push , **<4AutoZ>**, **<4run>**.

The display shows:

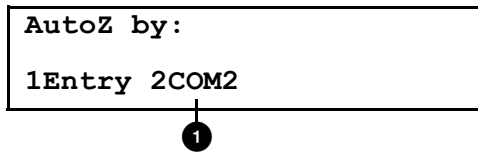

**1** - Selection of source of **P<sub>std,0</sub>** reference from which to AutoZ.

Select **<1Entry>** to enter the value of **P<sub>std,0</sub>** from the keypad.

Select **<2COM>** to read the value of **P<sub>std,0</sub>** automatically from a Fluke Calibration RPMx connected to a molbox2 COM2 communications port.

When AutoZ is run, the molbox2 internal valves are actuated to connect both molbox2 RPTs to the channel A, Hi port on the molbox2 rear panel (see [Figure 14](#)). Be sure the channel A, Hi port is fully open to atmosphere when running AutoZ. Note that the molbox2 quick connectors and molbox2 to molbloc pressure lines are self sealing and therefore DO NOT open to atmosphere unless a quick connector stem is inserted. Use a quick connector stem (Fluke Calibration P/N 3068652, equivalent to Swagelok SS QM2 S 200) supplied with the molbox2 accessories to open the port to atmosphere.

*Note*

*Allow the molbox2 to stabilize at atmospheric pressure and ambient temperature for 10 to 15 minutes before running AutoZ.*

*If running AutoZ results in a value of  $P_{offset}$  that is  $>\pm 0.005\%$  FS of the span of the RPT that is being AutoZeroed, the RPT and/or the reference used as the source of  $P_{std,0}$  may be out of tolerance or the AutoZ process may have been faulty. Before you activate a new  $P_{offset} >\pm 0.005\%$  FS of the active RPT, check to be sure that both the RPT and the reference were in good working order, properly vented to stable atmospheric pressure, at the same height, and reading in the same pressure units when AutoZ was run.*

*When the run AutoZ selection is made, if a HEAD correction is currently active (see <8Head> the head correction is momentarily disabled while running AutoZ to avoid zeroing out the head value.*

*The value of  $P_{offset}$  is always shown and entered in Pascal (Pa).*

### Run AutoZ by Entry

Use AutoZ to enter the value of  $P_{std,0}$  (see <4AutoZ>, Principle) from the molbox2 front panel. This provides a simple way of AutoZeroing relative to an independent reference device such as a house barometer that does not interface directly with molbox2.

To access run AutoZ by entry, push  <4AutoZ>, <4run>, <1Entry>.

The display shows:

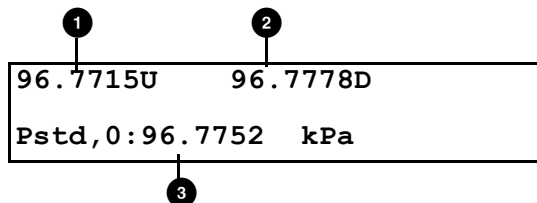

- ❶ - Real time reading (without head correction) of upstream (1, Hi) RPT in unit of measure on line 2.
- ❷ - Real time reading (without head correction) of downstream (2, Lo) RPT in unit of measure on line 2.
- ❸ - Entry field for the value of  $P_{std,0}$  in the current pressure unit of measure.

Enter the value of the AutoZ reference ( $P_{std,0}$ ) in the same unit of measure as the display and push . molbox2 logs the readings and calculates a new AutoZ offset value.

The next display shows:

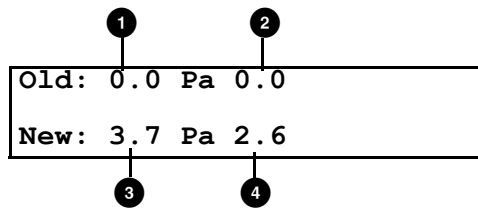

- ❶ - Currently active/previous value of  $P_{\text{offset}}$  for the upstream (1, Hi) RPT.
- ❷ - Currently active/previous value of  $P_{\text{offset}}$  for the downstream (2, Lo) RPT.
- ❸ - New value of  $P_{\text{offset}}$  for the upstream (1, Hi) RPT for the AutoZ that was just run.
- ❹ - New value of  $P_{\text{offset}}$  for the downstream (2, Lo) RPT for the AutoZ that was just run.

Push **ENTER** to activate the new values of  $P_{\text{offset}}$  or **ESC** to start over with entry of a new AutoZ reference ( $P_{\text{std},0}$ ) value.

#### Note

*The value of  $P_{\text{offset}}$  is always in Pascal (Pa). The value of  $P_{\text{std},0}$  is entered in the current pressure unit of measure.*

### Run AutoZ by COM2

AutoZ by COM2 allows a Fluke Calibration RPMx Reference Pressure monitor connected to the molbox2 COM2 to act as the AutoZ reference (source of  $P_{\text{std},0}$ ) (see [<4AutoZ>](#), Principle). The RPMx is read and the new  $P_{\text{offset}}$  is calculated automatically.

To access run AutoZ by COM2 push **4 TARE**, **<4AutoZ>**, **<4run>**, **<2COM2>**.

#### Note

*For molbox2 to communicate with an RPMx connected to its COM2 port, the molbox2 and the RPMx RS-232 interfaces must be set up properly (see [COM1 and COM2](#)). If the molbox2 is unable to locate an RPM ON COM2 when running AutoZ by COM2, it times out after 6 seconds and shows an error message.*

If molbox2 is able to communicate with an RPMx on its COM2 port, the display shows:

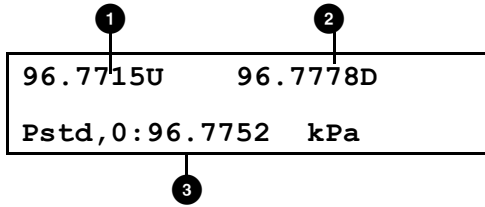

- ❶ - Real time reading (without head correction) of upstream (1, Hi) RPT in unit of measure on line 2.
- ❷ - Real time reading (without head correction) of downstream (2, Lo) RPT in unit of measure on line 2.
- ❸ - Real time reading of the RPMx connected to molbox2 COM2 to provide the value of AutoZ **P<sub>offset</sub>**.

Observe the pressure outputs verify that they are stable. A 10 minute to 15 minute wait, after venting, is recommended before running AutoZ. When ready, push **ENTER** to cause AutoZ to run. molbox2 logs both RPT readings and calculates a new AutoZ offset value.

The display shows:

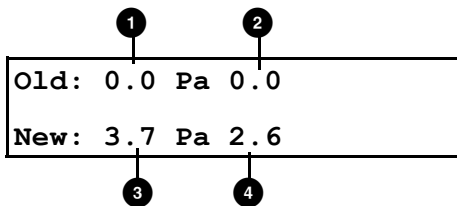

- ❶ - Current/previous value of **P<sub>offset</sub>** for the upstream (1, Hi) RPT.
- ❷ - Current/previous value of **P<sub>offset</sub>** for the downstream (2, Lo) RPT.
- ❸ - New value of **P<sub>offset</sub>** for the upstream (1, Hi) RPT for the AutoZ that was just run.
- ❹ - New value of **P<sub>offset</sub>** for the downstream (2, Lo) RPT for the AutoZ that was just run.

Push **ENTER** to activate the new values of **P<sub>offset</sub>** or **ESC** to start over.

*Note*

*The value of **P<sub>offset</sub>** is always displayed and entered in Pascal (Pa).*

## <5BPR> (molbloc-S Operation Only)

### Purpose

To quickly measure the molbloc-S upstream and downstream pressure and calculate and show the BPR (back pressure ratio) when molbox2 is in a molbloc-S BPR mode which would not otherwise measure the BPR.

### Note

*The <5BPR> menu selection is only present during molbloc-S operation.*

### Principle

molbox2 uses the back pressure ratio, or BPR (the ratio of the molbloc-S downstream absolute pressure to the upstream absolute pressure) to determine whether the flow through the throat of the molbloc-S Venturi nozzle is critical and flow measurements within predictable uncertainty limits can be made with molbloc-S (see [molbloc-S BPR Limits](#)). When operating molbox2 with molbloc-S, the user may select different BPR monitoring modes (see [<9BPR>](#)). Depending on which BPR mode is selected, the BPR value is not always measured. The BPR function allows the user to measure and show BPR directly at any time regardless of which BPR mode is selected.

### Operation

Select , **<5BPR>**.

The display shows:

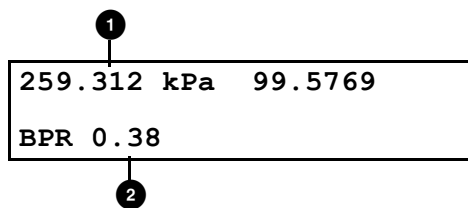

- 1 - The current pressure read by the upstream (left) and downstream (right) RPTs without taking into account the current tare value. These are untared readings in the current pressure unit of measure.
- 2 - The current BPR (ratio of downstream to upstream absolute pressure).

Push  or  to exit the BPR function and return to the previous RUN screen and BPR mode.

## [P&T] (Pressure and Temperature)

### Purpose

 - To provide continuous display of the pressures measured by molbox2, the Reynolds number of the flow through the molbloc, the temperature of the molbloc and other pressure measurement information depending on whether the molbox2 is used with molbloc-L or molbloc-S.

## Principle

molbox2 continuously measures pressures and molbloc temperature and uses these measurements to calculate flow.

The pressure at the molbloc upstream and downstream ports is read by two absolute Reference Pressure Transducers (RPTs). In molbloc L operation, the flow is calculated from the differential pressure across the molbloc. The differential pressure is calculated as the difference between the two, tared, absolute RPTs (upstream - downstream) and is shown in the molbloc-L mode pressure screen.

In molbloc-S mode, the flow is calculated from the molbloc-S upstream pressure. The upstream pressure may be read by either one or both of the RPTs, depending on which BPR mode is in use (see <9BPR>). When the molbox2 is in a valve state called BPR OFF, the molbloc-S downstream pressure is not measured and both RPTs are used to measure the molbloc-S upstream pressure. Their readings are averaged to reduce the uncertainty of the molbloc-S upstream pressure measurement. An indicator is used next to the *downstream* RPT value to show whether the RPT is currently measuring the molbloc downstream or upstream pressure. Whenever the molbloc-S downstream pressure is measured, the BPR is calculated and shown in the P&T pressure screen. When both RPTs measure the upstream pressure (BPR OFF mode), the indicated pressure for both RPTs is adjusted to equal the average of the two using the dynamic tare and BPR is no longer shown.

Since the displays and operation of the P&T pressure screen are different for molbloc-L and molbloc-S, they are described separately in [molbloc-L Operation](#) and [molbloc-S Operation](#).

For temperature measurement, two Platinum Resistance Thermometers (PRTs) are embedded in each molbloc. These are connected to the molbox2 by the molbox2 to molbloc cable. The molbox2 ohmic measurement system reads the resistance of the PRTs and calculates molbloc temperature.

molbox2 continuously calculates the Reynolds number of the flow through the molbloc.

molbox2 current pressure and temperature readings as well as the Reynolds number of the current flow can be shown with the P&T function.

## molbloc-L Operation

### Operation

Push  from any run screen.

The display shows:

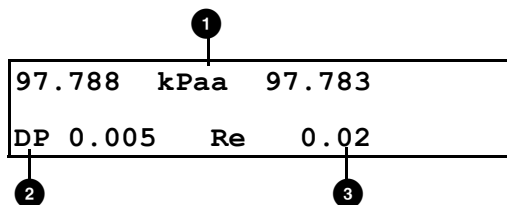

- ① - Pressure read by the upstream RPT (left), the downstream RPT (right) and the pressure unit of measure (middle).

- ② - The current differential pressure in the current pressure unit of measure. **<DP>** indicates the value is differential pressure.
- ③ - Current Reynolds number of the flow through the molbloc.

To toggle between the pressure screen and the temperature screen, push 5  
P&T again or the +/- key:

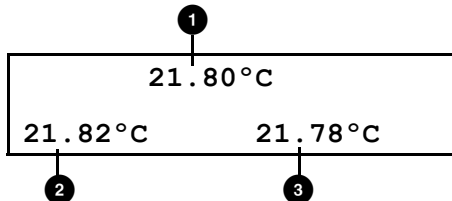

- ① - The average molbloc temperature in the current unit of measure (upstream + downstream/2).
- ② - The temperature measured by the upstream molbloc platinum resistance thermometer in the current unit of measure.
- ③ - The temperature measured by the downstream molbloc platinum resistance thermometer in the current unit of measure.

To leave the P&T function and return to the MAIN run screen, push ESC.

#### Note

To change the pressure and/or temperature unit of measure, see [<8PRESU>](#) and [<9TEMPU>](#).

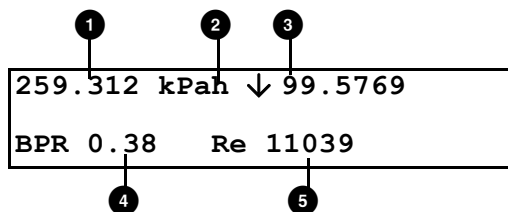

## molbloc-S operation

### Operation



- ① - The current pressure read by the upstream (left) and downstream (right) RPTs and the current pressure unit of measure (middle). In BPR OFF or Auto modes, tare is automatically applied to these readings. In BPR ON mode, tare is never applied.
- ② - **<h>** indicates a head pressure correction is applied or no character if no head correction.

- ③ - Arrow to indicate which pressure is being read by the *downstream* RPT. Down arrow indicates downstream pressure, up arrow indicates upstream pressure.
- ④ - The current BPR (ratio of downstream to upstream absolute pressure).
- ⑤ - Current Reynolds number.

Push  again or  to toggle between the pressure screen and the temperature screen:

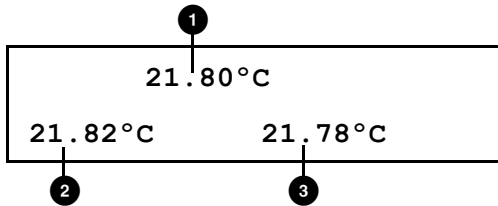

- ① - The average molbloc temperature in the current unit of measure (upstream + downstream/2).
- ② - The temperature measured by the upstream molbloc platinum resistance thermometer in the current unit of measure.
- ③ - The temperature measured by the downstream molbloc platinum resistance thermometer in the current unit of measure.

Push  to leave the P&T function and return to the MAIN run screen.

*Note*

*To change the pressure and/or temperature unit of measure, see <8PRESU> and <9TEMPU>.*

**[DISPLAY]**

**Purpose**

 - To select the information shown on the second line of the display. For example, Averaging.

**Principle**

molbox2 supports a variety of ADVANCED FLOW MEASUREMENT functions that are shown on the second (bottom) line of the molbox2 display. In summary, the available DISPLAY functions included are:

**RATE:** Calculates and shows the current rate of change of flow in current flow units/second (see <1Rate>). This function indicates the stability of the measured flow. Use RATE as an indication of positive or negative leak rate and as a *go/no go* criterion for when to take data when comparing molbox2 and a DUT (for example, in a calibration).

**AVERAGE:** Calculates the average flow measurement over a user-specified period of time and shows the average, the standard deviation about the mean and a countdown in seconds to the next average (see [<2Avg> \(Average\)](#)). This function is often used to filter out flow noise in an unstable system or to gather a corresponding sample when comparing molbloc/molbox measurements to another device with a long integration time (for example, a volumetric flow standard). The magnitude of the noise is quantified by the standard deviation about the mean. A second screen allows the instantaneous flow values to be viewed during an averaging cycle.

**HI/LO:** Records and shows the maximum and minimum flows measured since HI/LO reset (see [<3 Hi/Lo>](#)). This function keeps track of the minimum and maximum flow observed over a period of time or to monitor whether a flow min/max limit has been exceeded.

**TOTAL:** Totalizes the mass or volume flowed over a period of time (see [<4Total> \(Totalizer\)](#)). Use TOTAL to measure total mass or volume over a period of time. Useful in calibration or verifying a totalizing flow device, when comparing molbloc/molbox to a gravimetric standard or to add or remove a specific quantity of mass or volume from a system.

**UNIT:** Shows the measurement of flow through the molbloc simultaneously in a second flow unit (see [<5Unit>](#)). This function is convenient when you work with an unfamiliar flow unit of measure to simultaneously display a familiar unit or any time a real time flow unit conversion is necessary.

**DEVIATION:** Continuously calculates and shows the deviation between the current flow measured by molbox2 and a target flow defined by the user (deviation = current flow - target) (see [<6Deviation>](#)). This function monitors the evolution of flow around and/or away from a set point.

**FREEZE:** Captures and shows the instantaneous flow value measured by molbox2 when you push  (see [<7Freeze>](#)). This function records the flow present at the time of an operator observed trigger event.

**CLEAN:** Blanks out the second line of the display (see [<8Clean>](#)). This function is used when a simple display of flow measured by the molbox2, without additional information, is necessary.

## Operation

To select a DISPLAY function, push  from the MAIN run screen.

The display shows:

```
1rate 2avg 3hi/lo
4total 5unit 6dev   ↓
7freeze 8clean
```

The cursor is on the active DISPLAY function. Select a DISPLAY function to return to the MAIN run screen with the selected function active.

See [\[DISPLAY\]](#), Principle for a summary of DISPLAY functions and [<1Rate>](#) through [<8Clean>](#) for detailed information on each DISPLAY function.

*Note*

*In molbloc-S operation, at times, the back pressure ratio, BPR, will be too high for molbox2 to calculate a meaningful flow value. When this occurs, the top line of the run screen display reads <BPR HI> and the bottom line shows the label <BPR> and the current measured BPR value. This display has priority over the appearance of the display functions described in this section, but the display returns to normal when the BPR returns to a usable level for molbloc-S measurements (see [molbloc-S BPR Limits](#)).*

*The default DISPLAY function is RATE which causes the second line of the display to show <R> followed by the current rate of change of flow in current flow unit of measure per second (see [<1Rate>](#)).*

[<1Rate>](#)

**Purpose**

To activate the RATE DISPLAY.

*Note*

See [\[DISPLAY\]](#), Principle.

**Operation**

To activate the RATE DISPLAY push  and select [<1rate>](#). Selecting [<1rate>](#) returns to the MAIN run screen with the RATE DISPLAY active.

With the RATE DISPLAY active, the MAIN run screen shows:

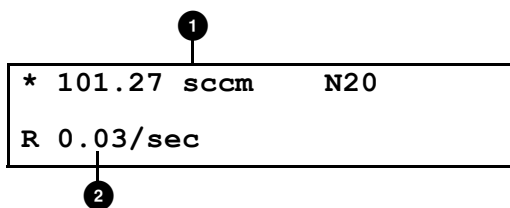

- ❶ - Standard MAIN run screen top line.
- ❷ - Current rate of change of flow in current flow unit of measure per second.

Note

The RATE DISPLAY is different and separate from the stability setting which sets the stability criterion on which the Ready/Not Ready indication is based (see [Flow Ready/Not Ready Indication](#) and [<2stab>](#)). The RATE DISPLAY only causes the current rate of change to be shown and has NO affect on the stability setting or the Ready/Not Ready condition.

To go to a DISPLAY other than RATE, push  and make a new DISPLAY choice.

<2Avg> (Average)

**Purpose**

To activate the AVERAGE DISPLAY and/or adjust the period of time over which averaging occurs.

Note

See [\[DISPLAY\]](#), Principle.

**Operation**

To access the AVERAGE DISPLAY, push  and select **<2avg>**.

The display shows:

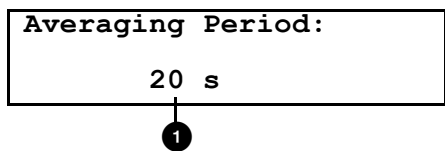

① - Edit field for averaging period in seconds. Default is 20. Minimum 3, maximum 999.

Edit the averaging time period if necessary. Push  to return to the MAIN run screen with the AVERAGE DISPLAY active.

With the AVERAGE DISPLAY active, the MAIN run screen is:

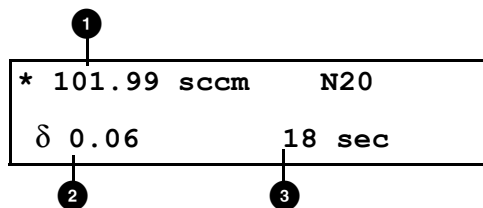

① - Average flow measured over last completed averaging period.

② - Standard deviation of last completed averaging period.

- ③ - Countdown in seconds until completion of on-going averaging period.

The AVERAGE DISPLAY has a second screen that allows the instantaneous flow readings to be viewed while an averaging cycle is running. This screen is available only if the molbox2 MFC control option is NOT present or OFF. If the molbox2 MFC control option is not present or OFF, push  to toggle between the MAIN run AVERAGE screen and the instantaneous values AVERAGE screen. If the molbox2 MFC control option is ON, push  to access the MFC averaging screens. The MFC averaging screens are the equivalent of the normal MFC screens but the values are averaged for the averaging time.

The instantaneous AVERAGE screen is:

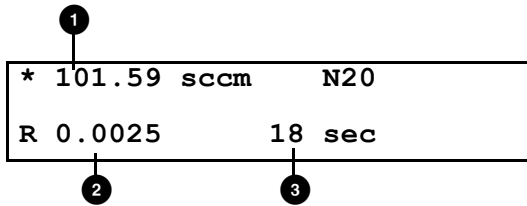

- ① - Instantaneous flow value at molbox2 normal integration rate.
- ② - Countdown in seconds until completion of on-going averaging period.
- ③ - Current rate of change of flow in flow unit of measure/second.

<3 Hi/Lo>

**Purpose**

To activate the HI/LO DISPLAY.

*Note*

See [\[DISPLAY\]](#), Principle.

**Operation**

To activate the HI/LO DISPLAY, push  and select <3hi/lo>. Select <3hi/lo> to reset the HI/LO values and return to the MAIN run screen with the HI/LO DISPLAY active.

With the HI/LO DISPLAY active, the MAIN run screen is:

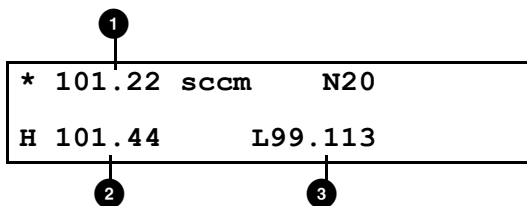

- ① - Standard MAIN run screen top line.
- ② - Highest flow observed since HI/LO reset.
- ③ - Lowest flow observed since HI/LO reset.

The HI/LO values change each time a new HI or LO flow value occurs. Push  to reset the HI/LO record at any time and allow a HI/LO reset without going back through the DISPLAY menu.

*Note*

*When DISPLAY is set to HI/LO, the MFC indicator of the optional MFC function is not included on the second line of the molbox2 display as the HI/LO DISPLAY occupies the entire second line of the molbox2 display (see [\[MFC\] \(Optional\)](#)).*

*The set point of the optional MFC function cannot be changed in the HI/LO display because  is used by the DISPLAY function. MFC set point can only be entered in the RATE, UNIT or CLEAN DISPLAY functions.*

*Changing the flow unit of measure, the gas, the K factor or running a TARE function while in HI/LO resets the HI/LO record.*

To go to a DISPLAY other than HI/LO, push  and make a new DISPLAY choice.

<4Total> (Totalizer)

**Purpose**

To activate the TOTALIZER DISPLAY.

*Note*

See [\[DISPLAY\], Principle](#).

**Operation**

To activate the TOTALIZER DISPLAY, push , <4total>.

The display shows:

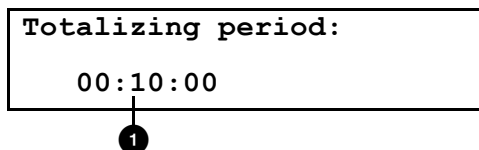

- ① - Edit field for time over which to totalize (hh:mm:ss). Default period is 00:10:00; maximum 99:59:59.

Edit the totalizing period as necessary. Push  to return to the MAIN run screen with the TOTALIZER DISPLAY active.

With the TOTALIZER DISPLAY active, the MAIN run screen shows:

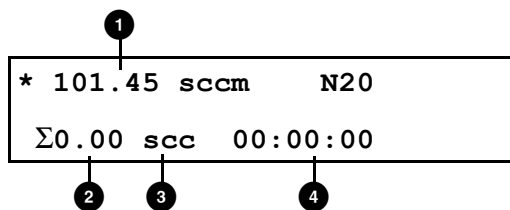

- ❶ - Standard MAIN run screen top line.
- ❷ - Total mass or volume accumulated over elapsed totalizing run time.
- ❸ - Units of measure of mass or volume (derived from the current flow unit) of the totalized value (see [Table 44](#)). The units of measure are not shown if the screen space is needed to show a large totalized value.
- ❹ - Elapsed totalizing time (hh:mm:ss). Always starts from zero and counts up until totalizing period elapses.

To start totalizing, push . The elapsed time counter starts and the total mass or volume begins to accumulate. Totalizing continues until the set totalize period is complete. When the totalizing period is complete, molbox2 sounds three beeps and shows the totalizing complete screen in which the total flow or volume and elapsed totalizing time are frozen with totalizing time NOT flashing.

To start a new totalizing run from the totalizing complete screen, push . This clears the previous total, resets to the totalizing timer, and starts totalizing.





#### Note

*When DISPLAY is set to TOTALIZE, the MFC indicator of the optional MFC function is not included on the second line of the molbox2 display as the TOTALIZE DISPLAY occupies the entire second line of the molbox2 display (see [\[MFC\] \(Optional\)](#)).*

*The set point of the optional MFC function cannot be changed in the TOTALIZE display because is used by the DISPLAY function. MFC set point can only be entered in the RATE, UNIT, or CLEAN DISPLAY functions.*

*To view a split total and/or to start a new totalizing run with a new run time, push while totalizing (see [Viewing a Split Total and/or Starting a New Totalizing Run with a New Run Time](#) of this section). To change totalizing run time any other time, push and select **<4total>**.*

*Certain functions cannot be executed while totalizing. These functions include change K, change gas, change flow unit of measure, tare. If **<Access restricted while totalizing>** is shown when a function key is pushed during totalizing, the function is one that cannot be executed while totalizing. To execute the function, abort the totalizing run or wait until after the run has completed. This feature is to avoid accidentally aborting or corrupting a totalizing run.*

To set a new totalizing time without going back through the  menu, push  and select **<2new>** from the TOTALIZER screen. To freeze a split total without stopping the totalizing run, push  or  while totalizing (see Viewing a Split Total and/or Starting a New Totalizing Run with a New Run Time below in this section).

**Table 18. Flow Units and Corresponding Total Mass or Volume Units**

Flow Unit	Total Mass or Volume Unit
mol/s	mol
kg/s	kg
mg/s	mg
slh or slm	sl
sccm	scc
scfh or scfm	scf
Ulm	ul
Uccm	ucc
ucfm or ucfh	ucf
plm or plh	pl
pccm	pcc
pcfm or pcfh	pcf
lm or lh	l
ccm	cc
m3m or m3h	m3
cfm or cfh	cf

### <5Unit>



#### Purpose

To activate the UNIT DISPLAY.

#### Note

See [\[DISPLAY\]](#), Principle.

#### Operation

To activate the UNIT DISPLAY, push  and select **<5unit>**. Select the unit of measure for the second line of the MAIN run screen display. The unit selection process is identical to that of the  key (see [\[UNIT\]](#)). Once the unit is selected, operation returns to the MAIN run screen with the UNIT DISPLAY active.

With the UNIT DISPLAY active the MAIN run screen shows:

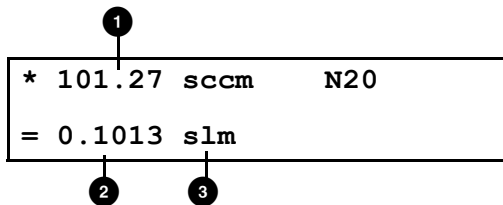

- ❶ - Standard MAIN run screen top line.
- ❷ - Flow equivalent of the current measured flow in the alternate flow unit of measure.
- ❸ - Alternate flow unit of measure selected in UNIT DISPLAY.

**⚠ Caution**

The reference temperature setting for the user units, for example, uccm and ulm, (see [Volumetrically Based Mass Flow Units at Various Reference Temperatures \(UXXX\)](#)) and the temperature and pressure settings for volume units (see [Volume Flow Units \(vlm\)](#)) apply to the units in the main UNIT selections as well as the UNIT DISPLAY selection. Therefore, it is not possible to simultaneously display user units or volume units with different reference temperatures and/or pressures. When you change the temperature or pressure setting for one type of unit, you change it for that type of unit wherever it is used. It is possible to show the difference between volumetrically based mass flow units at 0 °C and another temperature by choosing the s version, for example, sccm, for 0 °C as the main unit and a user unit with a different reference temperature as the UNIT DISPLAY, or vice-versa.

*Note*

To go to a DISPLAY other than UNIT, push  and make a new DISPLAY choice.

<6Deviation>

**Purpose**

To activate the DEVIATION DISPLAY and/or edit the deviation target.

*Note*

See [\[DISPLAY\]](#), Principle.

**Operation**

To activate the DEVIATION DISPLAY, push  and select <6dev>.

The display shows:

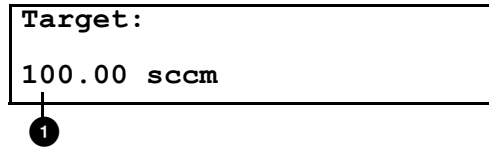

- ① - Edit field to edit the target value from which the deviations is to be measured.

Edit the target value. Push  to return to the MAIN run screen with DEVIATION DISPLAY active with the entered target value.

With the DEVIATION DISPLAY active, the MAIN run screen shows:

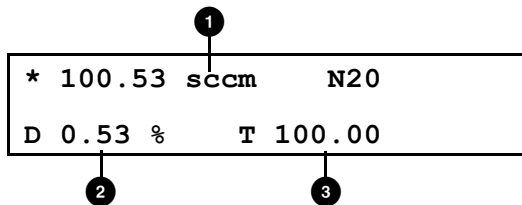

- ① - Standard MAIN run screen top line.
- ② - Target value in current flow unit of measure.
- ③ - Deviation of current flow from target value in % of reading.

*Note*

*Push  from the MAIN run screen when the DEVIATION DISPLAY is active to go directly to the target edit screen. This allows the target value to be changed without going through the DISPLAY menu.*

*The DEVIATION DISPLAY target value is the value from which % deviations (D) are measured by the DEVIATION DISPLAY following:*

$$D = (current\ flow - target) \times 100 / target$$

*To go to a DISPLAY other than DEVIATION, push  and make a new DISPLAY choice.*

**Purpose**

To activate the DEVIATION DISPLAY and/or edit the deviation target.

*Note*

See [\[DISPLAY\]](#), Principle.

**Operation**

To activate the DEVIATION DISPLAY, push  and select **<6dev>**.

The display shows:



- ① - Edit field to edit the target value from which the deviations is to be measured.

Edit the necessary target value. Push **ENTER** to return to the MAIN run screen with DEVIATION DISPLAY active when you use the entered target value.

With the DEVIATION DISPLAY active, the MAIN run screen shows:

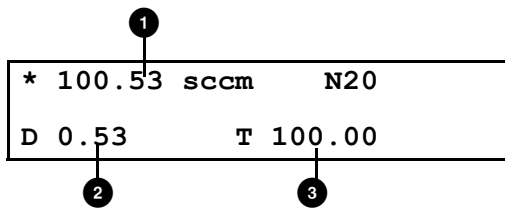

- ① - Standard MAIN run screen top line.
- ② - Target value in current flow unit of measure.
- ③ - Deviation of current flow from target value in current flow unit of measure.

*Note*

*When DISPLAY is set to DEVIATION, the MFC indicator of the optional MFC function is not included on the second line of the molbox2 display. The DEVIATION DISPLAY occupies the entire second line of the molbox2 display (see [\[MFC\] \(Optional\)](#)).*

*The set point of the optional MFC function cannot be changed in the DEVIATION display because **ENTER** is used by the DISPLAY function. MFC set point can only be entered in the RATE, UNIT, or CLEAN DISPLAY functions.*

*Push **ENTER** from the MAIN run screen when the DEVIATION DISPLAY is active to go directly to the target edit screen. This allows the target value to be changed without going through the DISPLAY menu.*

*The DEVIATION DISPLAY target value is the value from which deviations (D) are measured by the DEVIATION DISPLAY following:*

$$D = \text{current flow} - \text{target}$$

*If the flow unit is changed while the DEVIATION DISPLAY is active, the target value remains at the same numerical value. It is not converted to the new unit.*

*To go to a DISPLAY other than DEVIATION, push **6 DISPLAY** and make a new DISPLAY choice*

## <7Freeze>

### Purpose

To activate the FREEZE DISPLAY.

#### Note

See [\[DISPLAY\]](#), Principle.

### Operation

To activate the FREEZE DISPLAY push  and select **<7freeze>**. Select **<7freeze>** to return to the MAIN run screen with the FREEZE DISPLAY active.

With the FREEZE DISPLAY active, the MAIN run screen shows:

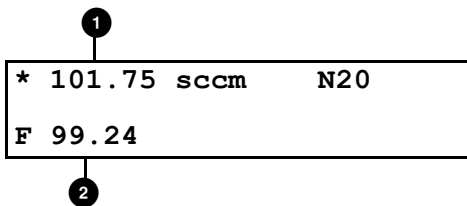



- ① - Standard MAIN run screen top line.
- ② - Flow measured in the current flow units when  was pushed (displays 0.00 by default when FREEZE DISPLAY first activates).

Push  to cause the current flow measured by the active molbox2 range to be captured and shown.

#### Note

*If the flow measurement unit is changed while the FREEZE DISPLAY is active, the FREEZE value defaults back to zero.*

*The set point of the optional MFC function cannot be changed in the FREEZE display because  is used by the DISPLAY function. MFC set point can only be entered in the RATE, UNIT, or CLEAN DISPLAY functions.*

To go to a DISPLAY other than FREEZE, push  and make a new DISPLAY choice.

## <8Clean>

### Purpose

To activate the CLEAN DISPLAY.

#### Note

See [\[DISPLAY\]](#), Principle.

## Operation

To activate the CLEAN DISPLAY, push  and select **<8clean>**. Select **<8clean>** to return to the MAIN run screen with the CLEAN DISPLAY active.

With the CLEAN DISPLAY active, the MAIN run screen shows:

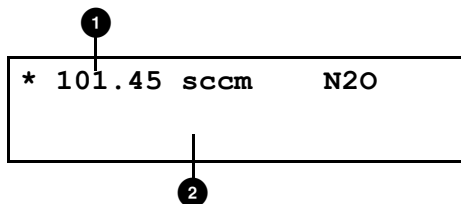

- ❶ - Standard MAIN run screen top line.
- ❷ - Clean second line.

### Note

The MFC indicator is not included in the MAIN run screen in the CLEAN DISPLAY function (see [\[MFC\] \(Optional\)](#)).

To go to a DISPLAY other than CLEAN, push  and make a new DISPLAY choice.

## [A/B]



### Purpose

 - To switch the active molbloc channel between channel A and channel B.

### Principle

See [molbloc Channel A and Channel B](#).

### Operation

Push  to change the active molbloc channel. The currently active channel is indicated by the lit RED LED below the molbox2 display. When the A/B function is operated, molbox2 actuates internal valves to change the molbloc channel that is connected to the molbox2 internal pressure transducers. Push  to also abort any A\_B mode that may be active (see [<4A\\_B>](#)).



### Note

When channels are changed with the A/B function, the molbloc is not initialized by the molbox2. When the molbloc connected to a channel is changed, use **<1molbloc>** in the SETUP menu (see [<1molbloc>](#)) to reinitialize. This causes the molbox2 to read and store the molbloc EEPROM information and assure that the newly-connected molbloc is properly identified and used.

## Channels, Functions and Settings

In general, molbox2 functions and settings are channel specific. They are set and stored individually for each channel so that changing settings for one channel does not change the setting for the other.

The only functions and settings that are NOT channel specific are:

Functions:  

Setup Menu: **<3adj>**

Special Menu: **<9BPR>**

### [MFC] (Optional)

#### Purpose

 - To turn the analog MFC control function ON and OFF and to select an MFC profile to be used when the MFC function is ON.







#### Note

*The MFC control function is an optional feature of molbox2 to set and read an external MFC with analog voltage or current signals. If the molbox2 does not include the MFC control function,  has no function.*

#### Operation



When you first push , the screen prompts you to select the channel.

The **MFC channel** refers to the channel of the optional MFC switchbox that can be purchased as an accessory to allow the MFC control function to be switched between up to five MFCs.

 disables the MFC control function. , , , , or  enables the MFC function and selects the corresponding channel on the MFC switchbox. If an MFC switchbox is not in use, select channel #1 when you activate the MFC function.



The operator is then prompted to select the profile.

The number refers to the MFC profile number (see [MFC Profiles](#) and **<5MFC>**). Edit the profile number to the necessary profile. When the profile number is entered, a summary of the profile is shown. Push  again to return to the MAIN run screen and the MFC function is active using the profile selected. **<MFC>** or **<MFM>** (depending on the device type of the selected profile) and the active channel number may be displayed in the bottom right corner of the MAIN run screen depending on the current display mode (see [\[DISPLAY\]](#)).



When the MFC function is ON, push  from the MAIN run screen or an MFC run screen to allow entry and execution of the MFC set point command. When the DISPLAY MODE is AVERAGE, HI/LO, TOTAL, DEVIATION or FREEZE, use  for the DISPLAY MODE (see [\[DISPLAY\]](#)). MFC set point commands cannot be entered in these DISPLAY MODES. MFC set points can only be entered in the RATE, UNIT, and CLEAN DISPLAY MODES.

*Note*

To  MFC set point, the DISPLAY MODE must be RATE, UNIT, or CLEAN. In other DISPLAY MODES, DISPLAY MODE uses .

Push  any time the MFC control function is active to cause an instant display of the current MFC profile summary and allow a quick check of the characteristics of the currently active MFC profile. Push  to return from the MFC profile screen to the last run screen.

### MFC Run Screens

When the MFC function is ON, the MAIN run screen is unchanged but **<MFC>** or **<MFM>** and the active MFC channel number are shown in the bottom right corner of the molbox2 display (in RATE, UNIT, and FREEZE DISPLAY modes only, see [\[DISPLAY\]](#)). Two or three, depending on the MFC profile in use, special MFC run screens can be accessed with . When you push  from the first MAIN run screen, the first MFC run screen shows:

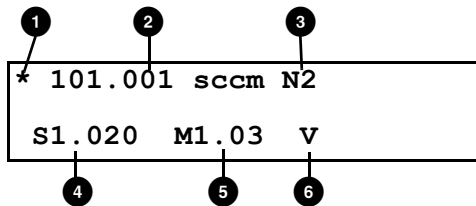

- ① - Ready/not ready indication.
- ② - Flow value and flow unit of the flow through the active molbloc as read by the molbox2.
- ③ - The gas that currently flows through the active molbloc.
- ④ - MFC set point set by the molbox2.
- ⑤ - MFC output measured by the molbox2.
- ⑥ - Unit of measure of MFC setpoint and output (V, mA, % FS or blank if flow units).

Push  from the first MFC run screen to cause the second MFC run screen to show (this screen is not present when MFC profile #1 or #2 is in use, see [MFC Profiles](#) and **<5MFC>**):

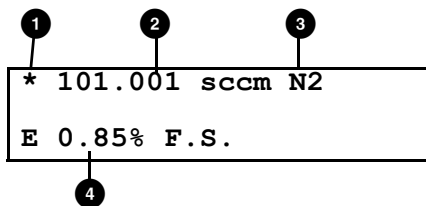

- ① - Ready/not ready indication.

- ② - Flow value and flow unit of the flow through the active molbloc as calculated by the molbox2.
- ③ - The gas that is currently being flowed through the active molbloc.
- ④ - The MFC measurement error in % calculate as:

$$\left( \frac{MFC - molbox1}{MFC F.S.} \right) \cdot 100$$

Push  from the second MFC run screen to cause the third MFC run screen to show (this is the second screen if MFC profile #1 or #2 is in use, see [MFC Profiles](#) and [<5MFC>](#)).

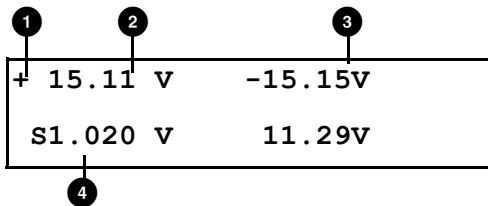

- ① - Positive MFC supply voltage.
- ② - Negative MFC supply voltage.
- ③ - Current MFC valve voltage.
- ④ - Current MFC set point.

### Summary

Push  to toggle the run screens from the MAIN run screen through the MFC run screens and back to the MAIN run screen.

### MFC Profiles

Use the MFC profiles to configure the MFC function. MFC profiles define the analog signal range of the MFC and the relationship between the analog signal range and the flow range of the MFC. This information allows molbox2 to operate with the correct signal for the current MFC and to convert the MFC analog signals to the corresponding flow or % FS values when necessary.

MFC profiles are created and edited in , [<5MFC>](#) (see [<5MFC>](#)).

### Units of Measure When Using the MFC Control Option

When the MFC function is active, the molbox2 flow units of measure are always the units of measure specified in the active MFC profile.

When the MFC function is active, unless the profile is #1 or #2, the flow unit of measure in which the flow through the molbloc is shown is determined by the flow unit of measure in the MFC profile.  selects the unit of measure of the MFC setpoint and output. The choices available are V or mA (depending on the active MFC profile's analog range), % FS or flow. The % FS selection causes MFC setpoint and output to be shown in % FS of the MFC which molbox2 calculates using the definition of analog range and flow range contained in the MFC profile. The flow unit selection causes MFC setpoint and output to be shown in the flow units of the MFC calculated with the definition of analog range, flow range and flow units contained in the MFC profile.

*Note*

*MFC profiles #1 and #2 are default profiles to work with the MFC function directly in analog units without an MFC flow range or units. Profile #1 is 0 V to 5 V, profile #2 is 4 mA to 20 mA. When the MFC function is active with profile #1 or #2 selected, the MFC units of measure are always V (profile #1) or mA (profile #2). The UNIT function selects the molbox2 flow measurement unit.*

**[RES]**

**Purpose**

 - To set the resolution of the flow through the molbloc and other flow display and entry values.

**Principle**

The resolution with which the flow measured by molbox2 is shown is adjustable. Use this feature to reduce the resolution when lower precision measurements are being made and additional digits might confuse or distract the operator.



The resolution setting determines the number of digits with which flow is shown. The necessary resolution is calculated based on the nominal full scale range of the molbloc in the current gas and flow unit of measure and then rounded to the furthest digit to the right (for example, resolution of 0.001 % on a 100 sccm molbloc is 0.001 sccm).

*Note*

*The default display resolution setting is 0.001 % of molbloc FS. The RES setting does not affect the resolution of flow information transmitted remotely. Remote information always has maximum resolution of 0.0001 % of molbloc FS.*

**Operation**

To access the resolution function, push .

Push  to decrease the resolution and  to increase the resolution. Each push changes the resolution by a factor of 10. Once the correct resolution is shown, push  to set the selected resolution and return to the main run screen.

*Note*

*The resolution setting affects the display of the measured flow as well as other indications and settings (for example, quantities shown by the  functions).*

## [Setup]

### Purpose

Push  to access a menu of commonly-used functions and features that do NOT have direct function keys. These functions include:

- <1molbloc>** To initialize a molbloc when it is connected to molbox2 and/or to identify the molblocs currently connected to molbox2 (see [<1molbloc>](#)).
- <2stab>** To change the stability limit that serves as the criterion for the flow Ready/Not Ready indication (see [<2stab>](#) and [Flow Ready/Not Ready Indication](#)).
- <3adj>** To set an adder and multiplier to adjust molbox2 flow readings (see [<3ADJ>](#)).
- <4A\_B>** To set molbox2 flow measurement modes that use the combination of two molblocs on channels A and B to measure flow (see [<4A\\_B>](#)).
- <5MFC>** To create, store and edit the MFC profiles used by the optional MFC function (see [<5MFC>](#) and [\[MFC\] \(Optional\)](#)).
- <6reg>** To turn regulation mode of the optional MFC function ON and OFF and to set the regulation period for the regulation mode (see [<6REG>](#)).
- <7flowU>** To customize the flow unit choices available under  (see [<7FLOWU>](#) and [\[UNIT\]](#)).
- <8presU>** To select/change the unit of measure in which molbox2 displays pressure values (see [<8PRESU>](#)).
- <9tempU>** To select/change the unit of measure in which molbox2 displays temperature values (see [<9TEMPU>](#)).



### Operation

To access the SETUP menu, push  from the MAIN run screen. The display shows:

```
1molbloc 2stab 3adj
4A-B 5MFC 6mode ↓
7flow 8presU 9tempU
```

See [<1molbloc>](#) to [<9TEMPU>](#) for detailed information on each SETUP function.

### Note

Some screens (for example, the *SETUP* menu) go beyond the two lines provided by the display. This is indicated by a flashing arrow in the second line of the display. Push  and  to move the cursor to access the lines that are NOT visible or directly enter the number of the hidden menu choice if you know it.

## <1molbloc>

### Purpose

To initialize a molbloc when it is connected to molbox2 and/or to identify the molbloc(s) currently connected to molbox2. To determine the gases with which a molbloc has been calibrated.



### Principle

molbox2 uses molbloc-specific calibration information contained in the molbloc EEPROM to determine whether it should operate in molbloc-L or molbloc-S mode and in its calculation of flow through the molbloc. For the molbox2 to correctly calculate the flow through the molbloc, the molbox2 must use information on the currently-active molbloc. molbloc EEPROM information is read and stored by molbox2 in the molbox2 power up sequence when molbox2 is turned on. Select , **<1molbloc>**.

Use the **<1molbloc>** function each time there is a change in the molbloc connected to a channel to assure that molbox2 uses the correct molbloc information on subsequent measurements. The **<1molbloc>** function can also be used to show identifying information on the molblobs currently connected to the molbox2 channels and to determine the gases with which the molbloc has been calibrated.

### Operation

To access the molbloc function push , **<1molbloc>**. The function activates for both channels without additional prompts or entries.

To view the gases with which the molbloc is calibrated, push  in the molbloc identification screen to view the molbloc gas list. After viewing, push  to return to the current run screen.

## molbloc-L and molbloc-S Size and Range Designations

Until mid-1999, molbloc-L elements (molbloc-S was not available at the time) were always identified by *Range*. The molbloc-L *Range* is the molbloc nominal full scale flow in Nitrogen (N<sub>2</sub>) at an operating pressure of 250 kPa. Actual molbloc ranges change with the molbloc pressure dependent calibration type and gas (see [Premium molbloc-L Calibrations](#)). Since mid-1999, in addition to nominal range, molbloc-L elements have been designated by size with a sizing code (see [Table 19](#)).

On molbloc EEPROMs, the molbloc is still identified by its nominal range rather than by its size. The identification of the molbloc displayed by , **<1molbloc>** identifies molbloc-L by both its nominal range and sizing code. molbloc-L size and range designation correspondence are given in [Table 19](#).

**Table 19. molbloc-L Size and Nominal Range Designations**

<b>molbloc Nominal Range Designation</b>	<b>molbloc-L SIZE Designation</b>
10 sccm	1E1
50 sccm	5E1
100 sccm	1E2
200 sccm	2E2
500 sccm	5E2
1 slm	1E3
5 slm	5E3
10 slm	1E4
30 slm	3E4
100 slm	1E5

molbloc-S elements are also identified by size designations, each of which relate to a specific molbloc-S KF value. molbloc-S flow ranges depend on calibration type and the pressure limitations of the application and molbox used. For information on the possible molbloc-S flow ranges with various operating pressures, see [Premium molbloc-S Calibrations are in Table 6.](#) molbloc-S size and KF value correspondence are given in [Table 20](#).

**Table 20. molbloc-S Size and Pressure to Flow Conversion Ratio (KF)**

<b>K<sub>F</sub> (sccm/kPa)</b>	<b>molbloc-S Size Designation</b>
10	1E1-S
20	2E1-S
50	5E1-S
100	1E2-S
200	2E2-S
500	5E2-S
1,000	1E3-S
2,000	2E3-S
5000	5E3-S
10000	1E4-S

## <2stab>

### Purpose

To change the stability limit that serves as the criterion for the flow Ready/Not Ready indication (see [Flow Ready/Not Ready Indication](#)).

### Principle

molbox2 continuously monitors the rate of change of flow through the molbloc to which it is connected and compares this rate to the stability limit to make a Ready/Not Ready determination (see [Flow Ready/Not Ready Indication](#)). The STABILITY function allows the stability limit to be adjusted by the user to increase or decrease the stability required for a Ready (<\*>) condition to occur.

#### Note

*The default stability limit is + 0.1 sccm/second (or equivalent in another flow unit). The stability limit value is automatically converted when the flow unit of measure is changed.*

*The stability limit is separate and different from the RATE DISPLAY function (see [<1Rate>](#) which allows the current rate of change of flow to be shown.*

### Operation

To adjust the stability limit push  <2stab>.

The display shows:

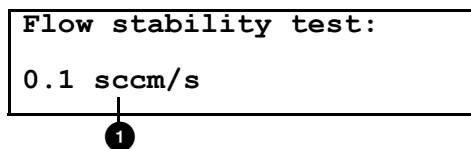



```
Flow stability test:
0.1 sccm/s
```

- ① - Entry field for setting the stability limit in the current flow unit of measure. Recalls the default stability limit or the last stability limit set.

Edit the stability limit setting as necessary. Push  to activate the stability limit for the range and returns to the current run screen.

#### Note

*The stability limit value is automatically converted when flow units of measure are changed.*

The  setting affects the resolution of the stability limit value. If the stability limit display does not have enough resolution to set the desired value, push  to adjust the resolution (see [\[RES\]](#)).

## <3ADJ>

### Purpose

To apply adder (FA) and multiplier (FM) coefficients to the flow measured by the molbox2.

### Principle

The ADJ function adjusts mass flow readings made by the molbox2. To do this, set an *adder* and a *multiplier*.

The *adder* (FA) and *multiplier* (FM) adjust the shown value of the flow through the molbloc as calculated by the molbox RFM following:

$$\text{corrected flow} = (\text{calculated flow} * FM) + FA$$

If a K factor is active (see [K]), the *adder* and *multiplier* are applied to the calculated flow before the K factor is applied.

### Using the Flow ADJ Function with molbloc-L to Handle a Gas Mixture

The flow ADJ function adjusts flow readings to measure a gas mixture if the molecular weight and relative content of each component gas is known. Note that this method does not take into account the true viscosity, compressibility, or critical flow coefficient factor of the gas mixture. The thermodynamic properties of only the highest concentration gas are used. Therefore, the uncertainty in the measured flow is increased and the method is best when the highest concentration gas is >90 % of the mixture.

To use this feature, set the molbox2  (see [GAS]) to the highest concentration gas, then adjust the flow *multiplier* by:

*molecular weight of the mix*

*molecular weight of the gas selected on the molbox*

For example, to adjust a gas mix that is 95 % Nitrogen (N<sub>2</sub>) and 5 % Oxygen (O<sub>2</sub>):

1. Calculate the molecular weight of the mix.

$$N_2 \text{ molecular weight} = 28.016$$

$$O_2 \text{ molecular weight} = 31.999$$

$$\text{Mix molecular weight} = (28.016 \times 0.95) + (31.999 \times 0.05) = 28.215$$

2. Select N<sub>2</sub>, the highest concentration gas, as the molbox2 gas.

3. Calculate:

$$\frac{\text{molecular weight of the mix}}{\text{molecular weight of the gas selected on the molbox}} = \frac{28.215}{28.016} = 1.0071$$

4. Set flow *multiplier* in ADJ function to 1.0071.

## Operation

To access the ADJ function, push , **<3adj>**. The display shows:

Adder: 0	sccm
Mult: 1.00000	

Edit the values as necessary. Push  to return to the MAIN run screen with the edited adder and multiplier values applied.

### Caution

**The *adder* is expressed in current flow units and is NOT automatically converted when flow units are changed. Adder values must be entered in the current flow units. The *multiplier* is dimensionless.**

**The flow *adder* and *multiplier* of the ADJ function, if different from 0 and 1, alter the flow readings made by the molbox2. The ADJ function is always ON with no indication on the run screen of the current *adder* and *multiplier* values and will be applied to the flow value of any attached molbloc. When you use *adders* and *multipliers*, great caution should be taken to ensure that they are entered and changed correctly and that they are 0 and 1 if no *adder* or *multiplier* effect is necessary.**

## <4A\_B>

### Purpose

To turn ON and OFF special molbox2 operating modes that use molbox2 channels A and B together.

### Principle

There are two A\_B modes. In both of these modes molbox automatically switches between the molblobs on its two channels and uses readings from both. The two A\_B modes are:



- **Additive mode (A+B) (see [A+B mode](#))**

The additive mode sums the flow on channels A and B. This mode uses two molblobs in parallel to measure flows greater than the maximum flow range of a single molbloc.

- **Ratiometric mode (A/B) (see [A/B Mode](#))**

The ratiometric mode determines the ratio of the flow through two molblobs. This mode provides a convenient, system controlled, method for comparing molblobs to determine the coherence between different ranges.

## General Operation (Aspects Common to Both A\_B Modes)

To access A\_B modes, push  **<4A\_B>** and select the necessary mode (**<1A+B>**, **<2A/B>**). Once you select the mode, molbox2 returns to the MAIN run screen with the selected mode active. An indication of the active A\_B mode will be in the lower right of the MAIN run screen when space is available. To cancel operation of an A\_B mode, push  (see [\[A/B\]](#)) and operation returns to normal single channel mode.

When in an A\_B mode, channel A is the dominant channel so the channel-specific functions applied (gas, flow unit, stability test, K factor) are those currently selected for channel A. Tare and leak check still apply to each channel individually. Purge automatically purges channel A and then channel B (see [\[TARE\]](#)).

When in an A\_B mode, the channel indicator LED switches between channels showing the channel that is currently active. The P&T function displays (see [\[P&T\]](#) ([Pressure and Temperature](#))) also switch as molbox2 switches from channel to channel to display values for the currently active channel.

In an A\_B mode, molbox2 reads on one channel until either a *Ready* reading is obtained or for up to 10 seconds, whichever comes first. If the last two single channel readings were *Ready*, the A+B or A/B result is shown as *Ready*. If one or both of the last two single channel readings was *Not Ready*, the A+B or A/B result is shown as *Not Ready* (see [Flow Ready/Not Ready Indication](#)).

### Note

*Set the molbox2 stability setting as low as is practical in any A\_B mode to allow for flow stabilization on each channel. To change the molbox stability setting, select , **<2stab>** (see [<2stab>](#)).*

*In A\_B mode operation, molbox2 may stay on one channel up to 10 seconds waiting for a Ready reading. The first valid reading after entering A\_B mode may require 20 seconds and subsequent readings up to 10 seconds.*

*You cannot operate A\_B modes when the active BPR mode is Auto due to internal valving conflicts. molbox2 denies access to the A\_B modes if the current BPR mode is Auto and will not allow the user to select Auto mode when an A\_B mode is active (see [<9BPR>](#)).*

*A+B and A\_B mode are supported only when molblobs of the same type are used. For example molbloc-S and molbloc-S. The option is not available for a molbloc-S and molbloc-L combination.*

## A+B mode

### Purpose

To operate two molblobs simultaneously on molbox2 channels A and B and obtain a flow rate which is the sum of the flow through the two molblobs.

## Principle

In A+B mode, molbox2 makes measurements on one channel and then the other channel. The flow rate shown is the sum of the two most recent channel readings, updated each time a channel reading completes. This allows two molblobs to be used together in parallel to measure flows greater than the range of a single molblob.

## Set Up

Best results with A+B mode are obtained when the two molblobs are mounted in parallel, symmetrically. Use a common regulator with as little tubing and fittings as possible between the point where flow is split upstream of the two molblobs and rejoined downstream. Standard hardware setups (molstics) for A+B operation are available from Fluke Calibration.

## Operation

To activate A+B mode, push , **<4A\_B>** and then select **<1A+B>**. molbox2 returns to the MAIN run screen in A+B mode.

The MAIN run screen in A+B mode shows:

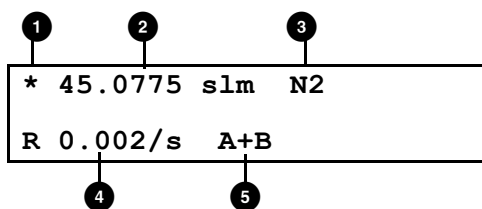

- ① - Ready/Not Ready indication.
- ② - Sum of channel A and channel B's two most recent flow rate readings and the unit of flow.
- ③ - The gas that is being flowed.
- ④ - Rate of change of flow for the A+B results in units of flow per second.
- ⑤ - Indication that A+B mode is active (if space is available).

The MFC run screens (if the molbox2 has the optional MFC control feature) are unchanged except that the top line indications are A+B flow.

## A/B Mode

### Purpose

To operate two molblobs simultaneously on molbox2 channels A and B and display the ratio of their flow rates.

## Principle

In A/B mode, molbox2 makes measurements on one channel and then the other channel. The individual flow rate measured by each channel shows as it is read and information on the ratio and disagreement between the two channels is also calculated and shown.

This function provides a convenient, system controlled, means of to compare two molblocs, for example to check the coherence of measurements made by different molblocs.

## Set Up

When you use A/B mode to compare two molblocs, the two molblocs are connected in series. The volume between the two should be minimized and the upstream pressure regulation should be as stable as possible to facilitate the establishment of the steady state flow condition that must exist for a valid comparison to be made. When you select the hardware setup to run an A/B mode comparison, it is important that the resulting setup allows each molbloc to operate under the correct pressure conditions for that molbloc calibration type. It helps to set the molbox2 stability setting as low as is practical in any A\_B mode to allow for flow stabilization on each channel. To change the molbox2 stability setting, select , **<2stab>** (see [<2stab>](#)).

### Note

*A/B operation is not recommended with 1E5 molblocs due to their low differential pressure range.*

## Operation

To activate A/B mode, push , **<4A\_B>** and then select **<2A/B>**. molbox2 returns to the MAIN run screen in A/B mode.

The MAIN run screen in A/B mode shows:

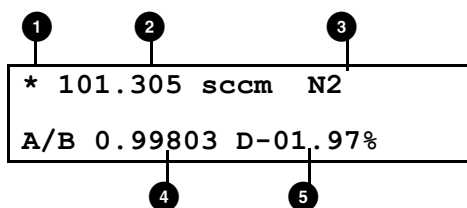

- ① - Ready/not ready indication.
- ② - Last flow measurement on currently-active channel with flow unit.
- ③ -The gas that is being flowed.
- ④ -The ratio of the two most recent channel readings (A/B).
- ⑤ - The difference in percent between the two most recent channel readings.

Though the optional MFC control functions are still active in A/B mode, the MFC run screens are not available.

*Note*

To return to single channel mode, use the A/B function to select either A or B molbloc.

## <5MFC>

### Purpose

To create, store and edit the MFC profiles used by the optional MFC control function (see [\[MFC\] \(Optional\)](#)).

*Note*

The MFC control function is an optional feature of molbox2. If this option was not ordered with the molbox2, the 1mfc function of the SETUP menu will not be active.

### Principle

MFC profiles are used by molbox2 to configure the MFC function. MFC profiles define the analog signal range of the MFC and the relationship between the analog signal range and the flow range of the MFC. This information allows molbox2 to operate with the correct signal for the current MFC and to convert the MFC analog signals to the corresponding flow or % FS values when necessary.

MFC profiles are set up with , <5MFC>. MFC profiles are stored by molbox2 under profile numbers. Use this profile number to select the MFC profile when the MFC function is activated with the MFC function key (see [\[MFC\] \(Optional\)](#)). Up to 26 MFC profiles can be defined and stored.

MFC profiles allow set up of the profiles of the MFCs typically calibrated by or used with molbox2 so that they can be conveniently recalled from a lookup table when needed.

MFC profiles #1 and #2 are factory profiles and cannot be edited. Profile #1 sets the MFC control option to work in Volts with no flow range specified. Profile #2 sets the MFC control option to work in milliamps with no flow range specified.

### Operation

To create or edit an MFC profile, push , <5MFC>.

Select the profile number to edit and push .

*Note*

MFC profiles #1 and #2 are factory default profiles for working with the MFC function directly in analog units without specifying MFC flow range or units. Profile #1 is 0 V to 5 V, profile #2 is 4 mA to 20 mA (see [\[MFC\] \(Optional\)](#) and <5MFC>).

The display shows:

```
Input type:
1voltage   2current
```

Select the analog signal type of the MFC and push .



Use the next screen to enter the full scale voltage or current. Enter the full scale voltage of current of the MFC and push . If the MFC signal selected was current (mA), you are also be prompted to enter the MFC 0 flow current output. The molbox2 MFC control function does not support mixed current/voltage MFCs.

The next selection specifies the flow units of measure for this MFC profile. See [\[UNIT\]](#) for an explanation of the unit selections.

After the flow unit of measure is selected, the display prompts for the range to be entered in the previously selected units. Enter the numerical value of full scale of the MFC in flow units.

```
Enter range
100.000 sccm
```

The next selection specifies whether the device is a mass flow meter that measures flow only (MFM) or a mass flow controller (MFC). Select **<1MFM>** if the device for this profile measures only, select **<2MFC>** if the device measures and controls flow.

Once the device type is selected, the edit is complete, and a prompt to edit the next profile # is shown. Push  to return to the MFC function. Push  again to return to the current run screen.

#### Note

To clear/reset all MFC profiles, except #1 and #2 factory default profiles, use  **<1reset>**, **<3mfc>**.

## <6REG>

### Purpose

To turn the ON and OFF the MFC control regulation mode, and to set the regulation period for regulation mode.

#### Note

The REGE function affects the molbox2 MFC control function. The MFC control function is an optional feature. If this option is not installed in the molbox2, the REG function of the SETUP menu is not active.

## Principle

Regulation mode allows an MFC to be used with molbloc/molbox to precisely set flows as measured by the molbloc/molbox. This feature allows an MFC to control flows to specific values as measured by the molbloc/molbox.

When the molbox2 MFC function is active, set points can be sent to the MFC. In normal operation, the set point entered is the set point signal sent to the MFC and that set point is held constant until a new set point is given. Use the molbloc/molbox to read the flow that results from that MFC setpoint.

Regulation mode allows a set point to be given in terms of the necessary flow through the molbloc as measured by the molbox2. In regulation mode, the molbox2 regularly readjusts the actual set point applied to the MFC as necessary to adjust flow to the necessary flow value through the molbloc. At each regulation cycle, the molbox2 corrects the set point to the MFC based on the difference between actual flow through the molbloc and the necessary flow. The regulation period sets the time interval between each regulation cycle.

### Note

*If there is a significant volume between the molbloc and the MFC, regulation is improved by increasing the regulation period.*

## Operation

To activate or deactivate regulation mode and to set the regulation period, push  **<6reg>**.

The display shows:

```
Regulation Period
(0 disables): 0
```

If 0 (zero) is entered, regulation mode is inactive. If a value >0 (zero) is entered, regulation mode activates and the regulation period value is entered in seconds.

Maximum regulation period:	99 seconds
Minimum period:	Single channel operation:2 seconds
A+B Mode:	10 seconds
Typical effective regulation period:	Single channel operation:5 seconds
A+B Mode:	20 seconds

When the regulation mode is active, **<R>** shows in the bottom right corner of the MAIN run screen (when space is available).

## <7FLOWU>

### Purpose

To customize the selection of flow units of measure that are available for selection from  (see [\[UNIT\]](#)).

### Principle/Operation

See [Customize FLOW Units Available Under The UNIT Function](#).

## <8PRESU>

### Purpose

To select/change the shown unit of measure on molbox2 pressure values.

### Operation

To set the unit of measure, push , **<8presU>**.

The display shows:

```
Pressure unit type:
1SI  2other  3user
```

Select the unit type, then select the unit. After the unit selection, operation returns to the run screen with the selected pressure unit of measure active.

The pressure units of measure available are listed in [Table 21](#).

**Table 21. Pressure Units of Measure Available**

<1SI>	<2Other>	<3User> <sup>[1]</sup>
<1Pa>	<1psi>	<1user>
<2kPa>	<2psf>	
<3mPa>	<3inHg>	
<4mbar>	<4inWa>	
<5bar>	<5kcm2>	
<6mmHg>		
<7mmWa>		
[1] User-defined unit		

*Note*

*The user unit is defined in terms of user units/Pa when the user unit is selected.*

*See [Pressure](#) for definition of the pressure unit conversions used by molbox2.*

## <9TEMPU>

### Purpose

To select the molbox2 unit of measure.

### Operation

To set the molbox2 unit of measure for temperature values, push , <9tempU>.

Select the necessary unit. After the unit selection, operation returns to the run screen with the selected temperature unit active.

### Note

See [Temperature](#) for definition of the temperature unit conversions used by molbox2.

## [SPECIAL]

### Purpose

Accesses a menu of functions and settings that are less common or not normally used in regular operation. These functions include:

- |            |  |
|------------|--|
| <1reset>   | Access and execute various reset options (see <a href="#">&lt;1reset&gt;</a> ).  |
| <2level>   | Set user-protection levels that restrict access to certain functions and edit the user password (see <a href="#">&lt;2level&gt;</a> ). |
| <3ul>      | Set upper pressure limit alarm (see <a href="#">&lt;3UL&gt;</a> ).   |
| <4cal>     | View and adjust the molbox2 pressure transducers, reference resistors, and MFC analog option (see <a href="#">&lt;4cal&gt;</a> ).      |
| <5prefs>   | Set display screen saver time, unit ID number, and date and time (see <a href="#">&lt;5Prefs&gt;</a> ).                                |
| <6remote>  | View and edit molbox2 COM port (RS232) and IEEE-488 interface settings (see <a href="#">&lt;6REMOTE&gt;</a> ).                         |
| <7drivers> | Control the ONOFF of molbox2 optional 12 V drivers (see <a href="#">&lt;7Drivers&gt;</a> ).  |
| <8head>    | Set the height for the pressure fluid head correction (see <a href="#">&lt;8Head&gt;</a> ).  |
| <9BPR>     | Set back pressure ratio (BPR) mode (molbloc-S operation only) (see <a href="#">&lt;9BPR&gt;</a> ).                                     |

## Operation

To access the SPECIAL menu, push  from the MAIN run screen.



The display shows:

```
1reset 2level 3ul
4cal 5prefs 6remote ↓
7drivers 8head 9BPR
```

Select the necessary function.

See [<1reset>](#) to [<9BPR>](#) for detailed SPECIAL function descriptions.

### Note

*Some screens (for example, the SPECIAL menu) go beyond the two lines provided by the display. This is indicated by a flashing down arrow in the second line of the display. Push  and  to move the cursor to access the lines that are NOT visible or directly enter the number of the hidden menu choice if you know it.*

## <1reset>

### Purpose

To reset various molbox2 settings to default or factory values.

### Principle

molbox2 stores its user-definable settings in non-volatile memory. The reset menu allows selective or complete reset of these settings to factory defaults. Reset clears settings that the user may have made, and should be used only to restore the molbox2 to a known state. molbox2 goes through its reboot routine after any type of reset is executed.

## Operation

To access the reset choices, push  **<1reset>**.

The display shows:

```
1sets 2units 3mfc
4cal 5all
```

Select the necessary reset. After confirmation, the reset occurs. A reset puts the molbox2 through its start up routine as if power had been turned OFF and back ON. See [<1sets>](#) through [<5all>](#) for detailed information on the specific reset choices.

*Note*

*RESET functions change user settings that affect flow measurement. If not used properly, a RESET can cause out of tolerance measurements. RESET functions should only be used by qualified personnel with reference to this manual for information on the RESET functions.*

[<1sets>](#)

**Purpose/Operation**

To access Reset - Sets, push , **<1reset>**, **<1sets>**.

Reset - Sets clears and sets to default the user settings for various measurements. These include:

- Flow unit of measure to sccm (see [\[UNIT\]](#)).
- Pressure unit of measure to kPa (see [<8PRESU>](#)).
- Temperature unit of measure to °C (see [<9TEMPU>](#)).
- Gas type to N2 (see [\[GAS\]](#)).
- Stability criterion to 0.1 sccm (see [<2stab>](#)).
- K factor to 1 (see [\[K\]](#)).
- DISPLAY function to Rate (see [<1Rate>](#)).
- RPT Tare value to 0 (see [<1tare>](#)).
- Tare to upstream pressure (see [<1tare>](#)).
- Flow adder to 0 and flow multiplier to 1 (see [<3ADJ>](#)).
- Resolution to 0.001 % (see [\[RES\]](#)).
- BPR mode to Auto (see [<9BPR>](#))

[<2units>](#)

**Purpose/Operation**

To access Reset - Units, push , **<1reset>**, **<2units>**.

- Reset - Units clears and sets to default all UNIT OF MEASURE functions. These include:
- Six flow units of measure selectable from  to defaults (see [\[UNIT\]](#)).
- Flow unit of measure to sccm (see [\[UNIT\]](#)).
- Reference temperature for uxxx units of measure to 0 °C (see [Volumetrically Based Mass Flow Units at Various Reference Temperatures \(UXXX\)](#)).

- Volume flow unit of measure conditions to molbloc for temperature and standard atmospheric pressure for pressure (see [Volume Flow Units \(vIm\)](#)).
- Pressure unit of measure to kPa (see [<8PRESU>](#)).
- User pressure unit coefficient to 1.00/Pa (see [<8PRESU>](#)).
- Temperature unit of measure to °C (see [<9TEMPU>](#)).

[<3MFC>](#)

### **Purpose/Operation**

To access Reset - MFC, push , **<1reset>**, **<3MFC>**.

Reset - MFC clears and sets to default all functions associated with the optional analog MFC control. These include:

- Set MFC channel to 0 (inactive) (see [\[MFC\] \(Optional\)](#)).
- Set regulation mode to OFF (see [<6REG>](#)).
- Set MFC profile to 1 (see [MFC Profiles](#)).
- Clear/delete user defined MFC profiles (see [<5MFC>](#)).

[<4cal>](#)

### **Purpose/Operation**

#### **Caution**

**Use special caution with this reset as critical calibration data may be altered.**

To access Reset - Cal, push , **<1reset>**, **<4cal>**.

Reset - Cal clears and sets to default the user calibration coefficients for molbox2 Reference Pressure Transducers (RPTs) (see [Calibration Of Reference Pressure Transducers \(RPTS\)](#)). This includes:

- Upstream and downstream absolute RPTs:
 

Adder	0
Multiplier:	1
Calibration Date:	19980101

#### *Note*

*Reset - Cal has NO effect on the reference resistance values used to calibrate molbox2 internal ohmic measurement system (see [OHMIC Measurement \[Temperature\] System Verification](#)) or on the calibration coefficients for the optional MFC control function (see [\[MFC\] \(Optional\)](#)).*

<5all>

### **Purpose/Operation**

Returns molbox2 to the original, as delivered factory condition. Performs the SETS, UNITS, CAL, and MFC RESET functions and resets all other settable values to defaults. This includes communications port settings.

To access Reset - All, push , <1reset>, <5all>.

### **⚠ Caution**

**Use special caution with this reset as critical calibration data may be altered.**

<2level>

### **Purpose**

Sets user protection levels that restrict access to certain functions and to edit the password required for changing user levels.

### **Principle**

The front panel provides access to all molbox2 user defined data, settings, and functions including calibration data. Inadvertent, uninformed, or unauthorized altering or deleting of data, settings and functions could require extensive reconfiguration by the user and might cause invalid readings. For these reasons, restrict access to certain functions.

Access to changing security levels can be left open, or be protected by a password so that security levels can be used as a convenient way to avoid accidental changing of data or as a secured means of preventing tampering with molbox2 settings.

### **Security Levels**

The security levels are structured to support typical operating environments:

- |               |   |
|---------------|---|
| <b>None</b>   | This level is for use only by the system manager and/or calibration facility. It allows access and editing in all areas including critical metrological information and other settings that affect measurement integrity.   |
| <b>Low</b>    | Low security protects the specific metrological information and SYSTEM DIAGNOSTIC AND MAINTENANCE functions of the system against accidental alteration. It is intended for an advanced operator who does many different tasks. Low security is the default user level setting. |
| <b>Medium</b> | Medium security protects specific metrological information in the system and to assure that the molbox2 is operated with consistent operational parameters.   |
| <b>High</b>   | High security protects all operating parameters. High security minimizes operator choices (for example, to do repeated identical tests under consistent conditions).  |

**⚠ Caution**



















**molbox2 is delivered with the security level set to low to avoid inadvertent alterations of critical internal settings but with unrestricted access to changing security level setting. Fluke Calibration recommends that the low security level be maintained at all times and password protection be implemented if control over setting of security levels is necessary.**

**If there is a risk of unauthorized changes to the security level, changing authority should be password protected (see Operation in this section).**























**The High security level disables remote communications and returns an error message (*ERROR*) to all remote commands. All other security levels have NO effect on remote communications.**

The security levels are structured to support typical levels of operation. Specifically, the key strokes marked by X in [Table 22](#) are restricted for that level.

**Table 22. Security Levels**

Keys	Low	Medium	High
			X
			X
			X
 (change temperature/pressure conditions)		X	X
 (access menu)			X
 , <1tare>, <select tare pressure>		X	X
 , <2purge> change purge time		X	X
 , <4AutoZ>, <4run>		X	X
			X
			X
 (change times/target)		X	X
			X
		X	X
		X	X
 (access to menu)			X
 , <1molbloc>			X
 , <2stab>		X	X
 , <3adj>	X	X	X

**Table 22. Security Levels (cont.)**

Keys	Low	Medium	High
 <b>&lt;4A_B&gt;</b>		X	X
 <b>&lt;5MFC&gt;</b>		X	X
 <b>&lt;6mode&gt;</b>		X	X
 <b>&lt;7flowU&gt;</b>		X	X
 <b>&lt;8presU&gt;</b>		X	X
 <b>&lt;9tempU&gt;</b>		X	X
 <b>&lt;1reset&gt;</b>		X	X
 <b>&lt;1reset&gt;, &lt;1sets&gt;</b>		X	X
 <b>&lt;1reset&gt;, &lt;2units&gt;</b>		X	X
 <b>&lt;1reset&gt;, &lt;3MFC&gt;</b>	X	X	X
 <b>&lt;1reset&gt;, &lt;4cal&gt;</b>	X	X	X
 <b>&lt;1reset&gt;, &lt;5all&gt;</b>	X	X	X
 <b>&lt;3UL&gt;</b>			X
 <b>&lt;3UL&gt;</b> (change setting)		X	X
 <b>&lt;4cal&gt;</b>		X	X
 <b>&lt;4cal&gt;, &lt;any 3edit&gt;</b>	X	X	X
 <b>&lt;5prefs&gt;</b>		X	X
 <b>&lt;5prefs&gt;, &lt;1ScrSvr&gt;</b>		X	X
 <b>&lt;5prefs&gt;, &lt;2ID&gt;, &lt;2edit&gt;</b>	X	X	X
 <b>&lt;5prefs&gt;, &lt;3time&gt;</b> (make changes)	X	X	X
 <b>&lt;6remote&gt;</b>			X
 <b>&lt;6remote&gt;</b> (changes settings)		X	X
 <b>&lt;7drivers&gt;</b>		X	X
Remote communications disabled			X

## Operation

### Note

*molbox2 is delivered with NO active password so access to the User Level menu is open. The user level is set to <1Low>. User levels can be changed freely until a password has been created. RESET functions (see <1reset>) do not affect the password setting.*

To access the USER LEVEL function, push  <2level>.

If NO password yet exists or if the correct password has been entered, the display shows:

```
1change user level
3edit password
```

Selecting <1change user level> brings up the restriction menu:

```
Restriction: 1none
2low 3medium 4high
```

Select the necessary restriction level, or push  to return to the current run screen.

Select <2edit password> to show the user password and allow it to be edited. Passwords can be up to six numbers in length and cannot start with a zero.

```
Password: pppppp
0 disables password
```

If 0 is entered as the password value, then the password is made inactive and a password will NOT be required to access the user level menu. This is the factory default with a security level of <2low>.

### Caution

**Once a password has been entered, the user level cannot be changed without reentering the password.**

If there is an active password, the molbox2 password entry screen appears.

The user must enter the user-defined password or the factory-secondary password to proceed. When a password is entered correctly, operation proceeds to the **<1change user level 2edit password>** screen.

<b>RFM</b>	<b>SN</b>	<b>nnn-xx</b>
<b>Password:</b>	<b>pppppp</b>	

The first field, **<nnnn>**, is the serial number of the molbox2, followed by a second field, **<xx>**, that counts the number of times that a secondary password has been used. The second field increments each time a secondary password is used. The third field, **<pppppp>**, is for normal password entry.

The factory secondary password is available in case the user password has been misplaced or forgotten. A factory secondary password can be obtained by contacting a Fluke Calibration authorized service provider (see the warranty at the start of this manual). The factory secondary password is different for each molbox2 and changes each time it is used.

### **<3UL>**

#### **Purpose**

Sets an upper pressure limit above which molbox2 produces a warning, interrupt operation and isolate its internal pressure transducers.

#### **Principle**

molbox2 contains two, high-precision reference pressure transducers (RPTs). These can be fatally damaged by large overpressures. The UL function uses molbox2 internal capabilities to attempt to protect the RPTs against overpressure. molbox2 continuously monitors the pressure read by the RPTs. When the pressure passes the level set by the UL function, molbox2 warns by sounding an audible alarm. Beyond the UL limit there is an overpressure limit, which is not user selectable. If the pressure reaches the overpressure limit, molbox2 uses its internal valves to isolate the RPTs.

#### **Operation**

To access the Upper Limit (UL) function, push  **<3ul>**. The display shows:

<b>Transducer Max Pres:</b>
<b>600.000 kPaa</b>

The indication is of the current upper limit setting in the current pressure unit of measure. To specify a different pressure unit of measure, use , **<8presU>** (see [<8PRESU>](#)).



To change the upper limit, enter the value desired (see max UL limits below) and push . The display returns to the MAIN run screen with the new upper limit in effect.

The maximum upper limit settings, which are also the default values, are 5 % above the molbox2 maximum operating pressure ranges. For the molbox2 models, the max UL values are specifically:

- For molbox2 **A350K**: 315 kPa absolute (45 psia)
- For molbox2 **A700K**: 630 kPa absolute (91 psia)
- For molbox2-S **A1.4K**: 1470 kPa absolute (213 psia)
- For molbox2-S **A2M**: 2100 kPa absolute (304 psia)

The molbox2 overpressure limits, which cannot be edited, are:

- For molbox2 **A350K**: 330 kPa absolute (48 psia)
- For molbox2 **A700K**: 660 kPa absolute (96 psia)
- For molbox2-S **A1.4K**: 1540 kPa absolute (223 psia)
- For molbox2-S **A2M**: 2200 kPa absolute (319 psia)

If the overpressure limit is exceeded, all molbox2 internal valves close and normal operation is interrupted. Reestablish normal operation by turning the molbox2 power OFF and back ON or push . Be sure to correct the situation that led to the overpressure condition prior to rebooting molbox2 or push . See [Upper Limit Alarm and Sequence](#) and [Reference Pressure Transducer \(RPT\) Overpressure](#) for additional details.

*Note*

*UL is molbloc channel specific. There are separate UL settings for molbloc channel A and channel B operation.*

### Upper Limit Alarm and Sequence

When the pressure reaches the upper limit, molbox2 continues normal operation but sounds an audible alarm. The alarm ceases if the pressure is decreased below the upper limit.

When pressure reaches the overpressure limit, all molbox2 internal valves close, normal operation ceases, and the display shows:

610.250 kPa 601.780  
OVERP! CHK & PWR DWN

The top line indicates the current pressure measurement of the upstream (left) and downstream (right) RPTs. The bottom line is the over pressure warning. Pressure indications that are grossly out of scale generally indicate that the RPT(s) have been fatally over pressured.

Other menus can be observed but the MAIN run screen can not be accessed and no molbox2 internal valves can be operated. To return the molbox2 to normal operation, it must be turned OFF and back ON or push  from the overpressure screen. When molbox2 normal operation is reestablished, its isolation valves will open. Be sure the situation that led to the overpressure condition is corrected before attempting to reestablish normal operation.

#### Note

*The upper limit and overpressure functions use the molbox2 features to the extent possible to protect the molbox2 reference pressure transducer (RPTs) against overpressure. The system is not failsafe and an overpressure that can cause fatal damage to the RPTs can still occur. Ultimately, protection of the RPTs is the responsibility of the user. RPTs damaged by overpressure are not covered under the product warranty.*

*molbox2 continuously monitors for maximum pressure. Whenever the overpressure limit is exceeded, the pressure value reached, time and date are logged to a privileged location. This information can be of use to determine the events that led to an overpressure situation.*

#### <4cal>

Calibrates and adjusts the molbox2 reference pressure transducers, ohmic measurement system, optional MFC control function, and the calibrated molbloc flow.

The CALIBRATION functions are considered part of molbox2 maintenance and are therefore covered in the maintenance section of this manual (see [Maintenance, Adjustments, and Calibration](#)).

#### <5Prefs>

##### Purpose

Accesses a menu of molbox2 internal operational preferences and functions. These include:

**<1ScrSvr>** View and change the SCREEN SAVER function (see [<1ScrSVR>](#)).

**<2ID>** View and edit the molbox2 user ID (see [<3ID>](#)).

**<3time>** View and edit the internal time and date settings (see [<3Time>](#)).

##### Operation

To access the PREFS menu, push , **<5prefs>**.

Select the necessary function.

## <1ScrSVR>

### Purpose

Adjusts the time setting of the molbox2 SCREEN SAVER function.

molbox2 has a SCREEN SAVER function which causes the display to dim after a key is NOT pushed for a certain amount of time. The default screen saver time activates the screen saver after 10 minutes. The screen saver activation time can be adjusted by the user or screen saving can be completely eliminated.

### Operation

To access the SCREEN SAVER function, push , **<5prefs>**, **<1ScrSav>**. Edit the time, in minutes, after which the screen saver activates to dim the screen. Set zero to eliminate the SCREEN SAVER function.

#### Note

*Set the screen saver time to zero to eliminate the SCREEN SAVER function so that the display permanently remains at full brightness.*

## <3ID>

### Purpose

To view or edit the user ID and view the Product serial number.

### Principle





molbox2 has a factory-programmed serial number that is included on the Product back panel and can be viewed in the introductory screen.

molbox2 also allows the user to store a unique, twelve character, alpha numeric ID number. This feature is frequently used to assign an organizational control ID (for example, an asset number, tool number, standard number). The ID function allows the ID number to be viewed and edited. It also displays the molbox2 factory serial number.

### Operation

To access the ID function:

1. Push , **<5prefs>**, **<2ID>**.
2. Select **<1view>** to view the current ID.
3. Select **<2edit>** to edit the ID.

The ID has twelve characters. When the edit screen is opened, the cursor is on the first character. Enter numerical values from the keypad. In addition, use  and  to toggle through a list of available alpha numeric characters. Holding the key slews through the characters. Character order going up () is: blank space, symbols, lower case letters, upper case letters, numbers. After you select a character, push  to activate it and move to the next character field.

When a character is selected, the cursor moves to the next character. To leave a blank character, push  with the field for that character blank. Use this for the trailing characters if the ID entered is less than twelve characters.

After the last of the twelve characters has been entered, the **<Save ID?>** option is offered. Select **<1no>** to return to the ID edit screen. Select **<2yes>** to save the edited ID.

*Note*

*You can also set the ID remotely from a computer (see [molbox2 commands, ID command](#)). The ID cannot be cleared or reset by any RESET functions (see [<1reset>](#)).*

### <3Time>

#### **Purpose**

To view and edit the internal time and date settings.

#### **Operation**

To access the TIME function, push , **<5prefs>**, **<3time>**. The display shows:

<pre>Edit: 1time 2date 08:32:11 am 19980101</pre>
---

Select **<1time>** to edit the time. Edit hours, then minutes, then am/pm. Push  at each entry. Seconds go to zero when minutes are entered. This can be used to synchronize the time with a time standard.

Select **<2date>** to edit the date. The date must be specified in YYYYMMDD format.

*Note*

*The molbox2 date and time are set to United States Mountain Standard Time in the final test and inspection process at the factory. Use the TIME and DATE functions to set your local time and date*

### <6REMOTE>

#### **Purpose**

Configures the molbox2 COM1, COM2 and IEEE-488 communication ports. Tests COM1 and COM2 communications.

#### **Principle**

The molbox2 has two RS232 communications ports, COM1 and COM2, and a single IEEE-488 port. COM1 and the IEEE-488 port are to communicate with a host computer (see [Overview](#)). COM2 is reserved for pass through communications with an external device, (for example, a multimeter, second molbox, or MFC controller). These ports can be set up from the molbox2 front panel.

molbox2 provides a self-test for its RS232 communication ports. The self-test allows verification that the molbox2 RS232 ports (COM1 and COM2) are operating properly and that a valid interface cable is used.

### Operation

Accesses the communication port configurations, push , **<6remote>**. Select **<1COM1>**, **<2COM2>**, or **<3IEEE-488>** to view and/or edit their settings.

Accesses the RS232 self-test, push , **<6remote>**, **<4RS232test>**.

### COM1 and COM2

The COMx port settings are adjustable. The settings are baud rate, parity, data bits, and stop bits. The available options are listed in [Table 23](#).

**Table 23. COM1 and COM2 Available Settings**

BAUD RATE	300, 600, 1 200, 2 400, 4 800, 9 600, 19 200
PARITY	NONE, ODD or EVEN
DATA BITS	7 or 8
STOP BITS	1 or 2

The default COMx settings are 2400, E, 7,1 for both COM ports.

The molbox2 appends a carriage return (**<CR>**) and a line feed (**<LF>**) to all messages that are sent out of the COM1 port to the host. It looks for a carriage return to terminate incoming messages and ignores line feeds. The user must wait for a reply to each message sent to the molbox2 before they send another message to it (see [RS232 Interface](#)).

### IEEE-488

The IEEE-488 port address can be defined from 1 to 31. The default address is 10.



The molbox2 sends a line feed (**<LF>**) and asserts the EOI line at the end of all transmitted messages. It looks for a line feed and/or assertion of the EOI line to terminate incoming messages (see [IEEE-488 \(GPIB\)](#)).

### RS232 Self-Test

The RS232 self-test checked the molbox2 COM ports and the interface cable independently of an external device or computer.

If difficulties arise during communication with molbox2 from a host computer with RS232, the RS232 self test helps to establish that the molbox2 COM1 port you are trying to communicate with and the interface cable in use are good.

To run a self test of the RS232 ports (COM1 and COM2):

1. Push , **<6remote>**, **<4RS232test>**. The display prompts to connect COM1 to COM2 with a standard pin to pin DB 9F to DB-9M RS232 cable (see [COM1](#)).
2. Once the cable is installed, push  to run the self-test. The test first executes in the COM1 COM2 direction and then in the COM2 COM1 direction.

If the COM1 COM2 test passes: **<PASSED>** shows briefly and the test proceeds to COM2 COM1.

If COM2 COM1 passes: **<PASSED>** shows briefly followed by the conclusion: **<molbox2 RS232 test has PASSED>**.

3. If a test fails: Execution is suspended until you push .

#### Note

*The molbox2 RS232 test can fail for these reasons:*

*The RS232 cable is incorrect (see [COM1](#) for information on the correct cable).*

*COM1 and COM2 do NOT have the same serial communications settings and therefore cannot communicate together (see [COM1 and COM2](#) to set the COM ports).*

*COM1 or COM2 is defective.*

Failed communications is usually a due to a cable or incorrect RS232 interface settings. Make sure that these are correct before you conclude that a COM port is defective.

## <7Drivers>

### Purpose

To control the output signals of molbox2 8 channel, 12 V external drivers.

#### Note

*The <3drivers> function is an optional feature of molbox2. If this option was not ordered with the Product, the operation of <3drivers> will have no effect.*

### Principle

molbox2 external drivers are available to drive peripheral equipment in a molbox2 system (for example, manifolding valves for selecting gas supply to the molbloc or automatically directing flow to molbloc channel A or B). The driver electrical connections are available from a rear panel connector (see [Valve Drivers](#) for driver specifications and pin outs).

### Operation

Accesses the driver control function, push , **<7drivers>**.

The display shows:

<b>External Drivers: 1</b>							
<b>2</b>	<b>3</b>	<b>4</b>	<b>5</b>	<b>6</b>	<b>7</b>	<b>8</b>	

Push the numerical key driver number to turn that driver ON and OFF with either a momentary or a toggled response. An active driver is indicated by **<\*>** that immediately follows the driver number. Push  while in the External Drivers menu causes a menu to appear that allows selection of whether the driver actuation by selecting the driver number will be **<1momentary>** or **<2toggle>**.

## <8Head>

### Purpose

To add or subtract a pressure fluid head correction to the pressure measured by the molbox2 reference pressure transducers in order to predict the pressure at height the height of the molbloc when the molbloc is at a level other than the molbox2 reference level.

### Principle

molbox2 measures absolute and differential pressure in molbloc flow elements. The molbox2 reference pressure transducers (RPTs) are calibrated with the height of the rear panel pressure quick connectors as the pressure reference level. Sometimes, when a user does a calibration or test, the molbloc is at a different height than the molbox2 pressure reference level. This difference in height, frequently called head, can cause a significant difference between the pressure measured by the molbox2 at its reference level and the pressure actually present at the molbloc at a different height. In this case, make a head correction to the pressure measured by the molbox2 to predict the pressure actually applied at a different height.

molbox2 calculates head pressures for all the gases it supports (see [\[GAS\]](#)), over its working pressure range. The HEAD function allows the difference in height between the molbox2 and the molbloc to be specified and causes the resulting head pressure to be added to the pressure measured at the molbox2 rear panel quick connectors.

Use , **<8head>**, to specify the height difference between the molbox2 rear panel quick connectors and another height. Enter a height of zero turns the function off.

### Note

*Use of the HEAD function to assure in tolerance measurements is most important when you use molbloc-S at high pressures. Specifying the head height within  $\pm 3$  in. (7.5 cm) is adequate to assure that, even in the worst case, the uncertainty on the head correction will be insignificant relative to the tolerance of the measurement.*

### Operation

Accesses the HEAD function, push , **<8head>**.

The display shows:

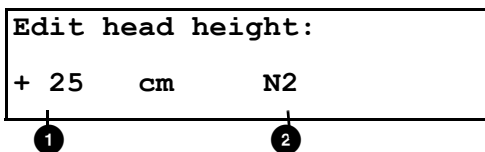

- ① - Entry field for head height.
- ② - Current molbox2 gas selection.

Edit the head height to the necessary value. Push **ENTER** to return to the run screen with the new head correction active. Push **ESC** to return with no changes.

*Note*

*The reference height of the molbox2 pressure measurement is the middle of the molbox2 rear panel pressure quick connectors. The head height should be entered as a positive value if the molbloc is higher than the molbox2 and negative if it is lower. See [Figure 11](#).*

**Figure 11. Reference Level**

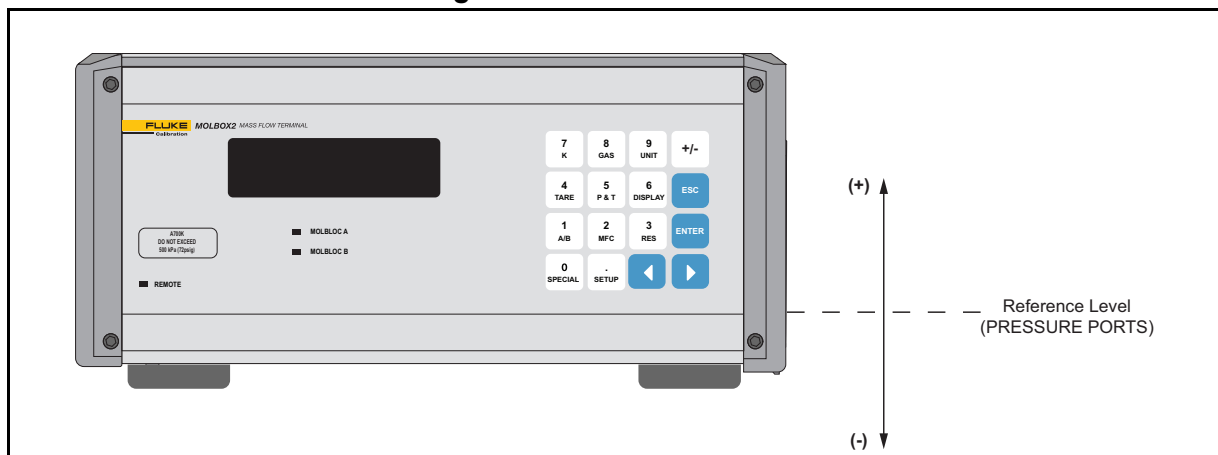

*Note*

*The HEAD function is NOT channel specific. The HEAD height setting and ON or OFF status remains the same as molbloc channels are changed.*

*As a head correction is applied, it is indicated by **<h>** to the right of the pressure unit in the **5 P&T** screen (see [\[P&T\] \(Pressure and Temperature\)](#)). When the head correction is zero, the **<h>** is not shown.*

*The head function is automatically disabled when running AutoZ and in the calibration run screen (see [View RPT outputs](#)).*

## <9BPR>

### Purpose

Selects the molbox2 BPR (back pressure ratio) measurement mode in molbloc-S operation. The molbox2-S BPR measurement mode is always on and there is no option to turn it off or use the auto selection option described below.

### Principle

When molbloc-S elements are used with molbox2, the RPT which is normally used to read molbloc downstream pressure can be pneumatically connected to either the molbloc-S nozzle upstream or downstream pressure, by molbox2 internal valving. The two RPTs are used simultaneously upstream when possible to minimize the uncertainty on molbloc-S upstream pressure measurement by averaging the two RPT readings. The upstream absolute pressure is the most critical measurement for calculation of the flow through molbloc-S.

Measurement of molbloc-S downstream pressure is only necessary to monitor the BPR (molbloc back pressure ratio). The value of BPR indicates whether the flow through the molbloc-S has achieved the necessary critical flow condition (see [molbloc-S BPR Limits](#)).

When the molbox2 internal valves are positioned to connect one RPT upstream and the other downstream of the nozzle to determine BPR, the valve state is referred to as BPR ON (see [Figure 12](#)).

**Figure 12. molbox2 Internal Pneumatic Schematic -molbloc-S Operation, Channel A, BPR**

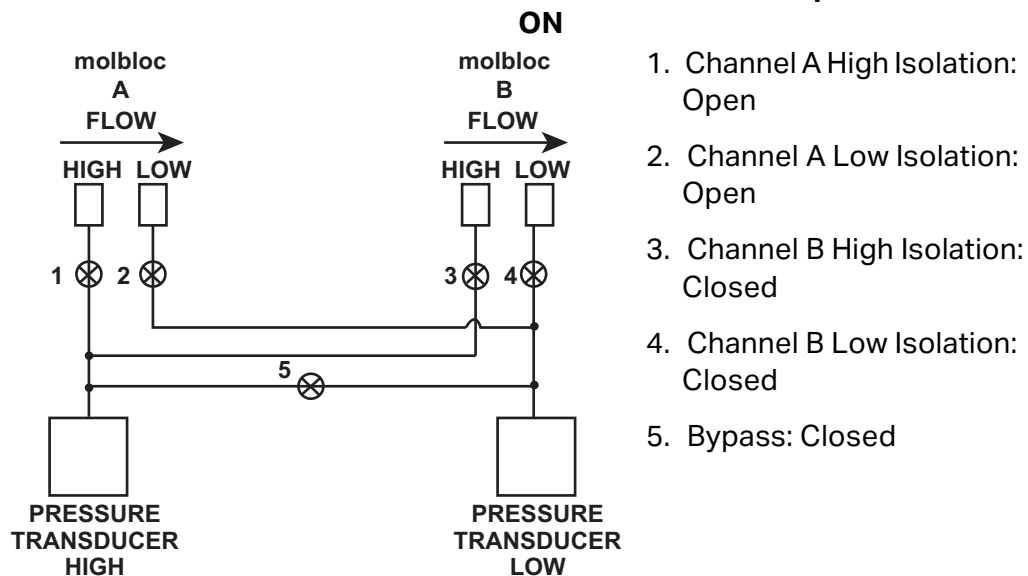

When the molbox2 internal valves are positioned to allow both RPTs to measure the molbloc-S upstream pressure, the valve state is referred to as BPR OFF (see [Figure 13](#)).

**Figure 13. molbox2 Internal Pneumatic Schematic - molbloc-S Operation, Channel A, BPR OFF**

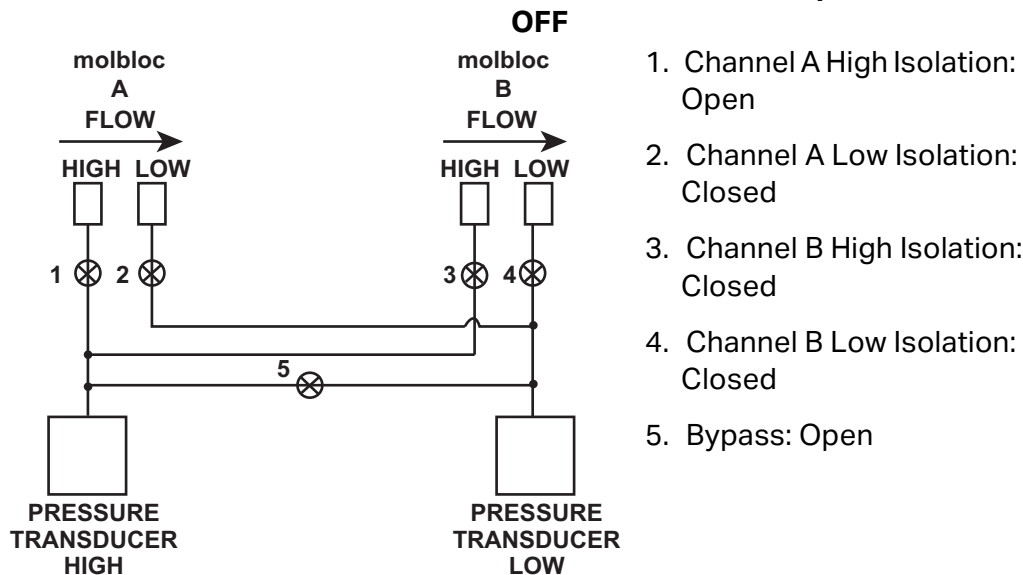

Ideally, the user can monitor the BPR with BPR ON while setting flows and pressures, and once the flow is established, uncertainties can be minimized by turning BPR OFF gaining the benefit of using both RPTs upstream. As an alternate to operator switching between BPR ON and BPR OFF, molbox2 has a BPR mode called Auto that uses on-board logic to determine when to turn BPR ON and OFF. In BPR Auto mode, the molbox uses cues based on flow and pressure changes, stability, and proximity to the Reynolds number-based BPR limits to determine when to switch between the BPR ON and BPR OFF valve states (see [9BPR](#)). Auto is the default BPR mode and is considered the normal mode for manual molbloc-S/molbox2 use.

For users who prefer to avoid automatic valving, there are two other BPR modes. BPR OFF mode keeps the molbox in the BPR OFF valve state at all times. BPR ON keeps the molbox in the BPR ON valve state at all times. BPR OFF mode should be used with caution, as it provides no monitoring of BPR to ensure that molbloc-S measurements are valid.

*Note*

*Fluke Calibration recommends to set BPR to ON.*

*When molbox2 is used in BPR OFF mode, molbox cannot measure the molbloc-S downstream pressure and provides no monitoring or indication of the BPR. molbox2 cannot warn the user when the flow through molbloc-S is not critical and flow measurements are not valid. For example, when the molbloc is at rest in BPR OFF mode, and atmospheric pressure is applied to both the upstream and downstream side of molbloc-S, the molbox2 indicates a false flow rate approximately equal to the molbloc-S KF value times the value of atmospheric pressure in kPa. If BPR OFF mode is used, the user must make sure that a sufficiently low BPR is maintained while making molbloc-S flow measurements (see [molbloc-S BPR Limits](#)). The 4 **TARE** [5BPR](#) function can be used for quick BPR checks (see [5BPR](#) (molbloc-S Operation Only)).*

## Operation

Accesses the BPR mode menu, push , **<9BPR>**.

The display shows:

```
BPR mode :
1BPRoff 2BPRon 3Auto
```

On a molbox2-S, BPR is always on. The menu does not provide a selection.

The display shows:

```
BPR mode :
BPR ON
```

Making a BPR mode selection, activates the selected BPR mode and returns to the previous RUN screen. Push  returns to the previous RUN screen without changing the BPR mode.

Select **<1BPRoff>** to cause the molbox2 internal valves to immediately switch to the BPR OFF valve state (see [Figure 12](#)) and remain there until the user changes the BPR mode or activates a function which causes a valve change (such as the , **<5BPR>** function, see [<5BPR> \(molbloc-S Operation Only\)](#)). In BPR OFF mode, the flow is calculated from the average of the two RPT pressure readings and the RPT pressures shown in the P&T pressure screen are adjusted using the dynamic tare feature, so both pressures are displayed equal to the average value (see [molbloc-L and molbloc-S Operation](#) and [\[P&T\] \(Pressure and Temperature\)](#)).

Select **<2BPRon>** to cause the molbox2 internal valves to immediately switch to the BPR ON valve state (see [Figure 10](#)), and remain there until the user changes the BPR mode or activates a function which causes a valve change. In BPR ON mode, flow is calculated from the upstream RPT measurement only. In BPR ON mode, there is no tare applied to the RPT readings at any time.

Selection of **<3Auto>** does not necessarily immediately change the BPR mode. Depending on the current BPR mode, BPR mode changes occur as follows:

### In Auto mode, in the BPR ON valve state:

molbox2 monitors the BPR value directly. If the BPR is safely below the BPR limit (calculated from empirical testing of molbloc-S choking ratios, see [molbloc-S BPR Limits](#)), then, once the flow is stable within 0.5 % of reading for 3 seconds, molbox2 switches to BPR OFF valve state and begins live averaging of the RPT pressure values.

**In Auto mode, in the BPR OFF valve state:**

molbox2 cannot monitor BPR, but based on the proximity of the most recently measured BPR to the calculated BPR limit, if the current flow value changes enough that it is likely that the BPR is approaching the limit, molbox2 switches to BPR ON valve state to check BPR directly. It is highly unlikely that valve switching will occur during critical flow measurements because, typically, high precision flow measurements are not made when flow is changing.

In Auto mode, when the valves are in BPR OFF state, flow is calculated from the average of the two RPT pressure readings as in BPR OFF mode. When the molbox2 valves switch to the BPR ON valve state in Auto mode, the tare can no longer be dynamically calculated because the two RPTs are not measuring the same pressure. The most recent tare that was automatically calculated during the BPR OFF valve state is used to correct the pressures used and shown in Auto mode until the valves return to the BPR OFF state again. This assures that flow measurements remain as consistent as possible during Auto mode valve switching and that the tare value that is most likely to be correct is used at all times.

*Note*

*It is possible to change the BPR mode by remote communication with molbox2 and also to disable molbox2 valve control and switching while in any BPR mode (see [molbox2 commands](#)).*



*It is not possible to operate A\_B modes when the active BPR mode is Auto due to internal valving conflicts. molbox2 denies access to the A\_B modes if the current BPR mode is Auto and does not allow the user to select Auto mode when an A\_B mode is active (see <[4A\\_B](#)>).*

## Remote Operation

### Overview

Most of the molbox2 front panel functions can also be executed by commands from a remote computer. The host computer can communicate with the molbox2 with the molbox2 COM1 RS232 port or the IEEE-488 port. The command syntax is the same for either port except when you use the IEEE STD. 488.2 Common commands.

### Interfacing

Sends any command to the molbox2 to put it into a *soft* remote mode. The remote indicator in the lower right corner of the molbox2 front panel is illuminated in remote mode. The indicator also flickers when remote communication occurs. The menus usually accessed from the front panel are locked-out while in remote mode. Push  to return the molbox2 to local operation unless the *REMOTE* command was sent to the unit. The *REMOTE* command locks out keypad operation until the *LOCAL* command is sent. In either level of remote mode,  still responds to allow the user to change the data being viewed on the molbox2 main run display.

Most remote commands return a reply within 500 ms. You must wait for this reply before you issue another command to the molbox2. This ensures that the molbox2 has completed the command. An exception to this is the use of any of the IEEE STD. 488.2 common commands (see [IEEE Std. 488.2 Common and Status Commands](#)) through the IEEE-488 interface (common commands all start with an asterisk, "\*"). The common commands only generate a reply with the COM1 port or if the query form of the common command is used (command followed by a "?").

These commands take more than, 500 ms to reply:

<b>ALLR, DP, FR, PR, RATE, SR, TARE</b>	Up to 2 seconds to allow a new measurement
<b>GAS</b>	Up to 5 seconds to complete a change
<b>TARESET, DEVICE=EXT, RESET</b>	Up to 10 seconds to complete

*Note*

*LabVIEW drivers are available for the molbox2. These drivers allow users of the National Instruments' LabVIEW environment to create systems that include one or more molbox2-S using LabVIEW virtual instruments instead of using the remote commands directly. The molbox2 LabVIEW drivers are an abstraction of the remote commands into a consistent set of common and specific instrument functions. The drivers can be obtained at no charge from the Fluke Calibration web site.*

## RS232 Interface

To establish RS232 communications, a standard pin to pin DB-9F to DB-9M RS232 cable must be used to connect the host COM port to molbox2 COM1. The interface settings of both ports must be the same.

*Note*

*molbox2 supports an independent RS232 self-test to make sure that the molbox2 RS232 ports operate correctly and the interface cable used is valid. Use this self-test to troubleshoot if there is difficulty establishing communications with molbox2 COM1.*

## COM1

The molbox2 COM1 RS232 interface is on the rear panel. The interface is a 9-pin male DB-9F connector configured as a DCE device. Data transmits out of molbox2 on pin 2, and is received on pin 3. This allows a standard pin to pin DB-9M to DB-F RS232 cable to be used to connect to a DTE host. Handshaking is not required or supported.

COM1 RS232 commands must be terminated with at least a single carriage return character, while line feed characters are ignored. All RS232 responses from the molbox2 are terminated with a carriage return character and a line feed character. See [Table 24](#).

**Table 24. COM1 DB-9F Pin Designation**

Pin #	Function	Description
2	TxD	This pin transmits serial data from the molbox2 to the host.
3	RxD	This pin accepts serial data from the host computer.
5	Grn	This pin is the common return for the TxD and RxD signals.

IBM PC/XT DB-9F CONNECTIONS		IBM PC/XT DB-9M TO PPC3 DB9F CONNECTION	
DB-25M	DB-9F	DB-9M	DB-9F
2	3	3	3
3	2	2	2
7	5	5	5

## COM2

The molbox2 COM2 RS232 interface is on the rear panel. The interface is a 9-pin female DB-9M connector configured as a DTE device. Data is transmitted out of the molbox2 on pin 3 and is received on pin 2. This allows a standard pin to pin DB-9F to DB-9M RS232 cable to be used to connect to a DCE secondary unit. Handshaking is not required or supported.

The user can use COM2 to allow the host computer to communicate with another device (for example, another molbox or multimeter) through the molbox2. This allows the user to use one host COM port or IEEE-488 port to communicate with the molbox2 and an additional RS232 device. Refer to the "#" remote command for details (see [molbox2 commands](#), # Command). See [Table 25](#).

**Table 25. COM2 DB-9M Pin Designation**

Pin #	Function	Description
2	RxD	This pin accepts serial data from another molbox2 or another device.
3	TxD	This pin transmits serial data from the molbox2 to another molbox2 or another device.
4	DTR	Data Terminal Ready. Held at +5 V.
5	Grn	This pin is the common return for the TxD and RxD signals.

IBM PC/XT DB-25F to DB-9M Connections		IBM PC/XT DB-9F to molbox2 DB9M Connection	
DB-25F	DB-9M	DB-9F	DB-9M
2	3	3	3
3	2	2	2
7	5	5	5

## IEEE-488 (GPIB)

The molbox2 IEEE-488 interface is on the rear panel. The physical and electrical interface conforms to IEEE Std 488.1-1987 Subset E2 and IEEE Std. 488.2-1992. Do not attempt to communicate with the IEEE-488 interface while using the COM1 interface. The IEEE-488 receive buffer is 250 bytes deep. The molbox2 holds off release of the NRFD handshake line until it can service and empty the receive buffer. This keeps the buffer from overflowing.

Terminate IEEE-488 commands with a single line feed character along with the assertion of the EOI line. All IEEE-488 responses from the molbox2 are terminated with a line feed character along with the assertion of the EOI line. Replies are held in a buffer until the host computer gets them, so it is possible to have old replies in this buffer, while you are expecting new replies from a just issued command.

## Commands

### Command Syntax

All molbox2 commands are ASCII strings. The user must wait for the molbox2 to reply before it can send another command. An exception to this is the use of any of the IEEE STD. 488.2 common commands with the IEEE-488 interface (these common commands are shown first, and always start with an asterisk, (\*). The common commands only generate a reply if the COM1 port is used or the query form of the common command is used (command followed by a ?). See [Table 26](#).

## Command Summary

**Table 26. Command Summary**

Syntax	Purpose
<b>*CLS</b>	Clears the status registers and all queues.
<b>*ESE(?)</b>	Read or set the Event Status Enable register.
<b>*ESR?</b>	Read the Event Status Register.
<b>*IDN?</b>	Identify the Product and software version.
<b>*OPC(?)</b>	Read or set the Operation Complete register (not applicable to the molbox2).
<b>*OPT?</b>	Read the molbox2 options installed.
<b>*RST</b>	Reset user settings to factory defaults.
<b>*SRE(?)</b>	Read or set the Service Request Register.
<b>*STB?</b>	Read the Status Byte.
<b>*TST?</b>	Read the system self-test results.
<b>#</b>	Send a command string out of the molbox2 COM2 port.
<b>AUTOZERO(=)</b>	Read or set the status of the reference pressure transducers (RPTs) <i>AutoZ</i> function.
<b>ABORT</b>	Stop an active averaging, tare, leak check or purge cycle.
<b>AIRW</b>	Read or set the humidity ratio of the gas, AIR.
<b>ALLR</b>	Read the next measurement of molbloc flow, the molbox2 up and downstream RPT pressure values, and molbloc temperature.
<b>BEEPER</b>	To actuate the internal buzzer for half of a second.
<b>BPR(=)</b>	Read or set the back pressure ratio mode when using a sonic nozzle.
<b>CIN</b>	Read the MFC measurement current if in <i>mA</i> mode.
<b>COMn(=)</b>	Read or set the configuration of the COM1 or COM2 port.
<b>COU(=)</b>	Read or set the current for an external MFC if in <i>mA</i> mode.
<b>DATE(=)</b>	Read or set the internal clock date.
<b>DEVICE=</b>	Loads information on molbloc connected to molbox2 into molbox2.
<b>DP</b>	Read the differential pressure value being used to calculate flow.
<b>DRV</b>	Read or set the status of an external solenoid valve.
<b>ERR</b>	Read the last error message.
<b>FA=</b>	Start a single flow averaging cycle.
<b>FCOEF</b>	Read the coefficient to convert kg/s to the current flow units.

**Table 26. Command Summary (cont.)**

<b>Syntax</b>	<b>Purpose</b>
<b>FR</b>	Read the next flow measurement.
<b>FRA</b>	Read the results of a completed flow averaging cycle.
<b>FUNIT(=)</b>	Read or set the flow display unit.
<b>GAS(=)</b>	Read or set the gas type being used.
<b>GASCAL(=)</b>	Read or set the active molbloc calibration to use.
<b>GASCALS</b>	List all calibrations available in the active molbloc.
<b>ID (=)</b>	Read or set the molbox2 ID.
<b>KFACT(=)</b>	Read or set the <i>K</i> factor.
<b>LEAKCK(=)</b>	Start a molbox2 or system leak check cycle or check if a cycle is complete.
<b>LOCAL</b>	Enable the front panel controls if in remote and go to local.
<b>MEM</b>	Read the memory test status.
<b>MFCCH(=)</b>	Read or set the MFC channel and output mode (voltage or current).
<b>MOLBLOC</b>	Read the active molbloc header data. Does not load molbloc information.
<b>OHMS</b>	Read the most recent measurement of the active molbloc's two PRTs.
<b>PCAL</b>	Read or set the user RPT calibrations.
<b>PCALDATE(=)</b>	Read or set the user RPT calibration dates.
<b>PCOEF</b>	Read the coefficient to convert Pascal to the current pressure units.
<b>PR</b>	Read the next molbloc average pressure.
<b>PRHI</b>	Read the last measured upstream pressure (tare corrected).
<b>PRLO</b>	Read the last measured downstream pressure (tare corrected).
<b>PUNIT(=)</b>	Read or set the pressure display unit.
<b>PURGE(=)</b>	Read the progress of or start the purge cycle.
<b>RANGE</b>	Read the range of the active molbloc.
<b>RATE</b>	Read the next available rate of change of flow.
<b>RE</b>	Read the current Reynolds number.
<b>RES(=)</b>	Read or set the local flow display resolution.
<b>READYCK(=)</b>	Read or set a flag that is cleared by a Not Ready condition.
<b>REMOTE</b>	Enable remote local lockout operation.
<b>RESET</b>	Reset the molbox2 settings to the default operating parameters.
<b>SN</b>	Read the serial number of the molbox2.
<b>SR</b>	Read the next available ready status.
<b>SS(=)</b>	Read or set the stability required for a Ready <*> condition.

**Table 26. Command Summary (cont.)**

<b>Syntax</b>	<b>Purpose</b>
<b>STDRES(=)</b>	Read or set the PRT measurement system auto-calibration reference resistor values.
<b>TARE</b>	Read the current tare conditions and the current tare.
<b>TARESETUP(=)</b>	Prepares the unit to tare.
<b>TARESET(=)</b>	Tare the upstream and downstream RPTs or set tare to a given value.
<b>TCAL (=)</b>	Read or set the molbloc temperature calibration (channel dependent).
<b>TEMP</b>	Read the current molbloc temperature in the current units.
<b>TIME(=)</b>	Read or set the internal clock time.
<b>TOTAL(=)</b>	Read the progress of or start a new totalize cycle.
<b>TUNIT(=)</b>	Read or set the molbloc temperature unit.
<b>UDU(=)</b>	Read or set the user definable pressure unit.
<b>UL(=)</b>	Read or set the upper limit for the internal RPTs.
<b>UNCEXP</b>	Read the measurement uncertainty of the current molbloc in the current gas.
<b>USERCAL(=)</b>	Read or set the user flow measurement adjustment.
<b>UTEMP(=)</b>	Read or set the temperature reference used for the user flow units.
<b>VALVE</b>	This command is obsolete and should not be used in new designs.
<b>VER</b>	Read the molbox2 version.
<b>VLM(=)</b>	Read or set the volume units pressure and temperature conditions.
<b>VIN</b>	Read the MFC measurement voltage if in voltage mode.
<b>VOUT(=)</b>	Read or set the voltage sent to an external MFC if in voltage mode.
<b>VSENSE</b>	Read the voltage sensed at the MFC terminal.
<b>VSUPPLY</b>	Read MFC supply voltage.
<b>VVALTEST</b>	Read voltage sensed at MFC valve test terminal.
<b>ZOFFSET:HI</b>	Read or set the AutoZ pressure offset, ( $P_{offset}$ ), for the high RPT.
<b>ZOFFSET:LO</b>	Read or set the AutoZ pressure offset, ( $P_{offset}$ ), for the low RPT.

## Error Messages

molbox2 always replies to a command. If the command is incorrect or contains invalid data, an error number is returned in the form *ERR# n* where *n* is an integer number that represents a specific error. This allows for easy error trapping by the host computer. [Table 27](#) is a list of the possible error numbers and the error description for each.

**Table 27. Error Messages**

<b>Reply</b>	<b>Description</b>
ERROR	The molbox2 is in high security level and cannot accept remote commands
ERR# 0	OK
ERR# 1	molbloc flow is too great
ERR# 2	Text argument is too long
ERR# 3	User defined coefficient cannot be 0
ERR# 4	External device not detected
ERR# 5	External device improperly configured
ERR# 6	Numeric argument missing or out of range
ERR# 7	Missing or improper command argument(s)
ERR# 8	External device timeout error
ERR# 9	Unknown command
ERR# 10	MFC not defined or selected
ERR# 11	Command missing argument
ERR# 12	System overpressured
ERR# 13	Text detected in numeric field
ERR# 14	User unit not defined
ERR# 15	Averaging cycle not started
ERR# 16	MFC Malfunction
ERR# 17	Selected gas not available
ERR# 18	Command not yet available
ERR# 21	User device not defined
ERR# 22	Pressure is not stable
ERR# 23	Option not available or installed
ERR# 24	molbloc not detected
ERR# 25	RPT out of calibration
ERR# 26	COM port failed to initialize
ERR# 27	Internal device #1 timeout error
ERR# 28	Internal device #2 timeout error
ERR# 29	Busy averaging

**Table 27. Error Messages (cont.)**

<b>Reply</b>	<b>Description</b>
ERR# 30	Fatal mass flow calculation error
ERR# 31	molbloc EEPROM is full
ERR# 32	molbloc gas not found
ERR# 34	molbloc is write protected
ERR# 35	molbloc write error
ERR# 36	MFC unit mismatch
ERR# 37	Incompatible device detected
ERR# 38	Selected range not available
ERR# 39	molbloc verify error
ERR# 40	molbloc read error
ERR# 41	molbloc invalid
ERR# 42	PRT measurement error
ERR# 43	Incorrect MFC mode
ERR# 44	Entry already exists
ERR# 45	Argument(s) not allowed
ERR# 46	The leak is too large
ERR# 47	Temperature change was too great
ERR# 48	Offset was excessive. Check tare
ERR# 49	Possible upstream leak
ERR# 50	Possible downstream leak
ERR# 51	Possible bypass leak
ERR# 52	Not available in AB mode
ERR# 53	Suffix not allowed
ERR# 54	Suffix missing or out of range
ERR# 55	Not Ready

### **Command Descriptions**

Each command description gives the full syntax that shows usage. Ranges of parameters or parameter types are indicated. There are 2 types of commands. The common and status commands support IEEE Std. 488.2, while the molbox2 commands access all other functions.

## IEEE Std. 488.2 Common and Status Commands

The molbox2 supports a set of commands that are common to all instruments that conform to IEEE Std. 488.2 protocol. Though defined by the IEEE-488.2 standard, they also apply to molbox2 RS232 (COM1) communications. These commands make it easy to perform basic functions for any device that supports them. These command also cover the status reporting commands. Refer to [Status System](#) details on the status registers mentioned in these commands. Query forms of these commands must be followed by a question mark and IEEE-488.2 Common Commands always start with an asterisk (\*). Unlike the other molbox2 commands, they must have a space instead of an equals sign (=) between the command and any arguments. Also unlike the other molbox2 commands, if you use the IEEE-488 port, the query form (command is immediately followed by a ?) must be used to get a reply. If you use the COM1 port and the command is not a query, *OK* will be replied.

<b>*CLS</b>		
Purpose	Clear all of the status and event structures.	
Syntax	"*CLS"	
Remarks	This program message clears the following evens and status registers: Standard Byte Register (STB) Standard Event Status Register (ESR) Error Queue Pending OPC operations	
Example	Command:	"*CLS"
	Reply:	"OK" (using COM1. No reply if IEEE-488 port)

<b>*ESE(?)</b>	
Purpose	Read or set the Standard Event Status Enable Register.
Syntax	"*ESE <i>n</i> " "*ESE?"
Parameters	<i>n</i> : '0 to 255'. This is the decimal representation of the bit(s) to enable. To enable the PON and QYE bits, the argument would be 128 + 4 = 132.
Query Reply	<i>n</i> (0 to 255)
Remarks	The Standard Event Status Enable register determines which bits in the standard Event Status Register are enabled and included in the Status Byte Register (ESB bit), and can assert the SRQ line. The reply is in decimal numeric form.
Example	Command:    "*ESE 132" Reply:        "OK" (using COM1. No reply if IEEE-488 port) Command:    "*ESE?" Reply:        "132"

<b>*ESR?</b>	
Purpose	Read the Standard Event Register.
Syntax	"*ESR?"
Query Reply	<i>n</i> (0 to 255)
Remark	The Standard Event Register contents are cleared after reading. The reply is in decimal numeric form.
Example	Command:    "*ESR?" Reply:        "4"

<b>*IDN?</b>	
Purpose	Identify the molbox2 version, range, and serial number.
Syntax	"*IDN?"
Remarks	The identification reply is made up of the manufacturer, the model, the serial number, the internal RPT serial numbers and the software version. Each is separated by a comma.
Query Reply	The version string.
Example	Command:    "*IDN?" Reply:        "FLUKE, molbox2, 620-84836-85056, Ver6.00-ngmg1"

<b>*OPC(?)</b>		
Purpose	Sets the operation complete bit when all operations have completed.	
Syntax	"*OPC"	
	"*OPC?"	
Remarks	<p>This command enables the molbox2 to set the OPC bit in the Standard Event Status Register when it has completed all pending functions. The Query replies with a "1" when all functions are complete.</p> <p>Since the molbox2 does not support overlapping commands, this command has no practical use.</p>	
Query Reply	"0" or "1"	
Example	Command:	"*OPC"
	Reply:	"OK" (using COM1. No reply if IEEE-488 port)
	Command:	"*OPC?"
	Reply:	"1"

<b>*OPT?</b>		
Purpose	Reads the list of installed molblox1 options.	
Syntax	"*OPT?"	
Remarks	This Query returns any registered option(s) installed in the molbox2. Each option is separated by a comma.	
Query Reply	A comma delimited text field of the installed options.	
Example	Command:	"*OPT?"
	Reply:	"NONE" (no options installed)

<b>*RST</b>		
Purpose	Resets the molbox2 settings to factory settings.	
Syntax	"*RST"	
Remarks	<p>This command sets the molbox2 settings to factory settings which is equivalent to pushing  <b>&lt;5Reset&gt;, 1sets</b>. This does not affect the communications settings.</p>	
Example	Command:	"*RST"
	Reply:	"OK" (using COM1. No reply if IEEE-488 port)

<b>*SRE(?)</b>		
Purpose	Read or set the Service Request Enable Register.	
Syntax	"*SRE <i>n</i> "	
	"*SRE?"	
Parameters	<i>n</i> :	'0 to 255'. This is the decimal representation of the bit(s) to enable. To allow the MAV and ESB bits to assert the SRQ line, the argument would be 32 + 16 = 48. Bit 6 (64) is reserved and cannot be set.
Remarks	The Service Request Enable Register determines which bits of the Status Byte can set the MSS bit of the Status Byte and request service by asserting the SRQ line of the IEEE-488 interface.	
Query Reply	<i>n</i> (0 to 255)	
Example	Command:	"*SRE 48"
	Reply:	"OK" using COM1. No reply if IEEE-488 port)
	Command:	"*SRE?"
	Reply:	"48"

<b>*STB?</b>		
Purpose	Read the Status Byte Register.	
Syntax	"*STB?"	
Remarks	The Status Byte Register reflects the general status of the molbox2. The 'MSS' bit state is represented by bit 6.	
Query Reply	<i>n</i> (0 to 255)	
Example	Command:	"*STB?"
	Reply:	"4"

<b>*TST?</b>		
Purpose	Read the power on self test status.	
Syntax	"*TST?"	
Remarks	The molbox2 system memory stores the user settings (units, mode, resolution) and retains them when the unit is shutoff. On power up, this memory is checked. If this memory is corrupted, all user settings are reset to default (as if the "*RST" program message was executed), and the *TST query returns a '1'. If the molbox2 passed the test on power up OR if the *TST query was used at least once since the unit was powered up the reply is '0'.	
Query Reply	"0" or "1"	
Example	Command:	"*TST?"
	Reply:	"1"

molbox2 commands

<b>#</b>		
Purpose	To allow the Host computer to communicate with a device connected to the molbox2 COM2 port.	
Syntax	"#XX"	
Arguments	xx:	The string to send out of the COM2 port. It must be less than 40 characters long.
Remarks	<p>The molbox2 COM2 port can be used to communicate to another RS232 device (e.g., another molbox2 or a multimeter). This allows the user to use one COM port or IEEE-488 port on the host computer to communicate with the molbox2 and another device. A carriage return and a line feed (&lt;CR&gt;&lt;LF&gt;) are added to the string.</p> <p>After this command is issued, the molbox2 will reply back the first string received by the molbox2 COM2 port that is terminated with a carriage return. Line feeds are discarded. This will discontinue when the next command is sent to the molbox2.</p> <p>There is no other reply from this command. Prior to using this command, you must ensure that the molbox2 COM2 port is correctly set up to communicate with the device. Refer to the "COM2=" command.</p>	
Example	Command:	"#VER"
	Reply:	"FLUKE, molbox RFM Ver1.20"

<b>ABORT</b>		
Purpose	To stop an active averaging, <i>tare</i> , purge, leak check cycle, or reset the list of gas calibrations on a molbloc.	
Syntax	"ABORT"	
Remarks	<p>Confirms that molbox2 is in a known state. The <i>tare</i>, purge, and leak check cycles put the molbox2 into a condition where it is not usable for normal flow measurement, so enter the "ABORT" command before general operation of the unit begins if the previous state of the unit is not known. The "ABORT" command also clears out any previous leak or <i>tare</i> cycle errors. If the "GASCALS" command is used to list the calibrated gases on a molbloc, the "ABORT" command resets the list back to the beginning.</p>	
Example	Command:	"ABORT"
	Reply:	"ABORT"
See Also	"FA", "TARESETUP", "LEAKCK", "PURGE", "GASCALS"	

<b>AIRW(=)</b>		
Purpose	Read or set the humidity ratio for the gas, AIR.	
Syntax	"AIRW= <i>HumidityRatio</i> " "AIRW"	
Default	"AIRW=0.0000" "	
Arguments	HumidityRatio:	The humidity ratio (0-0.1)
Remarks	The humidity ratio is only used if the gas is set to specify AIR. For all other gas types, the ratio is ignored.	
Example	Command: Reply:	"AIRW=.01" "0.0100"
Errors	ERR# 6:	The humidity ratio is invalid.
See Also	<a href="#">molbloc-S Operation</a> , <a href="#">molbloc-S Operation</a> "GAS"	

<b>ALLR</b>		
Purpose	Read the next ready/not ready indication, measurement of molbloc flow, the molbox2 upstream and downstream RPT pressure values and the molbloc temperature.	
Syntax	"ALLR"	
Remarks	<p>The next available measurements are replied. This can take up to 1 second, since the molbox2 waits for the next flow measurement before replying. The reply starts with the flow ready information. Then the flow value is given in the current flow units. Commas are then used to separate the other measurements in this order:</p> <p>"RDY flow, avgpres, uppres, dnpres, temp".</p> <p>"RDY" is the flow ready field. The ready status is covered in the "SR" command.</p> <p>"flow" is the current measured flow and flow units. "-999999" in this field when using a molbloc-S indicates that the BPR is too low for a correct flow measurement.</p> <p>"avgpres" is the average of the upstream and downstream RPTs and units.</p> <p>"uppres" is the upstream RPT pressure measurement and units.</p> <p>"dnpres" is the downstream RPT pressure measurement and units.</p> <p>"temp" is the molbloc temperature and units.</p>	
Example	Command: Reply:  Reply:	<p>"ALLR"</p> <p>"R 0.00075 slm,97.3844 kPa,97.3945 kPa,97.3743 kPa, 17.97C"</p> <p>"NRP -999999 slm,97.3844 kPa,97.3945 kPa,97.3743 kPa, 17.97C" (BPR too low)</p>
Errors	ERR# 27 or 28:	One of the RPTs (pressure transducers) is not functioning.
See Also	"SR", "READYCK", "DP", "PRHI", "PRLO", "FR", "TEMP"	

<b>AUTOZERO(=)</b>		
Purpose	Read or set the status of the reference pressure transducer (RPT) AutoZ function.	
Command	"AUTOZERO= <i>n</i> "	
Query	"AUTOZERO"	
Default	"AUTOZERO=1"	
Arguments	<i>n</i> :	'0' Autozero OFF '1' Autozero ON
Remarks	The molbox2 "AutoZ" function can be turned ON and OFF. This command sets the AutoZ status for both of the internal RPTs.	
Example	Sent:	"AUTOZERO=1"
	Query reply:	"AUTOZERO=1"
Errors	ERR# 6:	The argument was other than a '0' or a '1'.
See Also	<a href="#">&lt;4AutoZ&gt;</a> , "ZOFFSET:XX"	

<b>BEEPER(=)</b>		
Purpose	To actuate the internal buzzer for half of a second.	
Syntax	"BEEPER" "BEEPER=freq"	
Arguments	freq:	This variable has no purpose, but is included for compatibility with the RFM product.
Remarks	The internal buzzer tone is fixed, so the argument serves no purpose.	
Example	Command:	"BEEPER=1000"
	Reply:	"1000"

<b>CIN</b>		
Purpose	Read the MFC measurement current if in 'mA' mode.	
Syntax	"CIN"	
Remarks	The optional MFC interface can measure current output of an MFC. The molbox2 must be in 'mA' mode before this can be done (see the "MFCCH" command). The returned data is always in "mA".	
Example	Command:	"CIN"
	Reply:	"5.34 mA"

<b>COMn(=)</b>		
Purpose	To set or read the configuration of the COM1 or COM2 ports.	
Syntax	"COMn=baud,parity,data,stop" "COMn"	
Arguments	n:	The COM port: '1' or '2'.
	Baud:	The baud rate. This may be '300', '600', '1200', '2400', '4800', '9600' or '19200'.
	parity:	The data parity. This may be 'O' for odd, 'E' for even or 'N' for none.
	data:	The data word length. This may be '7' or '8'.
	stop:	The number of stop bits. This may be '1' or '2'.
Defaults	"COM1=2400,E,7,1" "COM2=2400,E,7,1"	
Remarks	<p>The COM1 port is used to communicate to the molbox2. When the COM1 port configuration of the molbox2 is changed, the command reply will be sent at the old COM1 settings, but all subsequent communications will be accomplished at the new COM1 settings.</p> <p>The COM2 port is used to allow commands to be passed through the molbox2 to a device connected to the COM2 port (refer to the '#' command).</p>	
Example	Command:	"COM1=9600,N,8,1"
	Reply:	"9600,N,8,1"
Error	ERR# 7:	Missing or improper command argument(s).
See Also	<a href="#">COM1 and COM2</a>	

<b>DATE(=)</b>		
Purpose	Read or set the internal clock date.	
Syntax	"DATE" "DATE=yyyymmdd"	
Arguments	yyyy:	The year from 1980 to 2079.
	mm:	The month from 1 to 12.
	dd:	The day from 1 to the last valid day of the given month.
Example	Command:	"DATE=19981005"
	Reply:	"19981005"
Errors	ERR# 6:	The time date is invalid.
See Also	<a href="#">&lt;3Time&gt;</a>	

<b>COUT(=)</b>		
Purpose	Set a current to the MFC if in current mode.	
Syntax	"COUT=current"	
Arguments	Current:	The current to be sent to the MFC (4 to 20 mA).
Defaults	"COUT=4"	
Remarks	The optional MFC interface can set a current for an MFC. The molbox2 must be in current mode before this can be done (see the "MFCCH" command). The data is always in "mA". This command does not change the regulation mode target for the MFC.	
Example	Command:	"COUT=12"
	Reply:	"12.00 mA"
See Also	<a href="#">[MFC] (Optional)</a>	

<b>DP</b>	
Purpose	Read the differential pressure value used by molbox2 to calculate flow.
Syntax	"DP"
Remarks	The molbox2 has upstream and downstream absolute RPTs. The pressure returned by this command is the differential pressure value that is being used by molbox2 to calculate flow. This is the <i>tare</i> adjusted difference between the 2 absolute RPTs. The first 3 characters of the reply from molbox2 make up the <i>Ready/Not Ready</i> condition (see the "SR" command). The differential pressure string follows it.
Example	Command: "DP" Reply: "R 0.0227 kPa"
See Also	"SR"

<b>DRVn(=)</b>		
Purpose	Read or set the status of an external solenoid valve.	
Syntax	"DRVn=x" "DRVn"	
Arguments	N X	The valve to operate on. This can be from 1 to 8. The state to change the valve to. '0' to de-activate it. '1' to activate it.
Defaults	"DRVn=0"	
Remarks	The molbox2 has the option of controlling up to eight external valves.	
Example	Command: Reply:	"DRV3" "DRV3=1"
Errors	ERR# 6:	The n or x arguments are not within given limits.
See Also	<a href="#">&lt;7Drivers&gt;</a> , <a href="#">Valve Drivers</a>	

<b>ERR</b>					
Purpose	Read the last error message.				
Syntax	"ERR"				
Remarks	The "ERR" command provides more details about an error that has occurred. If the user receives an "ERR# nn" reply, the "ERR" command returns a brief description about the last error number that was replied.				
Example	<table border="1" style="width: 100%;"> <tr> <td style="width: 20%;">Command:</td> <td>"ERR"</td> </tr> <tr> <td>Reply:</td> <td>"Missing or improper command argument(s)"</td> </tr> </table>	Command:	"ERR"	Reply:	"Missing or improper command argument(s)"
Command:	"ERR"				
Reply:	"Missing or improper command argument(s)"				
See Also	<a href="#">Error Messages</a> , "*CLS"				

<b>FA=</b>					
Purpose	Start a single flow averaging cycle.				
Syntax	"FA=period"				
Arguments	<table border="1" style="width: 100%;"> <tr> <td style="width: 20%;">period:</td> <td>The averaging period in seconds (from 20 to 999 seconds if A+B mode, otherwise 4-999 seconds).</td> </tr> </table>	period:	The averaging period in seconds (from 20 to 999 seconds if A+B mode, otherwise 4-999 seconds).		
period:	The averaging period in seconds (from 20 to 999 seconds if A+B mode, otherwise 4-999 seconds).				
Remarks	Starts an averaging period that results in the average molbloc flow, MFC measurement, and standard deviation of the molbloc flow over this period. After sending this command you can monitor the averaging cycle by using the "FR" or "SR" command to determine when the averaging cycle is complete. Once the cycle is done, you must use the "FRA" command to collect the results.				
Example	<table border="1" style="width: 100%;"> <tr> <td style="width: 20%;">Command:</td> <td>"FA=20"</td> </tr> <tr> <td>Reply:</td> <td>"20 s"</td> </tr> </table>	Command:	"FA=20"	Reply:	"20 s"
Command:	"FA=20"				
Reply:	"20 s"				
Errors	ERR# 6: The period argument is not within the specified limits.				
See Also	<a href="#">&lt;2Avg&gt; (Average)</a> , "FR", "SR", "FRA", "ABORT"				

<b>FCOEF</b>					
Purpose	Read the coefficient that converts kg/s to the current flow units.				
Syntax	"FCOEF"				
Remarks	The flow coefficient is a value that is used to convert kg/s to the current flow units. It is dependent on the current flow unit and the gas selected. To use this coefficient, multiply it by kg/s to get flow in the current flow units.				
Example	<table border="1" style="width: 100%;"> <tr> <td style="width: 20%;">Command:</td> <td>"FCOEF"</td> </tr> <tr> <td>Reply:</td> <td>"4.798073e+004"</td> </tr> </table>	Command:	"FCOEF"	Reply:	"4.798073e+004"
Command:	"FCOEF"				
Reply:	"4.798073e+004"				
See Also	<a href="#">[UNIT]</a> , <a href="#">Flow</a>				

<b>FR</b>		
Purpose	Read the next measurement of flow through the molbloc as calculated by the molbox2.	
Syntax	"FR"	
Remarks	<p>The next available flow value is read in the current flow units. This can take up to 1 second, since the molbox2 waits for the next flow measurement before replying. The reply also contains ready information.</p> <p>The first 3 characters are reserved for the <i>Ready/Not Ready</i> status. The <i>Ready/Not Ready</i> status is covered in the "SR" command. The flow measurement number starts at the fifth character, and is followed by the flow units.</p>	
Example	Command:	"FR"
	Reply:	"R 0.00001 sccm"
Errors	ERR# 27:	One of the RPTs (transducer) is not functioning.
	"BUSY"	The molbox2 is busy calculating an A+B flow value.
See Also	<a href="#">Flow Ready/Not Ready Indication</a> , "SR", "READYCK", "ALLR"	

<b>FRA</b>		
Purpose	Read the results of a completed flow averaging cycle.	
Syntax	"FRA"	
Remarks	<p>This command is used to check on the status of or collect the results of an averaging cycle that was started earlier using the "FA=" command. During the averaging cycle, this command will reply "BUSY" until the averaging cycle is complete. Then the reply will be the results of the averaging cycle. If the cycle is aborted before it is complete (see "FA="), then the data will be lost.</p> <p>The data that is returned from the command consists of multiple numeric fields delimited by commas. The flow numbers are in the current flow unit of measure. The actual data fields returned are as follows:</p> <p>An "H" will appear as the first character of the reply string. An "S" will appear as the second character of the string if the flow stability stayed within the stability setting during the sequence. From the fourth position on the numeric data fields are:</p> <p>Average flow over the averaging period.</p> <p>Standard deviation of flow over the averaging period.</p> <p>The minimum flow reached during the period.</p> <p>The maximum flow reached during the period.</p> <p>The MFC voltage or current target or "NA" if MFC option not enabled.</p> <p>The MFC voltage or current average measurement or "NA" if MFC option not enabled.</p>	
Example	Command:	"FRA"
	Reply:	"HS 0.00002 sccm,0.00000,0.00002,0.00002,0.5000 V,0.1203 V"
	Reply:	"HS 0.00002 sccm,0.00000,0.00002,0.00002,NA, NA" (MFC disabled)
		"BUSY" if still averaging
Errors	ERR# 15:	The "F=" command was not sent previous to this command.
See Also	"FR", "SR", "FA"	

<b>FUNIT(=)</b>		
Purpose	Read or set the unit of measurement for the flow through the molbloc as calculated by the molbox2.	
Syntax	"FUNIT= <i>unit</i> " "FUNIT"	
Defaults	"FUNIT=sccm"	
Arguments	unit:	The flow unit used to display the measured flow.
Remarks	The flow unit displayed can be changed using this command. The flow unit must be supported by the molbox2. The flow unit protocol is the same as the front panel flow unit definitions.	
Example	Command: Reply:	"FUNIT=SLM" "SLM"
Errors	ERR# 7:	The flow unit is invalid or not supported by the molbox2.
See Also	<a href="#">[UNIT]</a> , "UTEMP", "VLM"	

<b>GAS(=)</b>		
Purpose	Read or set the gas type being flowed through the molbloc.	
Syntax	"GAS= <i>gas</i> " "GAS"	
Arguments	gas:	Specify the gas to use.
Remarks	The calibration for the gas type being flowed through the molbloc is specified using this command. The gas must be supported by the molbox. The gas type protocol is the same as the front panel gas definitions. A valid molbloc must be connected to the molbox2 before changing the gas type. If several calibrations exist for the given gas, then the "default" calibration for the gas specified will be used. If a calibration for the specified gas does not exist, then the molbloc's default calibration will be used. The "GASCAL" command can be used to query what calibration is being used. The "GASCAL" command can also be used to specify the exact calibration to use if multiple calibration exist for a specific gas..	
Example	Command: Reply:	"GAS=N2" "N2"
Errors	ERR# 7: ERR# 24: ERR# 32: ERR# 35: ERR# 39: ERR# 40: ERR# 41:	The gas is invalid for the molbox2. A molbloc is not connected to the molbox2. This gas is not supported by the molbox2. The molbloc experienced a communications time out. The molbloc experienced a data verification failure. The molbloc experienced a read checksum failure. The molbloc data header is corrupted.
See Also	"AIRW"	

<b>GASCAL(=)</b>	
Purpose	Read or set the active molbloc calibration to use.
Command	"GASCAL= <i>gas</i> ( <i>, calname</i> )"
Query	"GASCAL"
Default	"GASCAL=N2"
Arguments	<p><i>gas</i>: Calibration gas.</p> <p><i>calname</i>: Calibration name (optional. Same as <i>gas</i> assumed if blank or ignored if molbloc does not have named calibrations)</p>
Remarks	A molbloc can contain multiple calibrations, possibly for each gas. The calibration should be selected before use. This command selects the desired calibration by referring to the calibration gas, and optionally by the unique name given to the calibration for that gas if the molbloc supports multiple calibrations. The "GASCALS" command should be used prior to the "GASCAL" command to determine what calibrations are available in the molbloc.
Example	<p>Sent: "GASCAL=HE, LOP"</p> <p>Query reply: "HE, LOP"</p> <p>Sent: "GASCAL=HE" (<i>calname</i> not given so "HE" is assumed)</p> <p>Query reply: "HE, HE"</p>
Errors	<p>ERR# 2: The gas or calibration name given is too long.</p> <p>ERR# 24: A molbloc is not connected to the molbox.</p> <p>ERR# 32: The calibration was not found.</p> <p>ERR# 35: The molbloc experienced a communications time out.</p> <p>ERR# 40: The molbloc experienced a read checksum failure.</p>
See Also	<p>"GASCALS" command</p> <p>"GAS" command</p>

<b>GASCALS</b>					
Purpose	List out the calibrations in an active molbloc.				
Query:	"GASCALS"				
Remarks	<p>All of the calibrations in an active molbloc created with molbox version 6.00 or greater can be listed one at a time using the GASCALS command. You MUST first send the ABORT command to "reset" the listing of the calibrations, then send the "GASCALS" command to get each calibration until there are no more calibrations. Here are the 4 fields that are returned for each calibration found:</p> <p>Calibration gas: The name of the gas for this calibration. This is one of the know gas types supported by the molbox</p> <p>Calibration name: The unique name for this calibration. (Only present on molblobs with named calibrations)</p> <p>Calibration range: The range and range unit for this calibration. (Only present on molblobs with named calibrations)</p> <p>Attributes: Each calibration has several attributes. These attributes are reported as a sum of the possible attribute values (Only present on molblobs with named calibrations):</p> <p>'1' NOT a default calibration. Default calibrations are used when the "GAS=" command is used to specify which calibration to use using just the gas name. This attribute when set indicates that this is NOT a default calibration</p> <p>'4' Calibration is a "premium" calibration.</p> <p>'8' Calibration is a "downstream" calibration.</p>				
Example	<table border="0"> <tr> <td style="vertical-align: top;">Sent:</td> <td>"GASCALS"</td> </tr> <tr> <td style="vertical-align: top;">Reply:</td> <td>           "He, LOP ,1 slm, 0" Named default calibration            "He, LOP ,1 slm, 4" Default premium calibration            "He, LOP ,1 slm, 6" Default premium calibration. Other He calibration exist on this molbloc            "He" molbloc does not supports named calibrations         </td> </tr> </table>	Sent:	"GASCALS"	Reply:	"He, LOP ,1 slm, 0" Named default calibration "He, LOP ,1 slm, 4" Default premium calibration "He, LOP ,1 slm, 6" Default premium calibration. Other He calibration exist on this molbloc "He" molbloc does not supports named calibrations
Sent:	"GASCALS"				
Reply:	"He, LOP ,1 slm, 0" Named default calibration "He, LOP ,1 slm, 4" Default premium calibration "He, LOP ,1 slm, 6" Default premium calibration. Other He calibration exist on this molbloc "He" molbloc does not supports named calibrations				
Errors	ERR# 32: No more calibrations exist in the molbloc.				
See Also	"ABORT" command "GAS" command "GASCAL" command				

<b>ID(=)</b>	
Purpose	Read or set the user defined identification label.
Syntax	"ID=string" "ID"
Default	"ID=NONE"
Arguments	String:            An alphanumeric string up to 12 characters wide.
Remarks	The user defined ID label can be used to allow the user to "tag" the molbox2 with a unique identifier. This ID is stored in non-volatile memory and cannot be erased by a power failure, system fault or reset.
Example	Command:            "ID=molbox-001" Reply:                "molbox-001  "
See Also	<a href="#">&lt;3ID&gt;</a>

<b>KFACT(=)</b>	
Purpose	Read or set the molbox2 K factor.
Syntax	"KFACT= <i>kfactor</i> " "KFACT"
Arguments	Kfactor:            The new "K" factor.
Defaults	"FACT=1.0" (Disabled)
Remarks	The "K" factor is set to 1 for normal operation.
Example	Command:            "KFACT" Reply:                "1.000000"
See Also	<a href="#">[K]</a>

<b>LEAKCK(=)</b>																	
Purpose	Starts a molbox2 or system leak check cycle or checks if a cycle is complete.																
Syntax	"LEAKCK=type" "LEAKCK"																
Arguments	<p>type: "BOX". Starts a leak check cycle on the molbox2 internal circuit. The molbox must be prepared for the leak check by setting pressures and venting ports before the leak check is executed.</p> <p>"SYS". Starts a leak check cycle on the system connected to the molbox2. The system must be prepared for the leak check by setting pressures and operating valves before the leak check is executed.</p>																
Remarks	<p>This command is used to start and monitor the progress of the leak check. Both "BOX" and the "SYS" leak checks take 60 seconds to complete. At the end of the leak check, the molbox2 is returned to its normal operating state.</p> <p>The "ABORT" command can be used to stop a leak check cycle, clear out any previous error messages, and return the molbox2 to its normal operating state. While the leak check cycle is executing, a 'b' ("busy") will appear in the 3rd character position of the "FR" and the "SR" command replies.</p> <p>If the leak check failed, an error will be replied to the "LEAKCK" query until the "ABORT" command is used to abort the leak check. When the leak check has completed without an error, the "LEAKCK" query will reply "OK".</p> <p>If a molbloc-S is active and a "SYS" type leak check was run, the reply is the actual average leak rate (in the current pressure units) during the leak check.</p> <p>The "LEAKCK" command must be completed or aborted using the "ABORT" command before performing other operations.</p>																
Example	<table border="0"> <tr> <td>Command:</td> <td>"LEAKCK=BOX,1"</td> </tr> <tr> <td>Reply:</td> <td>"BOX" (starting new molbox2 leak check cycle including the microrange RPT)</td> </tr> <tr> <td>Command:</td> <td>"LEAKCK=SYS"</td> </tr> <tr> <td>Reply:</td> <td>"SYS" (starting new system leak check cycle)</td> </tr> <tr> <td>Command:</td> <td>"LEAKCK"</td> </tr> <tr> <td>Reply:</td> <td>"23 sec" A leak check cycle is currently running. This is the number of seconds remaining in the test.</td> </tr> <tr> <td>Reply:</td> <td>"OK" (The leak check cycle has completed)</td> </tr> <tr> <td>Reply:</td> <td>"0.3412 kPa/s" if a molbloc-S is active and the "SYS" type leak check has been completed.</td> </tr> </table>	Command:	"LEAKCK=BOX,1"	Reply:	"BOX" (starting new molbox2 leak check cycle including the microrange RPT)	Command:	"LEAKCK=SYS"	Reply:	"SYS" (starting new system leak check cycle)	Command:	"LEAKCK"	Reply:	"23 sec" A leak check cycle is currently running. This is the number of seconds remaining in the test.	Reply:	"OK" (The leak check cycle has completed)	Reply:	"0.3412 kPa/s" if a molbloc-S is active and the "SYS" type leak check has been completed.
Command:	"LEAKCK=BOX,1"																
Reply:	"BOX" (starting new molbox2 leak check cycle including the microrange RPT)																
Command:	"LEAKCK=SYS"																
Reply:	"SYS" (starting new system leak check cycle)																
Command:	"LEAKCK"																
Reply:	"23 sec" A leak check cycle is currently running. This is the number of seconds remaining in the test.																
Reply:	"OK" (The leak check cycle has completed)																
Reply:	"0.3412 kPa/s" if a molbloc-S is active and the "SYS" type leak check has been completed.																

Errors	ERR# 6:	One of the arguments is not invalid.
	ERR# 15:	A leak check cycle has not been started.
	ERR# 46:	A large leak exists.
	ERR# 47:	The temperature changed too much to test for a leak.
	ERR# 48:	The absolute RPT disagreement too great to test for a leak.
	ERR# 49:	Possible upstream leak.
	ERR# 50:	Possible downstream leak.
	ERR# 51:	Possible bypass leak.
See Also	<3Leak Check>, "ABORT"	

<b>LOCAL</b>		
Purpose	Enable the front panel controls if in remote and go to local mode.	
Syntax	"LOCAL"	
Remarks	In LOCAL mode, all front panel operations are available. The LOCAL command deactivates REMOTE mode.	
Example	Command:	"LOCAL"
	Reply:	"LOCAL"
See Also	"REMOTE"	

<b>MEM</b>		
Purpose	Read the memory test status.	
Syntax	"MEM"	
Remarks	On power up a memory test is run to check the integrity of the internal data NVRAM. If the memory has been corrupted, "FATAL MEMORY FAULT" will be displayed on power up to alert the user, and the memory test status command will return a '0'. The command will return a '1' if the memory is OK.	
Example	Command:	"MEM"
	Reply:	"0"

<b>MFCCH</b>			
Purpose	Read or set the MFC channel and output mode (voltage or current).		
Syntax	"MFCCH=channel,mode" "MFCCH"		
Defaults	"MFCCH=1,v"		
Arguments	channel:	The optional MFC switchbox channel.	
		0 1 1 to 5	disables the MFC interface. enables the optional MFC interface. selects the MFC channel to use for optional MFC switchbox
	mode:	The MFC interface mode	
		'v' 'mA' , ,	Voltage control and measure mode. The selected channel will be used for voltage setting and measuring. Current loop control and measure mode. The selected channel will be used for current loop setting and measuring. If the argument is not given, the molbox will use the selected channel to measure the voltage, and will always use channel 1 to set the voltage. This is used to measure voltage MFM's that are connected to channel 2 through 5 with an MFC controlling on channel 1.
Remarks	The optional MFC interface can support voltage or current controlled MFC's. There is also an available MFC switchbox, which is controlled by the molbox2.		
Example	Command:	"MFCCH=1,mA" "1,mA"	Enables MFC for current
	Reply:		
	Command:	"MFCCH=3,V" "3,V"	Enables MFC on switchbox channel 3 for volts
	Reply:		
Example	Command:	"MFCCH=0" "0,V"	Disables MFC interface
	Reply:		
	Command:	"MFCCH=1,V" "1,V"	Enables MFC control on channel 1
	Reply: Command: Reply:	"MFCCH=4" "4,V"	Enables MFM input on channel 4
Errors	ERR# 6: ERR# 23: ERR# 23:	Channel or mode arguments are invalid The MFC option is not installed Channel greater than 1 and MFC switchbox option is not installed	
See Also	<a href="#">[MFC] (Optional)</a> , <a href="#">MFC Control Function-MFC Connector</a>		

<b>MOLBLOC</b>	
Purpose	Read the active molbloc header data. This command does NOT load molbloc information into the molbox2, it only accesses previously loaded information.
Syntax	"MOLBLOC"
Remarks	<p>The external molbloc header data includes the serial number, range, calibration date, and PRT calibration data. This data is stored in the molbloc, and is downloaded to the molbox2 on power up. The data for the active molbloc is returned in a single, comma delimited string in the following order:</p> <p>Serial Number Range Designator Range Flow Units Gas Calibration Date (yyyymmdd) Total PRT Resistance (upstream + downstream) at 0 °C [<math>\Omega</math>] PRT Slope [dimensionless] Upstream PRT Resistance at 0 °C [<math>\Omega</math>] Downstream PRT Resistance at 0 °C [<math>\Omega</math>]</p> <p>molbloc-S nozzle Serial Number if the molbloc is a "-S" or same as the molbloc serial number if a the molbloc is a "-L" molbloc.</p> <p>"S", "L", or "L7" depending on whether the molbloc is a "-S" or "-L". The "L7" designation indicates the molbloc is using NIST based gas property data.</p>
Example	<p>Command: "MOLBLOC"</p> <p>Reply: "100, 1.00, sccm, N2, 19980426, 200.0050, 0.7792, 100.0010, 100.0040, 100, L" (molbloc-L with original gas property data)</p> <p>Reply: "100, 1.00, sccm, N2, 19980426, 200.0050, 0.7792, 100.0010, 100.0040, 100, L7" (molbloc-L with NIST based gas properties)</p> <p>Reply: 100, 1.00, sccm, N2, 19980426, 200.0050, 0.7792, 100.0010, 100.0040, 120, S" (molbloc-S)</p>
Errors	<p>ERR# 7: The gas is invalid with the molbox2.</p> <p>ERR# 24: A molbloc is not connected to the molbox2.</p> <p>ERR# 35: The molbloc experienced a communications timeout.</p> <p>ERR# 40: The molbloc experienced a read checksum failure.</p> <p>ERR# 41: The molbloc data header is corrupted.</p>
See Also	< <a href="#">1molbloc</a> >, "DEVICE"

<b>OHMS</b>		
Purpose	Read the most recent measurement of the active molbloc's two PRTs.	
Syntax	"OHMS"	
Remarks	?????	
Example	Sent:	"OHMS"
	Reply:	"109.031 Ohms, 109.037 Ohms"
See Also	<a href="#">OHMIC Measurement [Temperature] System Verification, [P&amp;T] (Pressure and Temperature)</a> , "TEMP"	

<b>PCAL(=)</b>		
Purpose	Read or set the user RPT calibration adjustments ( <i>PA</i> , <i>PM</i> ).	
Syntax	"PCAL=upadder, upmult, dnadder, dnmult" "PCAL"	
Defaults	"PCAL=0, 1.00000, 0, 1.00000"	
Arguments	Upadder:	The upstream RPT calibration <i>adder</i> ( <i>PA</i> ) from -10,000 to 10,000 Pa.
	Upmult:	The upstream RPT calibration <i>multiplier</i> ( <i>PM</i> ) from 0.9 to 1.1.
	Dnadder:	The downstream RPT calibration <i>adder</i> from -10,000 to 10,000 Pa.
	Dnmult:	The downstream RPT calibration <i>multiplier</i> from 0.9 to 1.1.
	Mradder:	The optional microrange RPT calibration <i>adder</i> from -10,000 to 10,000 Pa.
Remarks	The user defined pressure calibration for the upstream and downstream RPTs can be access with this single command. The <i>adder</i> is always in Pascal.	
Example	Command:	"PCAL=38, 1.0021, 14, .9942"
	Reply:	" 38.00 Paa, 1.002100, 14.00 Paa, 0.994200"
Errors	ERR# 6:	Invalid argument.
See Also	<a href="#">Calibration Of Reference Pressure Transducers (RPTS)</a>	

<b>PCALDATE(=)</b>		
Purpose	Read or set the user RPT calibration dates.	
Syntax	"PCALDATE=yyyymmdd, yyyymmdd" "PCALDATE"	
Defaults	"PCALDATE=19980101,19980101"	
Arguments	yyyy:	The year from 1980 to 2079.
	mm:	The month from 1 to 12.
	dd:	The day from 1 to the last valid day of the given month.
Remarks	The user defined pressure calibration dates for the upstream and downstream RPTs can be access with this single command in this order.	
Example	Command:	"PCALDATE=19981005, 19981005"
	Reply:	"19981005, 19981005"
Errors	ERR# 7:	One or more of the date(s) are invalid.
See Also	<a href="#">Calibration Of Reference Pressure Transducers (RPTS)</a> , "PCAL(=)"	

<b>PCOEF</b>		
Purpose	Read the coefficient to convert Pascal [Pa] to the current pressure units.	
Syntax	"PR"	
Remarks	The pressure coefficient (PCOEF) is a value that is used to convert Pascal units to the current pressure units. To use this coefficient, multiply it by pressure in Pascal to get pressure in the current units.	
Example	Command:	"PCOEF"
	Reply:	"1.000000e-003"
See Also	<a href="#">&lt;8PRESU&gt;</a> , <a href="#">Pressure</a> , "PUNIT"	

<b>PR</b>					
Purpose	Read the next molbloc average pressure.				
Syntax	"PR"				
Remarks	<p>The next available average <math>\left(\frac{upstream - downstream}{2}\right)</math> pressure value is read in the current pressure units. It is the average of the <i>tare</i> corrected upstream and the downstream transducers. The data string also contains flow ready information, and the pressure units.</p> <p>The first 3 characters of the reply are reserved for the flow <i>Ready/Not Ready</i> status. The <i>Ready/Not Ready</i> status is covered in the "SR" command. The pressure measurement number starts at the fifth character, and is followed by the pressure unit of measure.</p>				
Example	<table border="0"> <tr> <td>Command:</td> <td>"PR"</td> </tr> <tr> <td>Reply:</td> <td>"R 247.5982 kPa a"</td> </tr> </table>	Command:	"PR"	Reply:	"R 247.5982 kPa a"
Command:	"PR"				
Reply:	"R 247.5982 kPa a"				
See Also	"READYCK", "SR", "DP", "PRHI", "PRLO". "ALLR"				

<b>PRHI</b>					
Purpose	Read the last measured upstream absolute pressure ( <i>tare</i> corrected).				
Syntax	"PRHI"				
Remarks	The current upstream pressure value (corrected for <i>tare</i> ) is returned in the current pressure unit of measure.				
Example	<table border="0"> <tr> <td>Command:</td> <td>"PRHI"</td> </tr> <tr> <td>Reply:</td> <td>"247.56 kPaa"</td> </tr> </table>	Command:	"PRHI"	Reply:	"247.56 kPaa"
Command:	"PRHI"				
Reply:	"247.56 kPaa"				
See Also	"DP", "PR", "PRLO" . "ALLR"				

<b>PRLO</b>					
Purpose	Read the last measured downstream absolute pressure ( <i>tare</i> corrected).				
Syntax	"PRLO"				
Remarks	The current downstream pressure value (corrected for <i>tare</i> ) is returned in the current pressure unit of measure.				
Example	<table border="0"> <tr> <td>Command:</td> <td>"PRLO"</td> </tr> <tr> <td>Reply:</td> <td>"224.67 kPaa"</td> </tr> </table>	Command:	"PRLO"	Reply:	"224.67 kPaa"
Command:	"PRLO"				
Reply:	"224.67 kPaa"				
See Also	"DP", "PR", "PRHI" . "ALLR"				

<b>PUNIT(=)</b>		
Purpose	Read or set the pressure display unit of measure.	
Syntax	"PUNIT=unit"	
Defaults	"PUNIT"	
Arguments	unit:	The text corresponding to the pressure unit of measure. The pressure unit protocol is the same as the protocol used for front panel entries and displays.
Remarks	This command determines what unit of measure is used to display pressure.	
Example	Command:	"PUNIT=KPA"
	Reply:	"kPa a"
Errors	ERR# 7:	The unit is invalid.
See Also	<a href="#">&lt;8PRESU&gt;</a>	

<b>PURGE(=)</b>		
Purpose	Read the progress of or start a purge cycle. Not available on a molbox2-S.	
Syntax	"PURGE=period" "PURGE"	
Arguments	Period:	The period of time over which to purge (1.. 999 seconds). "0" aborts the purge cycle and returns to normal operation.
Remarks	<p>The purge cycle takes the specified time period to complete. The PURGE command is used to first start the purge cycle, and then to query how many seconds are left or if the cycle is complete. While the purge cycle is executing, a 'b' ("busy") will appear in the 3rd character position of the "FR" and the "SR" command replies. The "ABORT" command can also be used to abort a purge cycle.</p> <p>The "PURGE" command must be completed or aborted using the "ABORT" command before performing another operation.</p>	
Example	Command:	"PURGE=30"
	Reply:	"30 sec"
	Command:	"PURGE"
	Reply:	"12 sec" (purge cycle has 12 sec left)
	Reply:	"OK"(purge cycle is complete)
Errors	ERR# 6:	The argument is invalid.
See Also	<a href="#">&lt;2Purge&gt;</a> , "SR"; "ABORT"	

<b>RANGE</b>		
Purpose	Read the range designation of the active molbloc.	
Syntax	"RANGE"	
Remarks	The range designation of the active molbloc is returned in the flow units used to define the range. Note that the effective molbloc range is dependent on the gas being flowed and the molbloc pressure dependent calibration type. Do not assume the usable range is equal to the range designation.	
Example	Command:	"RANGE"
	Reply:	"10.00 sccm"
See Also	<a href="#">molbloc-S</a> , <a href="#">&lt;1molbloc&gt;</a> , <a href="#">Table 44 "MOLBLOC", "DEVICE=", "GASCALS"</a>	

<b>RATE</b>		
Purpose	Read the next available rate of change of flow.	
Syntax	'RATE'	
Remarks	The next available rate change of flow in the current flow unit of measure per second is returned.	
Example	Command:	"RATE"
	Reply:	"-0.01 sccm/s"
See Also	<a href="#">&lt;1Rate&gt;</a>	

<b>RE</b>		
Purpose	Read the value of Reynolds number representing the current flow through the molbloc as calculated by the molbox2.	
Syntax	"RE"	
Remarks	The Reynolds number varies with the molbloc flow.	
Example	Command:	"RE"
	Reply:	"82.342"
See Also	<a href="#">[P&amp;T] (Pressure and Temperature)</a>	

<b>RES(=)</b>	
Purpose	Read or set the local flow display resolution.
Syntax	"RES= <i>n</i> " "RES"
Default	"RES=0.001%"
Arguments	<i>n</i> : Resolution in %FS (1% - 0.001%)
Remarks	The molbox2's front panel resolution can be specified with this command. The resolution of remote flow measurement replies are always 0.0001% FS.
Example	Sent: "RES=.01" Query reply: "0.010%"
Errors	ERR# 6: The argument was out of bounds.
See Also	<a href="#">[RES]</a>

<b>READYCK(=)</b>	
Purpose	Read or set a flag that is cleared by a <i>Not Ready</i> condition.
Syntax	"READYCK=1" "READYCK"
Defaults	"READYCK=1"
Remarks	<p>The internal ready check flag is cleared whenever the molbox2 reaches a <i>Not Ready</i> (NR) condition. The "READYCK" command will return the status of this flag. This flag can be set only by sending the "READYCK=1" command while the molbox2 is in a <i>Ready</i> (&lt;*&gt;) condition. If you send the "READYCK=1" command when the molbox2 is in a <i>Not Ready</i> (NR) condition, the reply will be "READYCK=0".</p> <p>If you set READYCK=1 when the molbox2 achieves a <i>Ready</i> (R) condition, you can use READYCK later to determine if a <i>Not Ready</i> (NR) condition has occurred. If NR has occurred, READYCK will return "0". If NR has not occurred, READYCK will return "1".</p>
Example	Command: "READYCK=1" (Set the flag) Reply: "READYCK=1" Command: "READYCK"(Query for flag status) Reply: "READYCK=1" (Has been ready since setting flag)
Errors	ERR# 6: The argument is not a 1.
See Also	<a href="#">Flow Ready/Not Ready Indication</a> , "SR"

<b>REMOTE</b>					
Purpose	Enable remote local lockout operation.				
Syntax	"REMOTE"				
Remarks	A REMOTE command deactivates the front panel. All front panel controls except  will be disabled. The REMOTE command can only be canceled by a LOCAL command or by turning OFF the molbox2 power then re-applying it.				
Example	<table border="0"> <tr> <td>Command:</td> <td>"REMOTE"</td> </tr> <tr> <td>Reply:</td> <td>"REMOTE"</td> </tr> </table>	Command:	"REMOTE"	Reply:	"REMOTE"
Command:	"REMOTE"				
Reply:	"REMOTE"				
See Also	"LOCAL"				

<b>RESET</b>					
Purpose	Reset the molbox2 to the default operating parameters.				
Syntax	"RESET"				
Remarks	The RESET command can be given to return certain molbox2 settings to a default state. This reset corresponds to the RESET - SETS function from the front panel. The reset process can take up to 10 seconds to complete, so the user must wait this time interval before attempting to communicate to the molbox2 again.				
Example	<table border="0"> <tr> <td>Command:</td> <td>"RESET"</td> </tr> <tr> <td>Reply:</td> <td>"RESET"</td> </tr> </table>	Command:	"RESET"	Reply:	"RESET"
Command:	"RESET"				
Reply:	"RESET"				
See Also	<a href="#">&lt;1reset&gt;</a>				

<b>SN</b>					
Purpose	Read the serial number of the molbox2.				
Syntax	"SN"				
Remarks	Each molbox2 is serialized. This serial number is also imprinted on the product label on the bottom of the molbox2 and is displayed in the power up introductory screen.				
Example	<table border="0"> <tr> <td>Command:</td> <td>"SN"</td> </tr> <tr> <td>Reply:</td> <td>"SN"</td> </tr> </table>	Command:	"SN"	Reply:	"SN"
Command:	"SN"				
Reply:	"SN"				
See Also	<a href="#">&lt;3ID&gt;</a>				

<b>SR</b>													
Purpose	Read the next available ready status.												
Syntax	"SR"												
Remarks	<p>The current <i>Ready/Not Ready</i> status can be read directly using this command. If the reply is "NR" then the flow is <i>Not Ready</i> within the limits set by the stability settings, molbloc calibration flow or pressure limits. If the reply is "R" then the flow is <i>Ready</i> within the limits. The status is replied when the next flow measurement is finished.</p> <p>The third character indicates optional additional molbox status information:</p> <p>"r" molbloc flow is over the maximum Reynolds number of 1 200 allowed for a valid measurement.</p> <p>"b" molbox2 is busy with a <i>tare</i>, leak check or purge cycle which does not allow normal operation.</p> <p>"a" molbox2 is currently executing an averaging cycle.</p> <p>"P" molbloc-S BPR is too high or molbloc pressure exceeds molbloc calibration pressure limits by 10kPa or more (always causes a <i>Not Ready</i> condition).</p> <p>"F" Measured flow exceeds molbloc calibration flow limit by 5% or more (always causes a <i>Not Ready</i> condition).</p>												
Example	<table style="width: 100%; border-collapse: collapse;"> <tr> <td style="width: 15%; border-right: 1px solid black;">Command:</td> <td>"SR "</td> </tr> <tr> <td style="border-right: 1px solid black;">Reply:</td> <td>"R " (Flow measurement is ready)</td> </tr> <tr> <td style="border-right: 1px solid black;">Reply:</td> <td>"NR " (Flow measurement is not ready)</td> </tr> <tr> <td style="border-right: 1px solid black;">Reply:</td> <td>"R a" (average cycle is executing)</td> </tr> <tr> <td style="border-right: 1px solid black;">Reply:</td> <td>"R b" (tare, leak check or purge cycle is executing)</td> </tr> <tr> <td style="border-right: 1px solid black;"></td> <td>"NRP" (BPR is too high for a valid measurement)</td> </tr> </table>	Command:	"SR "	Reply:	"R " (Flow measurement is ready)	Reply:	"NR " (Flow measurement is not ready)	Reply:	"R a" (average cycle is executing)	Reply:	"R b" (tare, leak check or purge cycle is executing)		"NRP" (BPR is too high for a valid measurement)
Command:	"SR "												
Reply:	"R " (Flow measurement is ready)												
Reply:	"NR " (Flow measurement is not ready)												
Reply:	"R a" (average cycle is executing)												
Reply:	"R b" (tare, leak check or purge cycle is executing)												
	"NRP" (BPR is too high for a valid measurement)												
See Also	"FA", "FR", "READYCK", "SS", "TARESET", "PURGE", "LEAKCK", "ALLR"												

<b>SS(%)</b>	
Purpose	Read or set the flow stability required for a <i>Ready</i> condition to occur (flow unit/s).
Syntax	"SS=stab" "SS" "SS%=stab%" "SS%"
Defaults	"SS=0.1 sccm"
Arguments	stab:           The flow stability in flow unit/sec. stab%:          The flow stability in % FS of the active molbloc.
Remarks	The stability setting determines whether the flow is <i>ready</i> or <i>not ready</i> . Stability is set in terms of flow or % FS. It is always stored in terms of flow, so the % FS value will change if the molbloc range changes. If the rate of change of flow is greater than the current setting, then the status is <i>Not Ready</i> .
Example	Command:       "SS=.2" Reply:           "0.20 sccm" Command:       "SS%=.1" Reply:           "0.1000 %"
Errors	ERR# 6:        The argument is invalid.
See Also	<a href="#">Flow Ready/Not Ready Indication, &lt;2stab&gt;</a> , "READYCK", "SR"

<b>STDRES(=)</b>	
Purpose	Read or set the PRT measurement system auto-calibration reference resistor values.
Syntax	"STDRES=R100, R110" "STDRES"
Defaults	"STDRES = 100.0000, 110.0000"
Arguments	R100:           The actual value of the 100Ω reference resistor. R110:           The actual value of the 110Ω reference resistor.
Remarks	These values are stored in the molbox's factory data area, and should not be routinely changed due to a limitation of the number of changes allowed (100,000 changes) before the factory data area is subject to failure. Use the channel dependent "TCAL" command for adjusting the temperature calibration.
Example	Sent:            "STDRES=100.002, 109.998" Reply:           " 100.0020 Ohms, 109.9980 Ohms"
See Also	<a href="#">OHMIC Measurement [Temperature] System Verification</a> , "TCAL"

<b>TARE</b>					
Purpose	Read the current <i>tare</i> conditions and the current <i>tare</i> . Not available on a molbox2-S.				
Syntax	"TARE"				
Remarks	<p>Set the molbox2 valves to the <i>tare</i> condition (see "TARESETUP") and check the <i>tare</i> conditions using this command before taring the internal transducers (see "TARESET").</p> <p>The returned data will allow the user to determine if the current conditions will allow a valid <i>tare</i>. The reply contains three fields which are separated by commas.</p> <p>The first field starts with an "R" if the system is ready to <i>tare</i> or else an "NR". The "R" must be present to <i>tare</i> the transducers. The system is ready to <i>tare</i> only if the current difference in pressure [Pa] between the up and down stream RPTs without <i>tare</i> is below 3,000 Pa. The actual pressure rate of change in Pa/sec follows this text.</p> <p>The second field displays the current difference in pressure [Pa] between the up and down stream RPTs without <i>tare</i>. The third field shows the last <i>tare</i> value. All returned values are in Pascal [Pa]. You cannot be in A+B or A/B modes when taring.</p> <p>The normal order of remote commands for a <i>tare</i> operation:</p> <p>"TARESETUP=UP" or "TARESETUP=DN" configures the molbox2 for a <i>tare</i>.</p> <p>"TARE" queries the molbox2 for current conditions until it is ready for <i>tare</i>.</p> <p>"TARESET" <i>tare</i>s the molbox2 when the "TARE" query has shown it is ready.</p> <p>"TARESETUP=OFF" returns the molbox2 to normal measurement mode.</p>				
Example	<table border="0"> <tr> <td>Command:</td> <td>"TARE"</td> </tr> <tr> <td>Reply:</td> <td>"R 0 Pa/s, 115.2 Pa, 108.1 Pa"</td> </tr> </table>	Command:	"TARE"	Reply:	"R 0 Pa/s, 115.2 Pa, 108.1 Pa"
Command:	"TARE"				
Reply:	"R 0 Pa/s, 115.2 Pa, 108.1 Pa"				
Errors	<table border="0"> <tr> <td>ERR# 6:</td> <td>An argument is invalid.</td> </tr> <tr> <td>ERR# 52:</td> <td>Cannot tare in A+B or A/B mode.</td> </tr> </table>	ERR# 6:	An argument is invalid.	ERR# 52:	Cannot tare in A+B or A/B mode.
ERR# 6:	An argument is invalid.				
ERR# 52:	Cannot tare in A+B or A/B mode.				
See Also	< <a href="#">1tare</a> >, "TARESET", "TARESETUP"				

<b>TARESETUP(=)</b>		
Purpose	To prepare the molbox2 to be <i>tared</i> and to return the unit to normal operation after a <i>tare</i> has been completed. Not available on a molbox2-S.	
Syntax	"TARESETUP=mode "TARESETUP"	
Defaults	"TARESETUP=OFF"	
Arguments	mode:	<p>"OFF". Allows normal operation of the molbox2.</p> <p>"UP". Connects both of the absolute RPTs to the upstream pressure.</p> <p>"DN". Connects both of the absolute RPTs to the downstream pressure.</p>
Remarks	<p>Before the molbox2 can be <i>tared</i>, the "TARESETUP" command <b>must</b> be used to configure the internal RPT connections properly. After the <i>tare</i> operation is complete, the "TARESETUP" command <b>must</b> again be used to restore the molbox2 to normal operation. The "ABORT" command can also return operation to normal.</p> <p>The normal order of remote commands for a <i>tare</i> operation:</p> <p>"TARESETUP=UP" or "TARESETUP=DN" configures the molbox2 for a <i>tare</i>.</p> <p>"TARE" queries the molbox2 for current conditions until it is ready for <i>tare</i>.</p> <p>"TARESET" <i>tare</i>s the molbox2 when the "TARE" query has shown it is ready.</p> <p>"TARESETUP=OFF" returns the molbox2 to normal measurement mode.</p>	
Example	Command:	"TARESETUP=UP"
	Reply:	"UP"
Errors	ERR# 6:	An argument is invalid.
	ERR# 52:	Cannot tare in A+B or A/B mode.
See Also	< <a href="#">1tare</a> >, "TARE", "TARESET"; "ABORT"	

<b>TARESET(=)</b>							
Purpose	To automatically <i>tare</i> the upstream and downstream RPT or set the <i>tare</i> to a user defined value. Not available on a molbox2-S.						
Syntax	"TARESET=tare "TARESET"						
Defaults	"TARESET=0"						
Arguments	tare:            The <i>tare value</i> (-9999 to 9999 Pa).						
Remarks	<p>"TARESET" will automatically <i>tare</i> the molbox2 only if the <i>tare</i> results are within the limits given (see the "TARE" command). Use the "TARESETUP" command to prepare the unit to be <i>tared</i>, and the "TARE" command to check if conditions are valid. After you have completed taring the unit, use the "TARESETUP=OFF" command or the "ABORT" command to return the unit to normal operating conditions. You can also manually set the tare value using the "TARESET=tare" command. All pressure values are always in Pascal [Pa]. While the <i>tare</i> cycle is executing, a 'b' ("busy") will appear in the third character position of the "FR" and the "SR" command replies.</p> <p>The normal order of remote commands for a <i>tare</i> operation:</p> <p>"TARESETUP=UP" or "TARESETUP=DN" configures the molbox2 for a <i>tare</i>.</p> <p>"TARE" queries the molbox2 for current conditions until it is ready for <i>tare</i>.</p> <p>"TARESET" <i>tare</i>s the molbox2 when the "TARE" query has shown it is ready.</p> <p>"TARESETUP=OFF" returns the molbox2 to normal measurement mode.</p> <p><b>NOTE:</b> This command typically takes 5 to 7 seconds to complete if performing a <i>tare</i> (no arguments given).</p>						
Example	<table border="0"> <tr> <td>Command:</td> <td>"TARESET"</td> </tr> <tr> <td>Reply:</td> <td>"66 Pa"</td> </tr> <tr> <td>Reply:</td> <td>"66 Pa, 7 Pa"</td> </tr> </table>	Command:	"TARESET"	Reply:	"66 Pa"	Reply:	"66 Pa, 7 Pa"
Command:	"TARESET"						
Reply:	"66 Pa"						
Reply:	"66 Pa, 7 Pa"						
Errors	<table border="0"> <tr> <td>ERR# 6:</td> <td>An argument is invalid.</td> </tr> <tr> <td>ERR# 25:</td> <td>The <i>tare values</i> exceed the <i>tare</i> limit of 3,000 Pa.</td> </tr> <tr> <td>ERR# 52:</td> <td>Cannot tare in A+B or A/B mode.</td> </tr> </table>	ERR# 6:	An argument is invalid.	ERR# 25:	The <i>tare values</i> exceed the <i>tare</i> limit of 3,000 Pa.	ERR# 52:	Cannot tare in A+B or A/B mode.
ERR# 6:	An argument is invalid.						
ERR# 25:	The <i>tare values</i> exceed the <i>tare</i> limit of 3,000 Pa.						
ERR# 52:	Cannot tare in A+B or A/B mode.						
See Also	< <a href="#">1tare</a> >, "TARE", "TARESETUP", "ABORT"						

<b>TCAL(=)</b>		
Purpose	Read or set the molbox2 temperature calibration for the active channel	
Syntax	"TCAL= <i>adder, mult, date</i> " "TCAL"	
Arguments	<i>adder</i> :	Temperature adder in the current temperature units.
	<i>mult</i> :	Temperature multiplier.
	<i>date</i> :	Date (YYYYMMDD)
Remarks	The temperature calibration for active channel is applied to the displayed molbloc temperature.	
Example	Command:	"TCAL=0.25, 1.003,20090226"
	Reply:	"0.250, 1.0030,20090226"
Errors	ERR# 2:	The <i>date</i> argument is invalid
See Also	<a href="#">molbloc-S Operation</a> , "TUNIT", "DEVICE", "STDRES"	

<b>TEMP</b>		
Purpose	Read the temperature of the active molbloc in the current unit of measure.	
Syntax	"TEMP"	
Remarks	The molbloc temperature is returned in the current temperature units. The average temperature, upstream temperature and downstream temperature is returned (in that order). An error will be returned if there is a problem reading the molbloc PRTs.	
Example	Command:	"TEMP"
	Reply:	"17.85 C, 17.84 C, 17.86 C"
Errors	ERR# 37:	There is an error in the molbox2 PRT measurement.
See Also	<a href="#">OHMIC Measurement [Temperature] System Verification, [P&amp;T] (Pressure and Temperature)</a> "TUNIT", "OHMS", "TCAL"	

<b>TIME(=)</b>		
Purpose	Read or set the internal clock time.	
Syntax	"TIME" "TIME=hh:mm:m"	
Arguments	hh:mmxs:	The time to set in the format where hh is the hours from 1 to 12, mm is the minutes from 1 to 59 followed by "am" or "pm".
Example	Command:	"TIME=1:22am"
	Reply:	"01:22am"
Errors	ERR# 7:	The time given is invalid.
See Also	<a href="#">&lt;3Time&gt;</a>	

<b>TOTAL(=)</b>		
Purpose	Read the progress of or start a new totalize cycle.	
Syntax	"TOTAL=period" "TOTAL"	
Arguments	period:	The period to totalize 00:00:01 to 99:59:59 (HH:MM:SS). "0" stops the totalize cycle before it is complete.
Remarks	<p>The totalizing cycle accumulates the total mass or volume flowed over a set period, or the user can stop the cycle early if desired to use a shorter period than specified.</p> <p>The reply to a "TOTAL" query provides the current total, and the elapsed time period in the HH:MM:SS format. The cycle is complete when the total flow is preceded by 'R' (<i>Ready</i>). If the unit is actively totalizing, an "NR" (<i>Not Ready</i>) precedes the total flow.</p>	
Example	Command:	"TOTAL=00:10:00"
	Reply:	"NR 0.0000 ucc, 00:00:00" (new cycle has started)
	Command:	"TOTAL"
	Reply:	"NR 5.2347 ucc, 00:08:21" (cycle has run 8 min, 21 sec)
	Reply:	"R 6.2634 ucc, 00:10:00" (cycle is complete)
	Command:	"TOTAL=0"
	Reply:	"R 5.2347 ucc, 00:08:21" (cycle has completed early)
Errors	ERR# 6:	The argument is invalid.
See Also	<a href="#">&lt;4Total&gt;</a> ( <i>Totalizer</i> )	

<b>TUNIT</b>		
Purpose	Read or set the molbox2 temperature unit of measure.	
Syntax	"TUNIT=unit" "TUNIT"	
Arguments	unit:	'C' for Celsius or 'F' for Fahrenheit.
Remarks	The temperature unit is used for reporting the molbloc temperature, and for setting various other temperature settings.	
Example	Command:	"TUNIT"
	Reply:	"C"
Errors	ERR# 6:	The unit argument is invalid.
See Also	<a href="#">&lt;9TEMPU&gt;</a> , "TEMP"	

<b>UDU(=)</b>		
Purpose	Read or set the user definable pressure unit.	
Syntax	"UDU" "UDU=text, coef"	
Arguments	text:	The text to use to identify the unit. It can be up to four characters wide. This will be the text used to specify the unit if selecting it remotely, and that appears on the molbox2.
	coef:	The coefficient to convert Pascal [Pa] to the user unit. The pressure (in Pa) will be multiplied by this coefficient before being displayed.
Defaults	"UDU=UNIT, 1"	
Example	Command:	"UDU=Bar2, .00001"
	Reply:	"Bar2, 0.000010"
Errors	ERR# 2:	The text argument is longer than four characters.
	ERR# 6:	The coef argument is invalid.
See Also	<a href="#">&lt;8PRESU&gt;</a> , "PUNIT"	

<b>UL(=)</b>	
Purpose	Read or set the upper limit for the internal pressure transducers.
Syntax	"UL=upperlimit" "UL"
Defaults	"UL=630.00 kPa"
Arguments	upperlimit:    The upper limit in the current pressure units (0 to 500 kPa).
Remarks	The upper limit sets the point in which the molbox2 reacts to protect the internal transducers; It is in the current pressure units.
Example	Command:    "UL=350" Reply:        "350.000 kPa"
Errors	ERR# 6:      The upperlimit argument is invalid.
See Also	<a href="#">&lt;3UL&gt;</a>

<b>UNCEXP</b>	
Purpose	Read the measurement uncertainty of the current molbloc in the current gas.
Syntax	"UNCEXP"
Remarks	Only available when a NIST model capable molbloc is connected (L10, S10), otherwise returns "ERR#37" Incompatible Device. For a gas the molbloc is actually calibrated in with return the Standard or Premium uncertainty. For a gas the molbloc is NOT calibrated in, but supported by Fluke accreditation, will return an uncertainty of 0.5 % of reading or 0.05 % FS. For a gas the molbloc is NOT calibrated in, and Fluke has no direct experience with the gas, will return the RSS combination of molbloc uncertainty with the gas density and viscosity uncertainties, but not less than 0.5 % of reading or 0.05 % FS. Custom gases added with incomplete uncertainty will return "ERR#37"
Example	Command:    "UNCEXP"
	Reply:        {calibrated, accredited, traceable, "Premium" uncertainty} "Ar, UxRdg 0.125, UxFS 0.013"
	Reply:        {uncalibrated, accredited, traceable} "Ar, UxRdg 0.500, UxFS 0.050"
	Reply:        {uncalibrated, not accredited, traceable} "O2, UxRdg 2.00, UxFS 0.20, Udens 0.10, Uvisc 2.00"
Errors	"ERR#37" Incompatible Device
See Also	"GASCALS"

<b>USERCAL(=)</b>		
Purpose	Read or set the user flow measurement adjustment.	
Syntax	"USERCAL= <i>adder</i> , <i>mult</i> " "USERCAL"	
Defaults	"USERCAL=0, 1"	
Arguments	<i>Adder</i> :	The flow <i>adder</i> in the current flow unit and gas type (0 to FS).
	<i>Mult</i> :	The flow <i>multiplier</i> (0.1 to 2).
Remarks	The user definable adjustment lets the user modify the measured flow. The <i>adder</i> and <i>multiplier</i> are separated by a comma. The <i>adder</i> is in the current flow unit. This adjustment will be applied to any molbloc connected to the molbox2.	
Example	Command:	"USERCAL=.58,.995"
	Reply:	"0.58 sccm, 0.995000"
Errors	ERR# 6:	The <i>adder</i> or <i>multiplier</i> argument is invalid.
See Also	<a href="#">&lt;3ADJ&gt;</a>	

<b>UTEMP</b>		
Purpose	Read or set the temperature reference used for the volumetrically based mass flow unit with user defined reference temperature.	
Syntax	"UTEMP=temp" "UTEMP"	
Defaults	"UTEMP=0" (°C)	
Arguments	Temp:	The reference temperature in the current temperature unit of measure.
Remarks	This temperature reference is used by the user defined units.	
Example	Command:	"UTEMP=20"
	Reply:	"20.00 C"
See Also	<a href="#">Mass Flow vs. Volume Flow, Volume Flow Units (vfm)</a> , "FUNIT", "TUNIT"	

<b>VALVE(=)</b>	
Purpose	This command is obsolete and should <b>not be used</b> in new designs. The TARESETUP and PURGE commands should be used instead for special valve operations.
Syntax	"VALVE=xxx" "VALVE"
Arguments	xxx:            The driver bitfield.
Remarks	This command is obsolete.
Example	Command:        "VALVE=5" Reply:            "5"
Errors	ERR# 6:         The xxx argument is not between 0 and 255.
See Also	"TARESETUP", "PURGE"

<b>VER</b>	
Purpose	Read the molbox2 version.
Syntax	"VER"
Remarks	The software version of the molbox2 can be read. This is useful for checking for the presence of the molbox2 and for reference purposes.
Example	Command:        "VER" Reply:            "molbox2 Ver5.10"

<b>VLM(=)</b>	
Purpose	Read or set the volume flow unit of measure pressure temperature conditions.
Syntax	"VLM=pres(,temp)" "VLM"
Defaults	"VLM=101.325 kPaa, 20°C"
Arguments	pres:            The user defined pressure in the current pressure unit. Temp:            The user defined temperature in the current temperature unit. If this field is omitted, and just the pressure is given, then the molbloc temperature will be used as temperature.
Remarks	The flow volume units "ccm", "lm", "lh", "m3m", "m3h", "cfm" and "cfh" require pressure and a temperature conditions to be specified by the user.
Example	Command:        "VLM=200" Reply:            "200.00 kPaa" (molbloc temp will be used) Command:        "VLM=200, 15" Reply:            "200.00 kPaa, 15°C" (user defined temp will be used)
Errors	ERR# 6:         One of the arguments is invalid.
See Also	<a href="#">Mass Flow vs. Volume Flow, Volume Flow Units (vfm)</a> "FUNIT"

<b>VIN</b>					
Purpose	Read the MFC measurement voltage if in voltage mode.				
Syntax	"VIN"				
Remarks	The optional MFC interface can measure voltage sent from an MFC. The molbox2 must be in voltage mode before this can be done. The returned data is always in "v".				
Example	<table border="1"> <tr> <td>Command:</td> <td>"VIN"</td> </tr> <tr> <td>Reply:</td> <td>"1.982 V"</td> </tr> </table>	Command:	"VIN"	Reply:	"1.982 V"
Command:	"VIN"				
Reply:	"1.982 V"				
Errors					
See Also	<a href="#">[MFC] (Optional), MFC Control Function-MFC Connector</a> , "MFCCH", "VOUT(=)"				

<b>VOUT(=)</b>							
Purpose	Send a voltage to the MFC if in voltage mode.						
Syntax	"VOUT=voltage" "VOUT"						
Defaults	"VOUT=0"						
Arguments	voltage: The voltage to be sent to the MFC (0 to 5.5 V).						
Remarks	The optional MFC interface can set a voltage sent to an MFC. The molbox2 must be in voltage mode before this can be done (see the "MFCCH" command). The data is always in Volts. This command does not change the regulation target set point for the MFC.						
Example	<table border="1"> <tr> <td>Command:</td> <td>"VOUT=3"</td> </tr> <tr> <td>Reply:</td> <td>"3.000 V"</td> </tr> </table>	Command:	"VOUT=3"	Reply:	"3.000 V"		
Command:	"VOUT=3"						
Reply:	"3.000 V"						
Errors	<table border="1"> <tr> <td>ERR# 6:</td> <td>The Volts argument is invalid.</td> </tr> <tr> <td>ERR# 10:</td> <td>The MFC option is not installed or is not enabled.</td> </tr> <tr> <td>ERR# 15:</td> <td>The molbox2 is not in current mode.</td> </tr> </table>	ERR# 6:	The Volts argument is invalid.	ERR# 10:	The MFC option is not installed or is not enabled.	ERR# 15:	The molbox2 is not in current mode.
ERR# 6:	The Volts argument is invalid.						
ERR# 10:	The MFC option is not installed or is not enabled.						
ERR# 15:	The molbox2 is not in current mode.						
See Also	<a href="#">[MFC] (Optional), MFC Control Function Adjustment</a> , "MFCCH", "VIN"						

<b>VSENSE</b>					
Purpose	Read the voltage sensed at the DUT set terminal.				
Syntax	"VSENSE"				
Remarks	The optional MFC interface uses a voltage sense line to measure the voltage being sent to an external MFC at the MFC. This sense voltage is used to re-adjust the voltage sent to the MFC to compensate for line losses.				
Example	<table border="1"> <tr> <td>Command:</td> <td>"VSENSE"</td> </tr> <tr> <td>Reply:</td> <td>"3.002 V"</td> </tr> </table>	Command:	"VSENSE"	Reply:	"3.002 V"
Command:	"VSENSE"				
Reply:	"3.002 V"				
Errors					
See Also	<a href="#">[MFC] (Optional), MFC Control Function-MFC Connector</a> , "MFCCH", "VIN", "VOUT"				

<b>VSUPPLY</b>					
Purpose	Read the current $\pm 15$ Volt MFC supply voltage.				
Syntax	"VSUPPLY"				
Remarks	The optional MFC interface provides a $\pm 15$ Volt supply. These two measurements are referenced to the MFC supply common, and are sensed in the molbox2.				
Example	<table border="1"> <tr> <td>Command:</td> <td>"VSUPPLY"</td> </tr> <tr> <td>Reply:</td> <td>"+14.982 V, -15.231 V"</td> </tr> </table>	Command:	"VSUPPLY"	Reply:	"+14.982 V, -15.231 V"
Command:	"VSUPPLY"				
Reply:	"+14.982 V, -15.231 V"				
See Also	<a href="#">[MFC] (Optional), MFC Control Function-MFC Connector</a> , "MFCCH", "VIN", "VOUT"				

<b>VVALTEST</b>					
Purpose	Read the voltage at the optional MFC interface valve test input.				
Syntax	"VVALTEST"				
Remarks	The optional MFC interface provides an input to measure the MFC valve test voltage. This measurement is referenced to the MFC -15 Volt supply.				
Example	<table border="1"> <tr> <td>Command:</td> <td>"VVALTEST"</td> </tr> <tr> <td>Reply:</td> <td>"5.32 V"</td> </tr> </table>	Command:	"VVALTEST"	Reply:	"5.32 V"
Command:	"VVALTEST"				
Reply:	"5.32 V"				
See Also	<a href="#">[MFC] (Optional), MFC Control Function-MFC Connector</a> , "MFCCH", "VIN", "VOUT"				

<b>ZOFFSET:HI(=) and ZOFFSET:LO(=)</b>	
Purpose	Read or set the AutoZ pressure offset ( $P_{offset}$ ) for the high ("HI") or low ("LO") RPT.
Command:	"ZOFFSET:HI = <i>offset</i> " "ZOFFSET:LO = <i>offset</i> "
Query:	"ZOFFSET:HI" "ZOFFSET:LO"
Defaults	"ZOFFSET:HI = 0.0" "ZOFFSET:LO = 0.0"
Arguments	offset:           The RPT pressure offset ("Poffset") in Pa.
Remarks	The pressure offset ( $P_{offset}$ ) for the specified RPT (HI or Lo) can be accessed with this command. Using this program message overwrites the current offset, so caution must be used. Changes made using this program message take effect immediately.
Example	Sent:            " <b>ZOFFSET:LO=2.1</b> " Reply:           " <b>  2.10 Pa</b> "
Errors	ERR# 6:        One of the arguments is out of range.
See Also	<a href="#">&lt;4AutoZ&gt;</a> , "AUTOZERO" command

## Status System

The status system includes the status reporting system which reports general molbox2 events. The user can select which molbox2 events cause a status change event. These events are then reported to the status system (bit7 and bit3 of the status byte register), which also must be configured for the STATUS subsystem to generate the service requests described in [Status Reporting System](#), Status Reporting System.

There are two 16-bit event registers that make up the top layer of the status subsystem. The OPERATION status register handles conditions that are normal for the molbox2. The QUESTIONABLE status register handles events that could cause measurements to be made under questionable conditions.

Other registers layered below these two registers provide the structure necessary to handle the two RPT channels and to enable the events and event transitions. Bit15 of all of these registers is not used because bit15 represents a sign bit on some computer systems.

## Status Reporting System

The molbox2 status reporting system tracks and reports system status and errors. The status subsystem is layered under and reports to the status reporting system. It follows the model of the IEEE Std 488.2 and works for the COM1 and the IEEE-488 port with slight differences. The molbox2 can be programmed to respond to various status conditions by asserting the SRQ of the IEEE-488 interface. The COM1 port cannot be supported in this manner, so polling must be used.

## Status Byte Register

The molbox2 contains an 8-bit status byte register that reflects the general status of the molbox2. See [Table 28](#).

**Table 28. Status Byte Register**

<b>OPER</b> (128)	<b>RQS/MSS</b> (64)	<b>ESB</b> (32)	<b>MAV</b> (16)	<b>N/A</b> (8)	<b>ERROR</b> (4)	<b>N/A</b> (2)	<b>RSR</b> (1)
----------------------	------------------------	--------------------	--------------------	-------------------	---------------------	-------------------	-------------------

This register is affected by the molbox2 reply output queue, the error queue, the Standard Event Status register, the Ready Event Status register and the STATUS subsystem. See [Figure 14](#).

**Figure 14. Status Byte Register**

("\*STB?" or "\*SRE n")

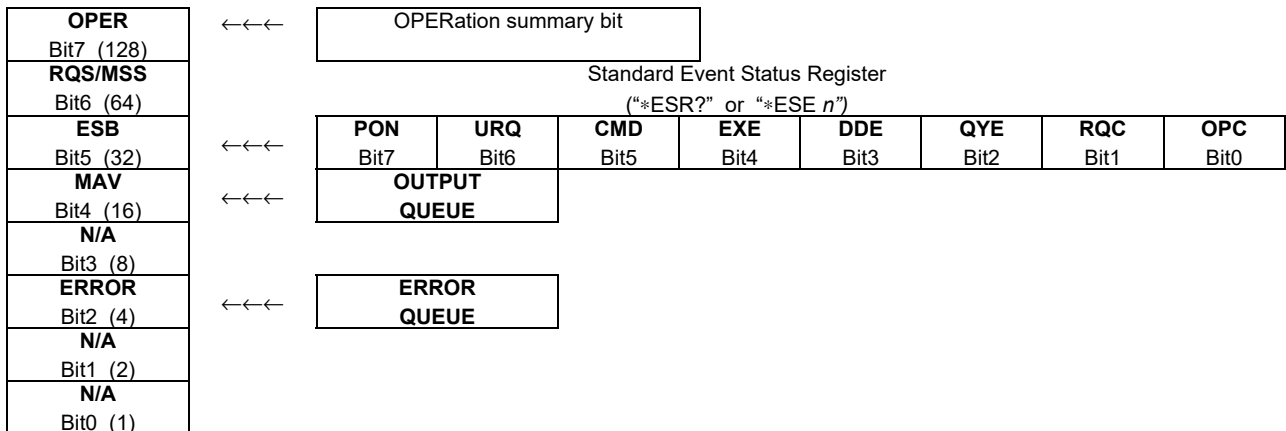

The status byte register can be read using the "\*STB?" query, or by performing a serial poll on the IEEE-488 bus. If you read this using a serial poll then bit 6 is the RQS. If the "\*STB?" query is used, then bit 6 is the MSS bit. All other bits are common to both types of query.

Each of these status bits can cause a SRQ to occur. The Service Request Enable Register ("\*SRE" program message) determines which of these flags are able to assert the SRQ line. This enable register has a matching set of bits that each will enable the designated bit to cause a SRQ, except for the RQS/MSS bit(s) which cannot cause a SRQ. If you set this register to 20 (\$14 hex), an SRQ occurs if the MAV or the ERROR bit are set. The description of these bits are given as:

- **OPER:** OPERational event register summary bit (Bit 7)  
This bit is not supported by the molbox2.
- **RQS:** Requested Service (Bit 6)  
Indicates that the SRQ line of the IEEE-488 interface has been asserted by the molbox2. This bit is cleared when a serial poll is performed on the molbox2, and is a part of the status byte register when read with a serial poll. This bit does not apply if the COM1 port is in use.
- **MSS:** Master Summary Status (Bit 6)

Indicates that an event or events occurred that caused the molbox2 to request service from the Host, much like the RQS bit. Unlike the RQS bit, it is READ ONLY and can be only cleared when the event(s) that caused the service request are cleared.

- **ESB:** Event Summary Bit (Bit 5)

Indicates if an enabled bit in the Standard Event Status Register became set. (See [Standard Event Register](#))

- **MAV:** Message Available Bit (Bit 4)

Indicates that at least one reply message waits in the molbox2 IEEE-488 output queue.

- **ERR:** Error Queue not empty (Bit 2)

Indicates that at least one command error message waits in the molbox2 IEEE-488 error message queue. Use the "SYSTEM:ERRor?" query to get this message.

### Standard Event Register

The molbox2 contains an 8-bit Standard event register that reflects specific molbox2 events that are not RPT dependent. Enabled events in this register will set or clear the ESB bit of the status byte register. See [Table 29](#).

**Table 29. Standard Event Register**

<b>PON</b>	<b>URQ</b>	<b>CMD</b>	<b>EXE</b>	<b>DDE</b>	<b>QYE</b>	<b>RQC</b>	<b>OPC</b>
(128)	(64)	(32)	(16)	(8)	(4)	(2)	(1)

Read this register with the "\*ESR?" query. Each of these status bits can set the ESB bit of the status byte register which causes a SRQ to occur IF the ESB bit is enabled to do so. The Standard Event Status Enable Register ("\*ESE" program message) determines which of these flags are able to assert the ESB bit. The description of these bits are given as:

- **PON:** Power On (Bit 7)

Indicates that the molbox2 power has been cycled since the last time this bit was read or cleared.

- **URQ:** User Request (Bit 6)

Indicates that the molbox2 was set to local operation manually from the front panel by the user (pushing the ESC key).

- **CMD:** Command Error (Bit 5)

Indicates that a remote command error has occurred. A command error is typically a syntax error in the use of a correct program message.

- **EXE:** Execution Error (Bit 4)

Indicates if a remote program message cannot be processed due to device related condition.

- **DDE:** Device Dependent Error (Bit 3)  
Indicates that an internal error has occurred in the molbox2 (for example, a transducer time-out).
- **QYE:** Query Error (Bit 2)  
Indicates that an error has occurred in the protocol for program message communications. This is typically caused by a program message being sent to the molbox2 without reading a waiting reply.
- **RQC:** Request Control (Bit 1)  
This bit is not supported as the molbox2 cannot become the active controller in charge.
- **OPC:** Operation Complete (Bit 0)  
Indicates that the molbox2 has completed all requested functions

## Maintenance, Adjustments, and Calibration

### Product Overview

molbox2 features maintenance free operation. No maintenance is required other than:

- **Taring of Reference Pressure Transducers (RPTs) to zero differential for molbloc-L operation:** This function is not a separate MAINTENANCE function or automatic molbox2 activity, it is part of regular operation (see [<1tare>](#)).
- **AutoZero of Reference Pressure Transducers (RPTs):** Regular rezeroing of the RPTs absolute measurement mode to a barometric reference standard with the AutoZ function is recommended by Fluke Calibration (see [<4AutoZ>](#)).
- **Reference Pressures Transducer (RPT) Calibration:** Fluke Calibration recommend an annual recalibration cycle. See [Calibration Of Reference Pressure Transducers \(RPTS\)](#) for RPT calibration instructions.
- **Optional MFC Control Function Verification:** The stability of the MFC control function analog voltage and current measurements over time depends upon the conditions of use. Verify the MFC control function accuracy regularly. See [MFC Control Function-MFC Connector](#) for instructions.
- **Ohmic Measurement System Verification:** Fluke Calibration recommends a 5-year verification interval. See [OHMIC Measurement \[Temperature\] System Verification](#) for instructions.
- **molbloc Calibration:** molblocs can be calibrated separately from the molbox2. Fluke Calibration recommends a 1-year recalibration cycle. Calibration of a molbloc consists of a comparison of the mass flow measured by the combination of the molbloc and a calibrated molbox to a suitable mass flow standard flowing the gas for which the calibration is being done. Since the molbloc is a static, stainless steel element, characterized by proprietary calibration coefficients determined in the original factory calibration, an out of tolerance molbloc is usually considered to require repair. For facilities that require the capability to adjust molblocs to agree with their mass flow standard, CalTool for molbloc Extension to COMPASS for Flow software is available.

This section provides information on maintenance, adjustment, calibration procedures and recommended overhaul procedures.

*Note*

*Calibration, maintenance and repair services for molbox2 are offered by Fluke Calibration authorized service providers (see the warranty at the start of this manual).*

**⚠ Caution**

**Before you assume that unexpected behavior is caused by a system defect or breakdown, use this manual and other training facilities to become thoroughly familiar with molbox2 operation. For rapid assistance in specific situations and other troubleshooting information, see [Troubleshooting](#).**

**molbox2 is covered by a limited 1-year warranty (see the front of this manual). Unauthorized service or repair during the warranty period is undertaken at the risk of the owner and may cause damage that is not covered under product warranty and/or may void the product warranty.**

## Clean the Product

To clean the Product, wipe the instrument with a cloth that is lightly dampened with water or mild detergent. Do not use aromatic hydrocarbons, chlorinated solvents, or methanol based fluids.

## Product Disposal

Dispose of the Product in a professional and environmentally sound manner:

- Delete personal data on the Product before disposal.
- Remove batteries that are not integrated into the electrical system before disposal and dispose of batteries separately.
- If this Product has an integral battery, put the entire Product in the electrical waste.

## Calibration Of Reference Pressure Transducers (RPTS)

### Principle

molbox2 has two nominally identical, absolute Reference Pressure Transducers (RPTs) used to measure molbloc upstream and downstream pressure.

To calibrate an RPT, pressure from a pressure standard is applied to the RPTs at ascending and descending pressure increments over the RPT range. The pressure defined by the standard and the corresponding RPT readings are recorded at each point. After all of the pressures have been applied and recorded, adjustments are made to fit the RPT pressure readings to the standard. Fitting the readings means performing a least squares linear regression to arrive at the lowest value of the residual of errors of the transducer relative to the standard. The transducer readings are adjusted by user settable coefficients: PA (a pressure adder or offset) and PM (a pressure multiplier or span set) (see [PA and PM Coefficients](#)).

molbox2 is delivered with an interactive reference pressure transducer (RPT) calibration utility software program that steps the operator through the complete RPT calibration procedure including applying pressures, collecting data automatically, calculating new PA and PM values, previewing the results of the new calibration and activating the results of the new calibration (see the CalTool for RPTs program and documentation provided on the General Accessories disk delivered with molbox2). molbox2 also provides complete local and remote access to RPT calibration coefficients so that RPT calibrations can be performed without using CalTool software if desired (see [RPT Calibration/Adjustment Procedure Without Using CalTool for RPTs Software](#)).

**⚠ Caution**

**CalTool for RPTs software provided with the molbox2 supports the calibration process of molbox2 RPTs. The CalTool program and its manual are provided on the General Accessories Disk with the new molbox2. Most users should use CalTool software to assist in the calibration of molbox2 RPTs.**

### PA and PM Coefficients

The coefficients used to adjust RPT readings are designated PA (a pressure adder or offset) and PM (a pressure multiplier or span set). The coefficients affect the RPT reading that follows:

***Corrected reading = (uncorrected reading • PM) + PA***

*PA* is expressed in pressure (always the SI unit, Pascal [Pa]).

*PM* is dimensionless.

There are individual *PA* and *PM* values for each of molbox2's two RPTs. The *PA* and *PM* values currently in use for each RPT can be viewed in the CALIBRATION function or the *PCAL* remote command. If adjustments are necessary when you calibrate an RPT, the adjustments are made by adjusting the *PA* and *PM* values.

**⚠ Caution**

**As editing *PA* and *PM* values will change RPT calibration, they should only be edited by qualified personnel as part of the calibration process. Use Caution to avoid accidental editing. For information to prevent access to calibration information, see [<2level>](#).**

*Note*

*A new molbox2 is delivered with all *PA* and *PM* values set to zero and 1. This does not mean that the molbox2 has not been calibrated. For the original factory calibration, privileged factory coefficients are used for calibration adjustment. This allows a new molbox2 to be delivered with virgin calibration coefficients of *PA* = 0 and *PM* = 1.*

## Required Equipment

To calibrate the molbox2 absolute reference pressure transducers (RPTs) to factory specifications, a gas operated pressure standard with these characteristics are required.

Able to apply absolute pressure in increments between:

- 20 kPa to 300 kPa (3 psia to 45 psia) for molbox2 A350K;
- 20 kPa to 600 kPa (3 psia to 87 psia) for molbox2 A700K;
- 100 kPa to 1400 kPa (14 psia to 203 psia) for molbox2-S A1.4M;
- 100 kPa to 2000 kPa (14 psia to 290 psia) for molbox2-S A2M;
- It is not necessary that the reference pressure standard used apply precisely the nominal pressure value of the calibration points as long as the exact value of the applied pressure is known. A different pressure range may be used if it is known that the molbox2 will not be used outside of the different range.
- Measurement uncertainty (accuracy) of  $\pm 0.005\%$  of reading or better, if normal molbox2 flow measurement uncertainty specifications are to be obtained. A standard with higher measurement uncertainty may be used but molbox2 flow measurement uncertainty may be proportionally degraded from published specifications.

### **Caution**

**Use only a clean dry gas source when you calibrate molbox2 RPTs. Contamination of the molbox2 with liquids can cause out of tolerance measurements and may require special factory cleaning.**

#### *Note*

*The piston gauge Model PG7601 is recommended as the reference pressure standard for the calibration of molbox2 RPTs. Contact Fluke Calibration or your local representative for additional information.*

## Set-Up and Preparation

To set-up and prepare the molbox2 for calibration:

1. Set the molbox2 on a stable surface near the calibration standard at a height as close as possible to the height of the calibration reference standard. Consider the connections that need to be made to the molbox2 rear panel pressure quick connectors and access to the display and keypad.
2. Connect the output of the calibration standard to the molbox2 rear panel CHANNEL A UP (HI) and DOWN (LO) ports. In <run> calibration mode (see [View RPT outputs](#)), with a molbox2 both absolute RPTs are connected to the CHANNEL A UP (HI) port and isolated from the DOWN (LO) port, but for a molbox2-S the absolute RPTs are independently connected to the CHANNEL A UP (HI) port and the CHANNEL A DOWN (LO) port. Use the quick connector stems (P/N 3068652, equivalent to Swagelok SS QM2 S 200) supplied with the molbox2 accessories to make the connection(s). The fitting on the quick connector stem that must be mated to is a compression type for 1/8 in. tube.

## View and Edit RPT Readings and Calibration Information

### Caution

**Editing RPT calibration information affects molbox2 pressure measurements and can cause out of tolerance flow measurements. RPT calibration information should only be edited by qualified personnel as part of the calibration process. Caution should be taken to avoid accidental editing. For information on preventing access to calibration information see [<2level>](#).**

### Purpose

To read the output of molbox2 RPTs in calibration mode. View and edit the calibration coefficients and calibration date.

### Principle

The molbox2 CAL function contains all of the functions needed to perform RPT calibrations in one menu area.

This includes:

- Viewing molbox2 RPT outputs (pressure readings) directly without the tare (see [<1tare>](#)) or head (see [<8Head>](#)) applied and configured for application of calibration pressures to run the calibration.
- Viewing PA and PM calibration coefficients and the calibration date (see [PA and PM Coefficients](#)).
- Editing PA and PM calibration coefficients and the calibration date (see [PA and PM Coefficients](#)).

### Note

See [Calibration Of Reference Pressure Transducers \(RPTS\)](#) and [PA and PM Coefficients](#) for information on molbox2 calibration coefficients (PA and PM) and their proper use.

### View RPT outputs

#### Operation

To view the molbox2 RPT outputs push  **<4cal>**, **<1pres>**, **<1upstrm or 2downstrm>**, **<1run>**. The molbox2 internal valves operate to connect both absolute RPTs to the upstream (HI) pressure port (see [Figure 15](#)) and the display shows:

upstrm	RPT	dwnstrm
97.830	kPaa	97.825

The upstream absolute RPT reading is on the left and the downstream absolute reading is on the right. The values shown are the RPT readings with the current PA and PM calibration coefficients applied but WITHOUT the tare or head applied (see <1tare> and <8Head>). Both the upstream and downstream absolute RPTs are shown together because they are nominally identical and are normally calibrated simultaneously.

Push **ESC** or **ENTER** returns to the previous screen. See [Figure 15](#).

*Note*

The RPT readings viewed under **0 SPECIAL** <4cal> do not have the tare (see <1tare>) or a head (see <8Head>) correction applied and are valid for RPT calibrations. The RPT readings viewed by pushing **5 P&T** do have tare and head values applied and therefore should not be used to take RPT calibration data (see <1tare> for information on tare values).

**Figure 15. molbox2 Internal Pneumatic Schematic - Run Upstream or Downstream Absolute RPT Calibration**

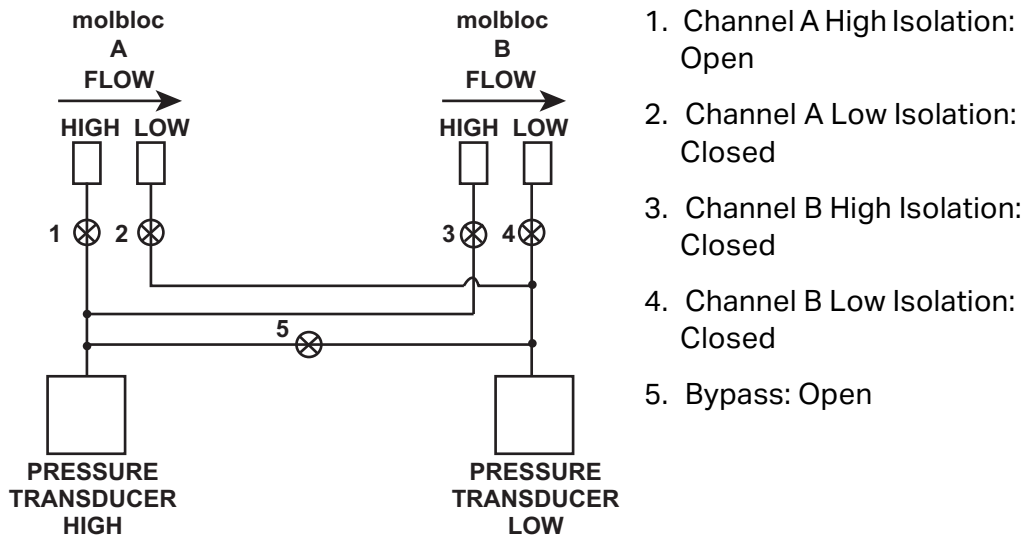

[View and Edit RPT PA, PM and Calibration Date](#)

**Purpose**

To view or edit PA and PM calibration coefficients (see [PA and PM Coefficients](#)) and the calibration date for each Reference Pressure Transducer (RPT).

*Note*

Capability to view and edit the values of the reference resistors used by the molbox2 ohmic measurement system (see [OHMIC Measurement \[Temperature\] System Verification](#)) is also provided here. This capability is normally used only by a Fluke Calibration Authorized Service Provider.

**⚠ Caution**

**Editing RPT, MFC and/or reference resistor calibration information will affect molbox2 pressure and/or temperature measurements and can cause out-of-tolerance flow measurements. Calibration information should only be edited by qualified personnel as part of the calibration process. Use caution to avoid accidental editing. For information to prevent access to calibration information, see <2level>).**



**Operation**

Push , <4cal>, <1pres> and then <1upstrm> or <2dnstrm> to specify the RPT to be viewed/edited. Finally, select <2view> to view information only or <3edit> to make changes to calibration information.

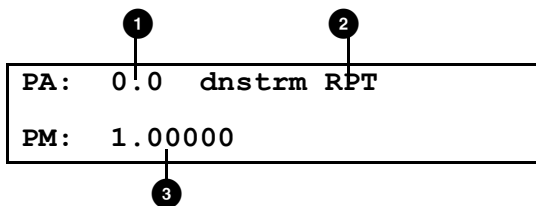
The display shows:





- ❶ - Current *adder* (always in Pascal [Pa]). This is an edit field if <3edit> was selected.
- ❷ - Indication of which RPT calibration information is being viewed/edited.
- ❸ - This is an Current *multiplier* (dimensionless). This is an edit field if <3edit> was selected.

If <3edit> was selected, edit the values of PA and PM as necessary. Push  to return to the <1run 2view 3edit> screen without making changes. Push  to continue.

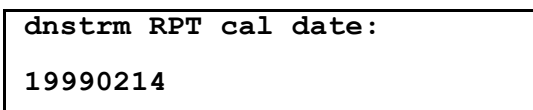
The display shows:



1. Current calibration date in YYYYMMDD format for the selected RPT. This is an edit field if <3edit> was selected. The default date is 19800101.

If <3edit> was selected, edit the calibration date as necessary with a YYYYMMDD format. Push  to return to the <1run 2view 3edit> screen without a change. Push  to continue. If <3edit> was selected and changes have been made to PA, PM or the calibration date, a confirmation screen prompts to <Activate changes>. Push  or select <1no> to return to the <1run 2view 3edit> screen without a change. Select <2yes> to activate changes and return to the <1run 2view 3edit> screen.

*Note*

*There is a specific calibration date for each RPT. To change the calibration date of one RPT does not change the other.*



*The value of PA is always in Pascal [Pa]. The value of PA must be entered in the pressure unit Pascal [Pa]. If your calibration data is in a unit other than Pascal, the calculated value of PA will be in the other unit and must be converted to Pascal before it is entered (see [Pressure](#) for pressure unit conversions). The value of PM is dimensionless*

## **RPT Calibration/Adjustment Procedure Without Using CalTool for RPTs Software**

### **⚠ Caution**

**Most users should use CalTool for RPTs software to assist in the calibration of molbox2 reference pressure transducers. CalTool for RPTs and its documentation are provided on the General Accessories Disk delivered with molbox2. Whether using CalTool or not, before you proceed to calibrate molbox2 RPTs. See [Calibration Of Reference Pressure Transducers \(RPTs\)](#) through [View and Edit RPT Readings and Calibration Information](#).**

Both molbox2 RPTs are normally calibrated simultaneously. The standard calibration procedure is:

1. Set-up and prepare the molbox2 for calibration of the RPT(s) (see [Required Equipment](#) and [Set-Up and Preparation](#)).
2. Push , **<4cal>**, **<1pres>**, **<1upstrm>**, **<2view>** to read and record the current values of PA and PM for the upstream RPT. Then repeat the process selecting **<2dnstrm>** to read and record the downstream RPT PA and PM (see [View and Edit RPT PA, PM and Calibration Date](#)).
3. Push , **<4cal>**, **<1pres>**, **<1upstrm>** or **<2dnstrm>**, **<1run>** to show the real-time pressure readings of the RPT(s) to be calibrated (see [View RPT outputs](#)).
4. Apply the calibration pressures to the RPT(s) recording the pressure applied by the standard and the molbox2 RPT readings at each calibration point.
5. See the beginning of [Required Equipment](#) for the standard calibration range for the RPTs. Dwell at least 60 seconds after setting the reference pressure at each point to allow full stabilization. The data recorded is the *as receive* data for this calibration.
6. Enter the calibration pressure and RPT readings for each point into a spreadsheet. Calculate the *non corrected* RPT readings by backing out the *as received* PA and PM recorded in step 2 above, following:

$$\text{non-corrected reading} = (\text{corrected reading} - \text{PA})/\text{PM} + \text{Poffset}$$

7. Do a best fit linear regression to find the offset and slope that best fit the non-corrected RPT readings to the calibration standard pressures. Most commercial spreadsheet products have a standard function to perform a linear regression. The offset, in Pascal [Pa], is the new value of *PA*, the slope is the new value of *PM*.
8. Push , **<4cal>**, **<1pres>**, **<1upstrm>** or **<2dnstrm>**, **<2edit>** to write the new values of *PA* (always in Pascal) and *PM* and the new calibration date (YYYYMMDD) for the RPT that is being calibrated.
9. Calculate *as left data* for the calibration:

$$\text{as left reading} = (\text{non-corrected reading} \bullet \text{new PM}) + \text{new PA}$$

10. To verify the as left data, rerun the calibration with the new *PA*(s) and *PM*(s) applied and check that the disagreements between the calibration standard and the RPT readings are in tolerance.

### **Caution**

**The value of *PA* must be entered in the pressure unit Pascal [Pa]. If the calibration data is in a unit other than Pascal, the calculated value of *PA* will be in the other unit and must be converted to Pascal before it is entered (see [Pressure](#) for pressure unit conversions).**

**If unfamiliar or uncomfortable with the mathematics used for *PA* and *PM* manipulation, Fluke Calibration recommends you verify the as left readings as suggested in Step 10 above to provide practical confirmation of the integrity of the calculations. Note also that the CalTool for RPTs software delivered with the molbox2 does the necessary calculations automatically.**

## **MFC Control Function Adjustment**

### **Purpose**

To verify and adjust the voltage and/or current measurements made by molbox2 optional MFC control function.

### *Note*

*Capability to view and edit the values of the voltage references resistors used by the molbox2 optional MFC control function is also provided here. This capability is normally used only by a Fluke Calibration authorized service provider.*

### **Principle**

molbox2 may be delivered with an optional MFC control function. The MFC control function allows voltage of current set points to be applied to an MFC and voltage or current values to be read back from an MFC or MFM.

The MFC control function is self-calibrating by on-board 5 V and 10 V references. Voltage is converted to current using a precision 250 Ω resistor.

The MFC control function signals are:

- sense (V)
- measure (V or mA)
- valve (V)
- negative power supply (V)
- positive power supply (V)
- set (V or mA)

See Section [MFC Control Option Connection](#) for complete MFC control specifications.

You can adjust any of the MFC control signals with adders and multipliers in the same manner as the pressure adders and multipliers used to adjust the molbox2 RPTs (see [PA and PM Coefficients](#)). The normal procedure, however, is to use the molbox2 Analog Calibration software and cable provided with the accessories of a molbox2 delivered with the optional MFC control function.

See [MFC Control Function-MFC Connector](#) for MFC control function pin out details.

## Operation

### Note

*This section describes the operation of the features available to adjust the optional molbox2 MFC control function signals. The normal procedure to calibrate or adjust these signals is to use the molbox2 Analog Calibration software provide in the molbox2 accessories. The features described here are made available for advanced users who want to perform customized adjustments.*

To access the MFC control function signal adders and multipliers pressure  **<4cal>**, **<3MFC>**, **<1cal>**. The display shows:

```
Channel1:1sense 2meas
3valve 4neg 5pos ↓
6set
```

Each selection shows the signal adder and multiplier. For certain signals, you must select **<1voltage>** or **<2current>**. In this case, there are separate and distinct adders and multipliers for voltage and current readings.

- <1sense>**: Set point sense. Voltage only.
- <2meas>**: Output from the MFC or MFM sensor. Voltage or current.
- <3valve>**: Valve test line to measure the internal voltage of an MFC valve. Voltage only.
- <4neg>**: -15 V dc power supply. Voltage only.
- <5pos>**: +15 V dc power supply. Voltage only.
- <6set>**: MFC set point command. Voltage or current.

## **OHMIC Measurement [Temperature] System Verification**

### **Purpose**

To verify the measurements made by the molbox2 ohmic measurement system for temperature.

### **Principle**

molbox2 includes an ohmic measurement system used to measure the resistance of the two Platinum Resistance Thermometers (PRTs) mounted in molblocs. The temperature of the PRTs is calculated from the resistance. The molbloc PRTs have nominal resistance at 0 °C of 100 Ω and a slope of 0.3896 following DIN Norm 43760. The calibrated Rzero corresponding to the resistance at 0 °C for each PRT is stored on the molbloc EEPROM and read by the molbox2.

The ohmic measurement system self-calibrates using on-board 100 Ω and 110 Ω reference resistors. On molbox2 power up, an automated routine adjusts the ohmic measurement system relative to on board, reference resistor readings. The on-board reference resistors used to calibrate the molbox2 measurement system have accuracy of ±0.01 % and stability of ±0.0025 % for one year, ±0.005 % for 3 years.

The self-calibration feature and the very high accuracy and stability of the reference resistors relative to the accuracy tolerance on the molbox2 temperature measurements make the need to calibrate the ohmic measurement system independently unlikely. It is good practice, however, to verify the ohmic measurement system. This is most easily accomplished globally by connecting a known resistance value to the measurement circuit where the molbloc PRTs are normally connected and verifying that the molbox2 reads the correct corresponding temperature when that resistance is connected. Reference resistors mounted in a molbloc simulator for easy connection to molbox2 with the normal molbloc connection cable can be purchased from your Fluke Calibration sales representative [molbloc simulators: 100 Ω (0 °C nominal) P/N 3069694, 107 Ω (18 °C nominal) P/N 3069682, 110 Ω (25°C nominal) P/N 3069701]. These are nominal resistors whose values are reported and can be measured independently if necessary. The measured resistance of the reference resistors and a value for resistance at 0 °C of 100 Ω are programmed on the simulator EEPROM. With these values, if the molbox2 ohmic measurement system and associated connections are working properly, when the simulator is connected the molbloc temperature indicated by molbox2 should equal the reference temperature that corresponds to the molbloc simulator reference resistors Rzero values following:

$$\text{Reference temperature [°C]} = (\text{Reference resistor value [Ω]} - 100) / 0.3896$$

The **Reference temperature [°C]** calculated from the actual reference resistor value is written on the molbloc simulator. The temperature value read by the molbox2 when the molbloc simulator is connected. Push  to see the value (see [\[P&T\] \(Pressure and Temperature\)](#)). The disagreement between the reference temperature and the molbloc indication should not exceed 0.05 °C.

*Note*

*Because the ohmic measurement system is set up to measure two PRTs, there are two reference resistors in the molbloc simulator. Their resistance is not identical so there are actually two reference temperatures printed on the molbloc simulator and an average temperature which correspond to the three temperatures on the molbox2  temperature display (see [\[P&T\] \(Pressure and Temperature\)](#)).*

## Operation

To verify the molbox2 ohmic measurement system:

1. Connect a molbloc simulator to the molbox2 Channel A and initialize it as if connecting a molbloc (see [<1 molbloc>](#)).
2. Push  twice to display the molbox2 temperature measurement.
3. Compare the three molbox2 temperature measurements (upstream, downstream, and average) to the calculated reference temperature values written on the molbloc simulator.
4. Repeat steps 1 through 3 for the other simulators and/or for Channel B.
5. If all disagreements between molbox2 indications and corresponding calculated reference temperatures are less than 0.05 °C, the ohmic measurement system verification passed.

If any disagreement between a molbox2 indication and the corresponding calculated reference temperature is greater than 0.05 °C, the ohmic measurement system verification failed.

Possible reasons for failure include:

- faulty molbox2 internal reference resistor(s)
- faulty molbox2 internal relays
- faulty connections between molbox2 and the molbloc simulator
- faulty molbloc simulator

Check the molbox2 to molbloc simulator connections and repeat the verification.



### **Caution**

**Push  and select <4cal>, <2temp> to provide access to view and edit the value of the molbox2 channel dependent temperature adders and multipliers. To alter these values causes out of tolerance flow readings. In normal circumstances, these values are only altered by the factory when a reference resistor is replaced and great care and consideration should be used if they are to be altered by the user.**

## OHMIC Measurement System Calibration/Adjustment Procedure

The molbox2 channels are calibrated individually. The standard calibration procedure requires at least two simulators.

The procedure follows:

1. With Channel A selected, push , **<4cal>**, **<2temp>** to read and record the current values of *TA* and *TM* for Channel A, then exit to the main run screen to select Channel B and repeat the process to read and record the current values of *TA* and *TM* for Channel B.
2. With Channel A selected, push  twice to show the real time temperature readings.
3. Connect a molbloc simulator to the molbox2 Channel A and initialize it as if connecting a molbloc (see [<1molbloc>](#)).
4. Enter the average molbloc simulator calibrated temperature and the molbox2 top row centered calibration temperature reading (the averaged temperature) for each temperature point into a spreadsheet. Repeat steps 3 and 4 for each simulator. Calculate the *non corrected* temperature readings by backing out the as received *TA* and *TM* recorded in Step 1 above, following:

$$\text{non-corrected reading} = (\text{corrected reading} - TA)/TM$$

5. Perform a best fit linear regression to find the offset and slope that best fit the non-corrected temperature readings to the calibrated molbloc simulator temperatures. Most commercial spreadsheet products have a standard function to perform a linear regression. The offset, in the current temperature unit, is the new value of *TA*, the slope is the new value of *TM*.
6. Push , **<4cal>**, **<2temp>** to write the new values of *TA* (in the current unit of measure) and *TM* and the new calibration date (YYYYMMDD) for the channel that is being **calibrated**.
7. Calculate *as left data* for the calibration:

$$\text{as left reading} = (\text{non-corrected reading} \bullet \text{new } TM) + \text{new } TA$$

8. To verify the **as left** data, rerun the calibration with the new *TA* and *TM* applied and checking that the disagreements between the molbloc simulators and the molbox2 temperature readings are in tolerance.
9. Repeat steps 2 through 8 for Channel B.

**⚠ Caution**

Enter the value of *TA* in the current unit of measure, either °C or °F, shown by the molbox2.

If unfamiliar or uncomfortable with the mathematics used for *TA* and *TM* manipulation, Fluke Calibration recommends that you verify the as left readings as suggested in Step 8 above to provide practical confirmation of the integrity of the calculations.

If an out-of-tolerance condition persists, the molbox2 and/or the molbloc simulator(s) may need service.

## **molbloc Flow Adjustment**

### **Purpose**

To allow linear adjustments to existing gas specific molbloc calibrations.

**⚠ Caution**

This correction does not take into consideration changes in the molbloc Reynolds number. It is a pure adder/multiplier applied to the molbloc flow. For a molbloc-L a variety of upstream and downstream pressure and temperature combinations may yield the same Reynolds number. It is important to calibrate the molbloc in the conditions of normal use to avoid inducing additional error associated with changes in the Reynolds number.

For true factory style gas calibrations or addition of gas calibrations not previously on the molbloc, the use of the CalTool for molbloc Extension to COMPASS for Flow is highly preferable if access to a sufficiently accurate flow reference is available.

### **Principle**

The adjustments are stored on the molbloc EEPROM along with the factory calibration coefficients and does not apply to any other molbloc or gas calibration. The correction is applied whenever the specific gas calibration is selected on the adjusted molbloc when connected to a molbox2. This feature does not support adding new calibrations to the molbloc.

The coefficients used to adjust the gas calibration are designated *FA* (a flow *adder* or offset) and *FM* (a flow *multiplier* or span set). Fluke Calibration does not recommend the use of *FA* as this is an offset value (% of FS) that could negatively impact the molbloc, which is a % of reading device. Whenever possible, Fluke Calibration recommends to make all corrections with the *FM*. The coefficients affect the flow reading following:

$$\text{Corrected reading} = (\text{uncorrected reading} \bullet FM) + FA$$

*FA* is expressed in flow (always the current unit of measure (for example, sccm or slm).

*FM* is dimensionless.

The *FA* and *FM* values currently in use for the calibrated gas can be viewed in the CALIBRATION function. If adjustments are necessary when you calibrate a molbloc, to make the adjustments, adjust the *FA* and *FM* values.

**⚠ Caution**



**To edit the *FA* and *FM* values will change the molbloc gas calibration. They should only be edited by qualified personnel as part of a flow calibration process. Use caution to avoid accidental edits. For information to prevent access to calibration information, see <2level>.**

*Note*

*A new molbloc is delivered with all *FA* and *FM* values set to zero and 1. This does not mean that the molbloc has not been calibrated. For the original factory calibration, privileged factory coefficients are used for calibration adjustment. This allows a new molbloc to be delivered with original calibration coefficients of *FA* = 0 and *FM* = 1.*

## **molbloc Adjustment Procedure Without Using CalTool for molbloc Software**

The standard calibration procedure is:

1. To set-up and prepare the molbloc for calibration of the flow, connect the molbloc to a flow reference with the gas to be tested.
2. Push , **<4cal>**, **<4gas>**, and select the gas calibration on the molbloc to be adjusted to read and record the current values of *FA* and *FM*.
3. Push  several times to return to the main run display to see the real time flow readings of the molbloc to be calibrated.
4. Apply the calibration flow to the molbloc recording the flow applied by the standard and the molbloc readings at each calibration point.
5. Dwell at least 60 seconds after setting the reference flow at each point to allow full stabilization. The data recorded is the *as received* data for this calibration.
6. Enter the reference flow and molbloc flow readings for each point into a spreadsheet. Calculate the *non corrected* readings by backing out the *as received* *FA* and *FM* recorded in Step 2 above, following:

$$\text{non-corrected reading} = (\text{corrected reading} - \text{FA})/\text{FM}$$

7. Do a best fit linear regression to find the offset and slope that best fit the non-corrected flow readings to the calibration reference flows. Most commercial spreadsheet products have a standard function to perform a linear regression. The offset, in the current unit of measure, is the new value of *FA*, the slope is the new value of *FM*.
8. Push , **<4cal>**, **<4gas>**, and select the gas calibration on the molbloc to be adjusted to write the new values of *FA* (always in the current unit of measure) and *FM* and the new calibration date (YYYYMMDD) for the gas that is being calibrated.

9. Calculate *as left data* for the calibration:

$$\text{as left reading} = (\text{non-corrected reading} \bullet \text{new FM}) + \text{new FA}$$

10. Verify the *as left data* by rerunning the calibration with the new *FA* and *FM* applied and check that the disagreements between the calibration standard and the RPT readings are in tolerance.

### **⚠ Caution**

**If possible, only use a value of *FM* to correct for slope changes of the molbloc in the calibrated gas and leave *FA* set to 0 at all times, as *FA* is an offset value that does not ideally fit the % of reading design of a molbloc calibration.**

**The value of *FA* must be entered in the flow unit of measure used to gather the data. If the calibration data is in a different unit, the calculated value of *FA* will be in the other unit and must be converted to the unit the data was gathered in before it is entered.**

**If unfamiliar or uncomfortable with the mathematics used for *FA* and *FM* manipulation, Fluke Calibration recommends that you verify the *as left* readings as suggested in Step 10 above to provide practical confirmation of the integrity of the calculations. Note also that the CalTool for molbloc Extension to COMPASS for Flow software performs the necessary calculations automatically.**

## **Reloading Embedded Software Into molbox2 Flash Memory**

molbox2 uses FLASH memory. This allows the embedded software that controls molbox2 operations and functions to be loaded into molbox2 over its COM1 port from a personal computer with a simple FLASH loading utility.

To replace corrupted software or upgrade to a new version, your Fluke Calibration authorized service provider can provide a FLASH memory loading utility along with a file of the molbox2 embedded software. These are available for download from [www.fluke.com](http://www.fluke.com). If the embedded software that you use is suspected of a problem, record all symptoms and contact your Fluke Calibration authorized service provider.

## **Reload molbloc EEPROM File**

molbloc EEPROMs are programmed with:

- A molbloc identifying header with range identifier, S/N and calibration date.
- molbloc specific flow calibration coefficients for N2, and other gases if entered.
- The resistance at 0 °C of the molbloc platinum resistance thermometers (PRTs).

If the molbloc EEPROM information becomes corrupted, molbox2 will be unable to read the molbloc EEPROM and will show **<NO BLOC>** when you attempt to initialize the molbloc.

Fluke Calibration maintains files of the *as shipped* EEPROM contents of every molbloc delivered or recalibrated by Fluke Calibration. A molbloc EEPROM loading tool may be downloaded from [www.fluke.com](http://www.fluke.com). If you believe you have a molbloc with a corrupted EEPROM, contact your Fluke Calibration authorized service provider for additional information on the molbloc EEPROM loading tool and obtaining molbloc data files.

## OVERHAUL

### Caution

**If calibration of the Reference Pressure Transducers (RPTs) is included as part of the overhaul procedure, do the calibration procedure last as other overhaul procedures may affect RPT calibration.**

Any or all of these items may be included as part of a system maintenance overhaul:

- Clean front panel.
- Check that rear mounted cooling fan operates when molbox2 is powered.

### Note

*To open the molbox2 case, fold back the screw covers on the top and bottom of the case. Then remove the eight case screws. Lift OFF the cover and bottom and place the molbox2 on its side for easy access to internal components.*

- Disassemble valving assembly and clean valve components.
- Check that internal screws, bolts and nuts are tight.
- Do the molbox2 leak check (see [<3Leak Check>](#)) and connect a molbloc to verify operation (see [<1molbloc>](#)).
- Calibrate RPTs, if necessary (see [Calibration Of Reference Pressure Transducers \(RPTS\)](#)).
- Calibrate the MFC control function if the option is present (see [MFC Control Function Adjustment](#)).
- Verify the ohmic measurement circuit if necessary (see [OHMIC Measurement \[Temperature\] System Verification](#)).

## Troubleshooting

Before you assume that unexpected behavior is caused by a system defect or breakdown, use this manual and other training facilities to become thoroughly familiar with molbox2 operation. This troubleshooting guide aids in identifying the cause of unexpected molbox2 behavior and helps to determine whether the behavior is due to normal operation or an internal or external problem.

If the Product seems faulty or the problem cannot otherwise be solved, contact an authorized service center for assistance, see [Contact Fluke](#). Make sure to have the Product model number, serial number, and regional voltage available to tell the service technician.

Identify the symptom or unexpected behavior that you observed from the Symptom list in [Table 30](#). A Probable Cause is provided and a Solution is proposed including references to manual sections that provide information that may be of assistance.



**Table 30. Troubleshooting List**

<b>Symptom</b>	<b>Probable Cause</b>	<b>Solution</b>
Will NOT power up.	Blown fuse.	Replace fuse in power entry module. Check the mains fuses. If a fuse is blown, replace the fuse once. DO NOT replace the fuse with ones of a higher current rating. Always replace the fuses with one of the same rating, voltage, and type. Fuse ratings can be found in the safety information document that shipped with the product and at <a href="http://www.fluke.com">www.fluke.com</a> . If the fuse blows a second time, it is likely caused by failure of a component part.
Front panel keys seem to be disabled.  active only.	<i>Remote</i> command has been sent from a host computer locking out the front panel keypad.	Operation is normal. Send <i>local</i> command from host computer or cycle molbox2 power. <a href="#">IEEE-488 (GPIB)</a>
Display is dim.	Screen saver option has activated.	Operation is normal. Push any key to resume full screen power, adjust Screen Saver activation time if necessary. <a href="#">&lt;1ScrSVR&gt;</a>
Keypad pushes make no sounds.	molbox2 does not support keypad sounds.	Operation is normal.
Cannot access certain functions. Display shows: <b>&lt;ACCESS RESTRICTED&gt;</b> .	User level setting restricts access to that function.	Operation is normal. Change user level or consult system manager. <a href="#">&lt;2level&gt;</a>
Cannot establish communication over remote interface.	Computer and/or molbox2 interface incorrectly configured. Incorrect or bad interface cable.	Check and correct interface configurations and cables if necessary. <a href="#">&lt;6REMOTE&gt;</a> , <a href="#">Remote Operation</a> .

**Table 30. Troubleshooting List (cont.)**

<b>Symptom</b>	<b>Probable Cause</b>	<b>Solution</b>
molbox2 unable to read molbloc.	Cable not connected, molbloc data corrupted.	Check cable connections, try another molbloc, reload molbloc EEPROM. <a href="#">&lt;1molbloc&gt;</a> , <a href="#">Reloading Embedded Software Into molbox2 Flash Memory</a>
Displays <b>&lt;FATAL ERROR&gt;</b> or <b>&lt;FATAL FAULT&gt;</b> .	Encountered unresolved internal software conflict.	Cycle power to clear. Record conditions that lead up to event that include the numbers shown when  is pushed and report to Fluke Calibration authorized service provider.
Displays <b>&lt;PRTErr&gt;</b> or <b>&lt;ACALERR&gt;</b> .	molbox2 has identified an unusually large disagreement between the temperature readings of the two molbloc PRTs which may be due to faulty molbloc PRTs or the molbox2 ohmic measurement system.	Connect a different molbloc. If the error is still present, open molbox and check ribbon cable connections. If the error is no longer present, the PRT system of the original molbloc is probably damaged and requires service. If the PRT error is present with different molblobs, the molbloc/molbox cable or molbox2 ohmic measurement system is probably defective and requires services. <a href="#">[P&amp;T] (Pressure and Temperature)</a> , <a href="#">OHMIC Measurement [Temperature] System Verification</a>
Display <b>&lt;TOUT&gt;</b> or <b>&lt;TIME-OUT&gt;</b> .	molbox2 is having an internal communications problem with one or both of its RPTs.	Turn power off and back on and/ or execute Reset – Sets being careful to reenter necessary settings afterward. If problem persists, molbox2 needs service. <a href="#">&lt;1sets&gt;</a>

**Table 30. Troubleshooting List (cont.)**

Symptom	Probable Cause	Solution
Displays <b>&lt;NO BLOC&gt;</b> .	No molbloc is connected to molbox2 or molbox2 is unable to read the molbloc that is connected.	Verify proper electrical connection between the molbox2 and a valid molbloc. If <b>&lt;NO BLOC&gt;</b> is observed with one molbloc and not others, molbloc is damaged and/or EEPROM is corrupted. <a href="#">&lt;1molbloc&gt;</a> , <a href="#">Reloading Embedded Software Into molbox2 Flash Memory</a>
Displays <b>&lt;*****&gt;</b> where a numerical value should go.	Number to be shown is too large for allocated space. Usually due to an erroneous setting or measurement causing an out of limit value to be calculated.	Check settings that may be the cause of an out of limit measurement and adjust if necessary. <a href="#">[RES]</a> , <a href="#">[K]</a> , <a href="#">&lt;3ADJ&gt;</a>
Bottom line of display has changed and you want to change it back.	The DISPLAY function has been used to change the display.	Use  to set bottom line to necessary display. <a href="#">[DISPLAY]</a>
Bottom line of display is blank.	DISPLAY mode is <i>clean</i> .	Operation is normal. Use  to change bottom line display if necessary. <a href="#">[DISPLAY]</a>
Display shows pressure values and flashes, beeper is sounding two second beeps.	Pressure applied to one or both of the absolute RPTs is near overpressure.	Reduce pressure applied to upstream (HI) and downstream (LO) molbloc pressure connection ports and cycle power on molbox2. <a href="#">Upper Limit Alarm and Sequence, Reference Pressure Transducer (RPT) Overpressure</a>
Display shows <b>&lt;OVERP!&gt;</b> .	One or both of the molbox RPTs has been overpressured.	Remove the source of overpressure and push  to clear. Check molbox RPTs for damage. <a href="#">Upper Limit Alarm and Sequence, Reference Pressure Transducer (RPT) Overpressure</a>
Display shows <b>&lt;BPR HI&gt;</b> where the flow value should go.	molbox2 is in molbloc-S mode and the ratio of downstream pressure to upstream pressure (B\PR) is too high to make a valid flow measurement.	Operation is normal. Increase flow to increase upstream pressure and/or decrease downstream pressure. <a href="#">molbloc-S BPR Limits, &lt;9BPR&gt;</a>

**Table 30. Troubleshooting List (cont.)**

<b>Symptom</b>	<b>Probable Cause</b>	<b>Solution</b>
Flow indication is flashing in molbloc-L mode	Flow is 5 % or more beyond the maximum flow for a named cal molbloc gas calibration.	Operation is normal. Indicates that flow is beyond the molbloc-L calibrated range <i>Premium molbloc-L Calibrations, molbloc-L Pressure Dependent Calibration Types, Main Run Screen</i>
Flow indication flashes in molbloc-L mode	Pressure is 10 kPa above the maximum pressure or 10 kPa below the minimum pressure for a named cal molbloc gas calibration.	Operation is normal. Indicates that flow is beyond the molbloc-L calibrated range <i>Premium molbloc-L Calibrations, molbloc-L Pressure Dependent Calibration Types, Main Run Screen</i>
Flow indication flashes in molbloc-L mode	Reynolds number is >1300	Operation is normal. Indicates that flow is beyond the molbloc-L range <i>Premium molbloc-L Calibrations, molbloc-L Pressure Dependent Calibration Types, Main Run Screen</i>
Flow indication flashes in molbloc-S mode	Flow is 5 % or more beyond the maximum flow for a named cal molbloc gas calibration.	Operation is normal. Indicates that flow is beyond the molbloc-S calibrated range <i>Premium molbloc-L Calibrations, molbloc-L Pressure Dependent Calibration Types, Main Run Screen</i>
Flow indication flashes in molbloc-S mode	Pressure is 10 kPa above the maximum pressure or 10 kPa below the minimum pressure for a named cal molbloc gas calibration.	Operation is normal. Indicates that flow is beyond the molbloc-S calibrated range <i>Premium molbloc-L Calibrations, molbloc-L Pressure Dependent Calibration Types, Main Run Screen</i>

**Table 30. Troubleshooting List (cont.)**

<b>Symptom</b>	<b>Probable Cause</b>	<b>Solution</b>
Flow indication flashes in molbloc-S mode	Back pressure ratio is too high to establish critical flow through the molbloc-S.	Operation is normal. Increase molbloc-S upstream pressure or reduce downstream pressure to reduce BPR below the BPR limit at the current Reynolds numbers. <a href="#">molbloc-S BPR Limits</a> , <a href="#">Premium molbloc-L Calibrations</a> .
Flow indicated by molbox2 never becomes stable.	The flow through the molbloc is not stable.	The molbox2 passively measures the flow through the molbloc. It does not control flow. Correct conditions that cause unstable flow.
A <i>Ready</i> (<*>) indication is never achieved in molbloc-L mode.	Flow stability criterion is never being met and or Reynolds number limit of 1200 (1550 for 3E4-L) is being exceeded.	Adjust stability criterion or stabilize flow. Reduce the flow rate and/or pressure to reduce the Reynolds number of the flow. <a href="#">&lt;2stab&gt;</a>
<i>Ready</i> (<*>) indication and measured flow value are flashing in molbloc-L mode.	The flow is within the stability limit but the Reynolds number of the flow exceeds the maximum acceptable limit of 1200 (1550 for 3E4-L).	Operation is normal.
Pressure indicated by molbox2 never becomes stable.	There is a leak in the molbox2 and/or in the system to which it and the molbloc are connected.	Find and correct leak. Consider using molbox2 LEAK CHECK functions. <a href="#">&lt;3Leak Check&gt;</a>
Flow indication appears to be grossly incorrect.	Your assumption of flow in the system is grossly incorrect.	Check and adjust flow in the system.
Flow indication appears to be grossly incorrect.	The molbloc connected to molbox2 has been swapped without reinitialization so molbox2 is still using characteristics from a previous molbloc.	Reinitialize molbloc with  <a href="#">&lt;1molbloc&gt;</a> . <a href="#">&lt;1molbloc&gt;</a>

**Table 30. Troubleshooting List (cont.)**

<b>Symptom</b>	<b>Probable Cause</b>	<b>Solution</b>
In molbloc-S mode, there is no flow through the molbloc but molbox2 is indicating a large flow value.	molbox2 is in BPR OFF mode and flow is being calculated from upstream absolute pressure without knowledge of downstream pressure.	Behavior is normal. Consider BPR when you evaluate flow measurements when using molbloc-S. Also consider changing BPR mode to Auto or ON. <i>molbloc-S BPR Limits, &lt;9BPR&gt;, &lt;5BPR&gt; (molbloc-S Operation Only)</i>
Flow indication appears to be incorrect.	molbox/molbloc and/or the device you are comparing it to are in tolerance but you have not properly evaluated the tolerance limits.	Determine flow measurement tolerance of molbloc/molbox and device you are comparing with. Evaluate <i>correctness</i> relative to the combined tolerance of the two. <i>Flow Measurement Specifications</i>
Flow indication appears to be incorrect.	Reference pressure transducer(s) (RPTs) are inoperable or out of calibration.	Use  to view pressure indications. Recalibrate RPTs if necessary. <i>[P&amp;T] (Pressure and Temperature), Calibration Of Reference Pressure Transducers (RPTS)</i>
Flow indication appears to be incorrect.	The gas selected is not the gas flowing through the molbloc.	Select the correct gas. <i>[GAS]</i>
Flow indication appears to be incorrect while using molbloc-S to measure air flow	Incorrect humidity ratio is being used.	Reselect Air as the test gas and make sure the humidity ratio W is entered properly. W should be zero for dry air and should be calculated from ambient conditions when measuring ambient air. <i>molbloc-S Operation.</i>

**Table 30. Troubleshooting List (cont.)**

<b>Symptom</b>	<b>Probable Cause</b>	<b>Solution</b>
Flow indication appears to be incorrect.	The gas selected is the gas that flows through the molbloc but the molbloc has not been calibrated for that gas.	Verify that the molbloc has calibration coefficients for the flowing gas, have the molbloc calibrated for the flowing gas if necessary or accept higher measurement uncertainty in the flow measurements. <1molbloc>, <a href="#">Flow Measurement Specifications</a>
Flow indication appears to be incorrect.	Gas flowing through molbloc is not pure.	Check purity rating of gas used; purge molbox/molbloc if flowing gas was just changed. If gas is a known mix, use the flow <i>adder</i> and <i>multiplier</i> to correct for the mix. <2Purge>, <3ADJ>
Flow indication appears to be incorrect.	The molbloc is not being used at the correct pressure for its pressure dependent calibration type.	Check molbloc Calibration Report for pressure dependent calibration type and check operating pressure. <a href="#">Flow Measurement Specifications</a>
Flow indication appears to be incorrect.	molbox2 pressure and/or Reynolds numbers are outside of limits.	Observe pressure and Reynolds numbers and adjust pressure/ flow to be inside of limits. <a href="#">Flow Measurement Specifications, [P&amp;T] (Pressure and Temperature)</a>
Flow indication appears to be incorrect.	Flow through molbloc is in wrong direction.	Check that flow through molbloc is in direction of arrow on molbloc. Switch if necessary.
Flow indication appears to be incorrect.	Leak in pressure lines from molbloc to molbox2.	Check lines for leaks and correct if necessary. <3Leak Check>
Flow indication appears to be incorrect.	A flow adder or multiplier has been incorrectly or inadvertently applied.	Check and correct if necessary. <3ADJ>
Flow indication appears to be incorrect.	molbloc calibration has changed due to contamination.	Check molbloc for contamination. Contact your Fluke Calibration authorized service provider if liquid or particulate contamination is detected.



**Table 30. Troubleshooting List (cont.)**

<b>Symptom</b>	<b>Probable Cause</b>	<b>Solution</b>
Flow indication appears to be incorrect by a constant offset amount.	molbox2 needs to be correctly zeroed ( <i>tared</i> ) at the current operating pressure.	<i>Tare</i> molbox2. Be sure to <i>tare</i> upstream if the upstream pressure is constant and downstream if the downstream pressure is constant. <a href="#">&lt;1tare&gt;</a>
Flow indication appears to be incorrect and molbloc is upstream and reading high.	Leak downstream of molbloc.	Check for and correct leak if present. Consider using molbloc2 SYSTEM LEAK CHECK function. <a href="#">&lt;3Leak Check&gt;</a>
Flow indication appears to be incorrect and flow rate is less than 50 sccm.	Flow in system is not in steady state; too much volume between molbloc and test; unstable pressure on molbloc.	Be sure flow is stable before reading, reduce dead volumes, install precision regulator, consider using low flow molstic.
Flow indication appears to be incorrect and flow unit is a volumetrically based mass flow unit (sccm, scfh, for example).	Reference temperature or compressibility consideration in volumetrically based units is inconsistent.	Set units correctly for consistency between values being compared. Be sure to select a unit starting in <i>u</i> for volumetrically based mass flow units if reference temperature is not 0 °C. <a href="#">[UNIT], Volumetrically Based Mass Flow Units at Various Reference Temperatures (UXXX)</a>
Unable to make molbloc-S flow measurements over full expected flow range	MFC or flow control valve is connected downstream of molbloc-S	Valve or regulator used to control flow through molbloc-S must always be upstream of the molbloc-S. When operating an MFC with molbloc-S, the MFC must always be upstream.
Unable to make molbloc-S flow measurements over full expected flow range	molbloc-S back pressure too high	The downstream pressure on molbloc-S must always be significantly lower than the upstream pressure to maintain critical flow. When upstream pressure is reduced, the back pressure ratio may become too high to make valid flow measurements. <a href="#">molbloc-S BPR Limits</a>

**Table 30. Troubleshooting List (cont.)**

<b>Symptom</b>	<b>Probable Cause</b>	<b>Solution</b>
Unable to make molbloc-S flow measurements over full expected flow ranges.	Flow units use reference temperature other than 0° C.	The molbloc-S flow range tables display flow ranges expressed in slm @ 0° C. If you use volumetrically based flow units with another reference temperature, the minimum usable flow value may be increased by up to 9% for a given molbloc-S downstream pressure. <i>Standard molbloc-S calibrations are in Table 5., Volumetrically Based Mass Flow Units at Various Reference Temperatures (UXXX), Table 7 and Table 44.</i>
Unable to reach molbloc-S maximum flow	Pressure regulator supplying molbloc-S set too low.	If controlling flow with a control valve downstream of a fixed pressure regulator, you must have sufficient pressure supply pressure to reach the maximum desired molbloc-S flow. Be sure not to exceed molbox2 maximum operating pressure. <i>Flow Measurement Specifications, Gas Supply and Flowpath Connections</i>
Flow indication appears to be incorrect and flow unit is a volume (actual) flow unit (ccm, cfh, for example).	Volume flow pressure and/or temperature is/are incorrect.	Set more accurate values for volume flow pressure and/or temperature. <i>Mass Flow vs. Volume Flow, Volume Flow Units (vlm)</i>
Flow indication appears to be incorrect and there is a K following the flow unit on the display.	A K factor is being applied incorrectly or inadvertently.	Turn off or correct K factor. <i>[K]</i>
Flow indication appears to be incorrect and you are using AVERAGING function.	Averaging period is wrong and does not correspond to reading period of the device you are comparing with.	Adjust averaging period and/or be sure to synchronize averaging period of the molbox2 and the device you are comparing to. <i>&lt;2Avg&gt; (Average)</i>



**Table 30. Troubleshooting List (cont.)**

<b>Symptom</b>	<b>Probable Cause</b>	<b>Solution</b>
Flow indication is negative.	Flow in your system is reverse from what you expect; molbloc upstream and downstream pressure lines are switched.	Check system and correct flow; check pressure lines and switch if necessary.
Pressure transducer (RPT) indications are out of range.	Incorrect RPT calibration coefficients; RPT(s) has (have) been overpressured.	Correct calibration coefficients; have transducers replaced if damaged. <a href="#">Calibration Of Reference Pressure Transducers (RPTS)</a>
molbloc-S Tare does not execute as expected	Expectation of tare function operation is incorrect for molbloc-S.	Normal molbox2 operation. The molbloc-S tare function has a different purpose and method of operation from molbloc-L tare and does not require saving a fixed tare value.
Cannot tare molbox due to excessive tare value.	One or several RPTs are defective; RPT calibration is bad; there is a leak inside molbox2 causing a differential pressure.	Check performance of RPTs; check calibration of RPTs; leak check molbox2. <a href="#">Calibration Of Reference Pressure Transducers (RPTS)</a>
Leak check does not indicate pass/fail in molbloc-S operation.	Improper expectation for molbloc-S leak check.	Normal molbox2 operation. molbloc-S system leak check function in molbox2 does not have pass/fail criteria assigned as molbloc-L leak check does. <a href="#">&lt;3Leak Check&gt;</a>
Measured pressure display has too much/not enough resolution.	Resolution setting needs to be changed.	Use  to change resolution setting. <a href="#">[RES]</a>
Flow rate is changing but display of flow is not and the bottom right hand corner of the display is a numerical countdown followed by <b>&lt;avg&gt;</b> .	AVERAGE DISPLAY function is ON and pressure display is updating only with the average value at the end of each averaging cycle.	Go to a DISPLAY function other than AVERAGE or push  to get the instantaneous value AVERAGE DISPLAY. <a href="#">&lt;2Avg&gt; (Average)</a>
Current flow through the molbloc is zero but reading is not zero in molbloc-L operation.	Need to run TARE function to zero molbox2 RPTs.	Run TARE. <a href="#">[TARE]</a>

**Table 30. Troubleshooting List (cont.)**

<b>Symptom</b>	<b>Probable Cause</b>	<b>Solution</b>
Poor flow measurement characterized by instability and sudden small jumps in flow rate.	The molbox2 pneumatic circuit is contaminated with liquids.	Purge and clean molbox2 and associated pneumatic systems. Contact your Fluke Calibration authorized service provider.
Grossly inaccurate flow measurements and little or no response to pressure or flow changes.	RPT(s) destroyed by overpressure.	View pressure readings with  . If readings are grossly inaccurate and do not respond to pressure changes, contact your Fluke Calibration authorized service provider. <a href="#">[P&amp;T] (Pressure and Temperature)</a> , <a href="#">Reference Pressure Transducer (RPT)</a> , <a href="#">Overpressure</a> , <a href="#">Calibration Of Reference Pressure Transducers (RPTS)</a> .
Apparent inaccurate pressure measurement.	Incorrect pressure units.	Set desired pressure units. Consider reference temperature if unit is in Wa. <a href="#">&lt;8PRESU&gt;</a>
Apparent inaccurate pressure or flow measurement.	Reference pressure transducer (RPT) calibration coefficients have been altered or lost and pressure measurements are incorrect.	Check and correct calibration coefficients if needed. <a href="#">Calibration Of Reference Pressure Transducers (RPTS)</a>
MFC connected to molbox2 does not appear to respond.	MFC control option is not implemented on this molbox2.	Check whether molbox2 MFC control option was ordered and installed.
MFC connected to molbox2 does not appear to respond.	The MFC control function is not active (OFF).	Activate MFC control function by selecting a channel other than zero. <a href="#">[MFC] (Optional)</a>
MFC connected to molbox2 does not appear to respond correctly.	molbox2 to MFC control cable is not connected or connected incorrectly.	Check MFC cable connection and MFC cable configuration. <a href="#">MFC Control Function Adjustment</a>
MFC value and/or molbox2 flow values appear incorrect.	MFC profile does not correspond to MFC in use.	Check MFC profile and create and/or select correct one. <a href="#">MFC Profiles</a> , <a href="#">&lt;5MFC&gt;</a>

**Table 30. Troubleshooting List (cont.)**

Symptom	Probable Cause	Solution
MFC seems to be adjusting to set the requested flow value as read by the molbox.	MFC regulation mode is ON.	Operation is normal. Turn MFC regulation mode OFF. <6REG>
MFC value and/or molbox2 flow values appear incorrect.	Incorrect or inadvertent use of K factor and/or gas selection.	Check K factor and gas selection and correct if necessary. [K], [GAS]
 is not going to MFC set point screen. Cannot get to MFC set point entry.	The MFC control option is not implemented on this molbox or the current DISPLAY mode does not support MFC set point entry.	Check whether molbox2 MFC control option was ordered and installed. If MFC control option is present, use  to set DISPLAY mode to RATE, UNIT or CLEAN. [DISPLAY]

## Appendix

### Conversion of Numerical Values

molbox2 does all internal calculations in SI units. Numerical values input or output in other units are converted to SI immediately after entry and back to other units just before output as needed.

The tables below provide the conversion coefficients used by molbox2 to convert numerical values expressed in SI units to corresponding values expressed in other units.

#### Pressure

**Table 31. Pressure Unit Conversions**

To Convert Pa To		Multiply By
Pa	Pascal	1.0
Mbar	Millibar	1.0 E-02
KPa	kilo Pascal	1.0 E-03
Bar	Bar	1.0 E-05
mmWa @ 4 °C	Millimeter of water	1.019716 E-01
mmHg @ 0 °C	Millimeter of mercury	7.50063 E-03
Psi	pound per square inch	1.450377 E-04
Psf	pound per square foot	1.007206 E-06
inWa @ 4 °C	inch of water	4.014649 E-03
inWa @ 20 °C	inch of water	4.021732 E-03

**Table 31. Pressure Unit Conversions (cont.)**

To Convert Pa To		Multiply By
inWa @ 60 °F	inch of water	4.018429 E-03
inHg @ 0 °C	inch of mercury	2.953 E-04
kcm <sup>2</sup>	Kilogram force per centimeter square	1.019716 E-05
User	User	User defined coefficient

## Temperature

**Table 32. Temperature Unit Conversion**

To Convert from °C To	Multiply By
°F	9/5 and add 32

## Flow

**Table 33. Conversions from kg/s to sccm at °0 C for Various Gases**

To Convert From kg/s TO sccm at 0 °C	Multiply By
Air (Air)	4.64109 E+07
Argon (Ar)	3.36398 E+07
Butane (C <sub>4</sub> H <sub>10</sub> )	2.22112 E+07
Carbon Dioxide (CO <sub>2</sub> )	3.03490 E+07
Carbon Monoxide (CO)	4.79862 E+07
Carbon Tetrafluoride (CF <sub>4</sub> )	1.52386 E+07
Ethane (C <sub>2</sub> H <sub>6</sub> )	4.42602 E+07
Ethylene (C <sub>2</sub> H <sub>4</sub> )	4.75813 E+07
Fluoroform (CHF <sub>3</sub> )	1.90128 E+07
Helium (He)	3.36210 E+08
Hexafluoroethane (C <sub>2</sub> F <sub>6</sub> )	9.60432 E+06
Hydrogen (H <sub>2</sub> )	6.67483 E+08
Methane (CH <sub>4</sub> )	8.36354 E+07
Nitrogen (N <sub>2</sub> )	4.79808 E+07
Nitrous Oxide (N <sub>2</sub> O)	3.03321 E+07

**Table 33. Conversions from kg/s to sccm at 0 °C for Various Gases (cont.)**

To Convert From kg/s TO sccm at 0 °C	Multiply By
Oxygen (O <sub>2</sub> )	4.19903 E+07
Propane (C <sub>3</sub> H <sub>8</sub> )	2.98516 E+07
Sulfur Hexafluoride (SF <sub>6</sub> )	9.06602 E+06
Xenon (Xe)	1.01710 E+07

**Table 34. Conversions from sccm at 0 °C to Other Volumetrically Based Flow Units**

To Convert From sccm AT 0 °C To Other Volumetrically Based units	Multiply By
Slm	1.0 E-03
Slh	6.0 E-02
Scfm	3.53147 E-05
Scfh	2.11888 E-03
Sm3m	1.0 E-06
Sm3h	6.0 E-05

**Table 35. Conversions from Volumetrically Based Flow Units at 0 °C to Corresponding Units at Another Temperature (uxxx)**

To Convert Volumetrically Based Units at 0 °C To Corresponding Units at Another Temperature, Θ, (UXXX)	Multiply By
sccm slm slh scfm scfh sm3m sm3h	$\frac{(T_N + \theta) \cdot Z_{(P_N, (T_N + \theta))}}{T_N \cdot Z_N}$

Where:  $\theta$  = Alternate reference flow temperature C.

T<sub>N</sub> = 273.15K

P<sub>N</sub> = 101325 Pa

$Z_{(P_N, (T_N + \theta))}; Z_N$  gas dependent compressibility factors

**Table 36. Conversions from kg/s to mole/s for Various Gases**

To Convert kg/sec to mole/s	Multiply By
Air (Air)	3.45316 E+01
Argon (Ar)	2.50325 E+01
Butane (C <sub>4</sub> H <sub>10</sub> )	1.72049 E+01
Carbon Dioxide (CO <sub>2</sub> )	2.27221 E+01
Carbon Monoxide (CO)	3.57015 E+01
Carbon Tetrafluoride (CF <sub>4</sub> )	1.13624 E+01
Ethane (C <sub>2</sub> H <sub>6</sub> )	3.32568 E+01
Ethylene (C <sub>2</sub> H <sub>4</sub> )	3.56455 E+01
Fluoroform (CHF <sub>3</sub> )	1.42837 E+01
Helium (He)	2.49838 E+02
Hexafluoroethane (C <sub>2</sub> F <sub>6</sub> )	7.24533 E+00
Hydrogen (H <sub>2</sub> )	4.96032 E+02
Methane (CH <sub>4</sub> )	6.23325 E+01
Nitrogen (N <sub>2</sub> )	3.56939 E+01
Nitrouss Oxide (N <sub>2</sub> O)	2.27206 E+01
Oxygen (O <sub>2</sub> )	3.12512 E+01
Propane (C <sub>3</sub> H <sub>8</sub> )	2.26778 E+01
Sulfur Hexafluoride (SF <sub>6</sub> )	6.84697 E+00
Xenon (Xe)	7.61615 E+00

**Table 37. Conversion from mole/s to pccm**

To Convert mole/sec To pccm	Multiply By
Any Gas	1.34483 E+06

Note

The p in pccm indicates perfect in which a gas compressibility factor of 1 is assumed for all gases. In early 1996, SEMI, a semiconductor industry group, adopted standard E12-96 which specified that this definition be used for volumetrically base mass flow units.

**Table 38. Conversion from sccm at 0 °C  
to Volume Flow Units at Another Pressure and Temperature**

To Convert from a Volumetric Mass Flow Unit to the Equivalent volume Flow Unit at Temperature $\theta$ and $P_{USER}$	Multiply By
sccm to ccm slm to lm slh to lhs cfm to cfh scfh to cfh sm3m to m3m sm3h to m3h	$\frac{(T_N + \theta) \cdot Z_{(P_N, (T_N + \theta))}}{T_N \cdot Z_N} \frac{P_N}{P}$

Where:

$T_N=273.15K$

$P=$ User pressure [kPa]

$\theta=$ usertemperature [C]

$P_N=101.325$  kPa

$Z_{(P_{user}, (T_N + \theta))}; Z_N$  = gas dependent compressibility factors

## Valve Drivers

The molbox2 drivers option provides eight open collector drivers to operate external valves, solenoids, and indicators. When you operate from the setup-driver screen, push  to allow the operating mode of the drivers to be set. The two modes of operation are Momentary and Toggle. A momentary driver will be activated while the corresponding driver number on the keyboard is being pushed. In toggle mode, the driver state will toggle each time the corresponding key is pushed.

Each output can sink, 500 mA at 12 V. However, the total output of all the activated drivers cannot exceed 1 Amp. Therefore, if multiple drivers are being activated, refer to [Table 39](#) as a guide.

**Table 39. Driver/Max Current Per Output**

# of Active Drivers	MAX Current per Output
1	500 mA
2	400 mA
3	275 mA
4	200 mA
5	160 mA
6	135 mA
7	120 mA
8	100 mA

Use [Table 40](#) and [Figure 16](#) as references when building a cable to utilize the drivers port.

**Table 40. External Drivers**

Pin	Description	
A	D1	Driver #1 (Open Collector)
C	D2	Driver #2 (Open Collector)
E	D3	Driver #3 (Open Collector)
G	D4	Driver #4 (Open Collector)
M	D5	Driver #5 (Open Collector)
J	D6	Driver #6 (Open Collector)
11. K	12. D7	13. Driver #7 (Open Collector)
L	D8	Driver #8 (Open Collector)
B		Drivers (+12 V)
D		Drivers (+12 V)
F		Drivers (+12 V)
H		Drivers (+12 V)

**Figure 16. Cable Driver Ports**

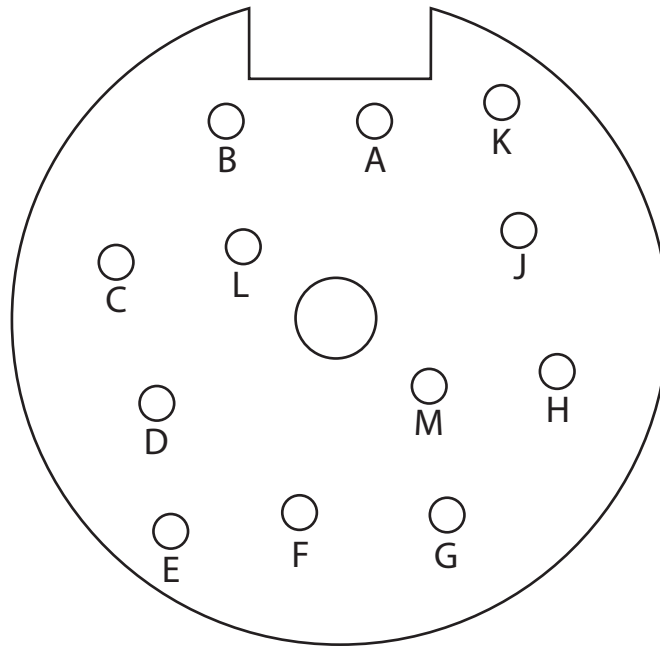

## MFC Control Function-MFC Connector

Use [Table 41](#) to correctly build the interfacing cable required to connect the molbox2 to an MFC.

**Table 41. Interface Cable Building Instructions**

molbox2 MFC Interface Connector (25 Pin DSUB) Pin No.	Signal Description
1	Case Ground
2	Supply Common
3	MFC Output (+)
4	+15 Volts
5	N/C
6	N/C
7	Set Point Sense (-)
8	N/C
9	N/C
10	N/C
11	Valve Test
12	Current MFC Output (+)
13	Current MFC Set (+)
14	MFC Setpoint (+)

**Table 41. Interface Cable Building Instructions (cont.)**

<b>molbox2 MFC Interface Connector (25 Pin DSUB) Pin No.</b>	<b>Signal Description</b>
15	MFC Setpoint (-)
16	MFC Output (-)
17	Valve Test Common
18	N/C
19	-15 Volts
20	Set Point Sense (+)
21	N/C
22	N/C
23	N/C
24	RS485 TXRX+
25	RS485 TXRX-

**Detailed Signal Descriptions**

- **+15 Volts:** The positive 15 V supply for the MFC.
- **-15 Volts:** The negative 15 V supply for the MFC.
- **Current MFC Output (+):** This signal is only used for current controlled MFCs. This is the 4 20 mA signal that represents the MFC output.
- **Current MFC Set (+):** This signal is only used for current controlled MFCs. This is the 4 mA to 20 mA signal that defines the necessary setpoint for the MFC. It is frequently referred to as the MFC control signal or the MFC setpoint.
- **MFC Output (+):** The positive 0 V to 5 V signal that represents the MFC output. It is commonly referred to as output or signal output.
- **MFC Output (-):** The ground reference for the MFC output signal. It is frequently referred to as *Signal Common*, or *Common*.
- **MFC Setpoint (+):** The necessary setpoint for the MFC. It is the signal that controls the amount of gas that the MFC will flow. It is generally a 0 V to 5 V signal where the 0 V signal causes the valve to close (zero flow) and 5 V signal cause the valve to open fully which results in full scale flow. This signal is commonly referred to as *MFC set point*, *MFC set voltage*, *MFC command*, or *MFC control*.
- **MFC Setpoint (-):** The ground reference for the MFC Setpoint signal. It is frequently referred to as *Signal Common*, or *Common*.
- **N/C:** This abbreviation stands for no connection. There are no signals on the lines marked N/C.

- **Set Point Sense (+):** This signal is used by the molbox2 to detect loss along the MFC cable. It represents the positive MFC set point as seen by the MFC. This line should be connected to the same point as the MFC Setpoint (+) line at the MFC side of the cable.
- **Set Point Sense (-):** The ground reference for the MFC Setpoint sense. It should be connected to the same point as the MFC setpoint (-) line.
- **Supply Common:** The ground line for the MFC power connection. It is frequently referred to as *Power Common*, *Supply Common*, or *Common*.
- **Valve Test:** This optional connection is used to read the valve test point signal coming from the MFC. If this signal is available at the MFC connector, it allows the user to read the internal voltage delivered to the MFC valve.
- **Valve Test Common:** The reference for the valve test signal. It may be connected to a common line or the -15 V line of the MFC, depending on the instructions of the MFC manufacturer for valve voltage measurement.

### Popular Configurations

The subsequent configuration can be used with most card edge style MFCs. Any differences tend to relate to the handling of the ground (common) lines (pins 2, B and C). Most cable problems can be resolved by either shorting pins B and C or by swapping the signals connected to pin 2 of the card edge connector with the signals connected to pin B of the card edge connector. The configuration below should work with the subsequent MFCs. See [Table 42](#).

- Millipore (Tylan) model FC260, 261, 262, FM 360, 361, 362
- Qualiflow AFC 260, 261, 202, 360, 361, 302
- Aera 2600, 2610, 2620, 3600, 3610, 3620
- PFD 501
- Porter 201
- Unit Instruments models UFC 1000,1020, 1100,1200, 1400, 1500

**Table 42. Common MFC Connector Pin Out**

<b>molbox2 MFC Interface Connector (25 pin DSUB) pin No.</b>	<b>Signal Description</b>	<b>MFC Card Edge Connector Pin Nos.</b>
1	Case Ground	1 (A1)
2	Supply Common	2 (A2)
3	MFC Output (+)	3 (A3)
4	+15 Volts	4 (A4)
7	Set Point Sense (-)	B (B2)
11	Valve Test	D (Optional) (B4)
14	MFC Setpoint (+)	A (B1)
15	MFC Setpoint (-)	B (B2)
16	MFC Output (-)	C (B3)
17	Valve Test Common	F (Optional) (B6)
19	-15 Volts	F (B6)
20	Set Point Sense (+)	A (B1)

Use the subsequent configuration.

- Brooks model 5850E, and 5851E

**Table 43. Brooks MFC Connector Pin Out**

<b>molbox2 MFC interface Connector (25 Pin DSUB) Pin No.</b>	<b>Signal Description</b>	<b>MFC Card Edge Connector Pin Nos.</b>	<b>MFC 15 Pin DSUB Connector Pin Nos.</b>
1	Case Ground	1 (A1)	14
2	Supply Common	C (B3)	9
3	MFC Output (+)	3 (A3)	2
4	+15 Volts	4 (A4)	5
7	Set Point Sense (-)	2 (A2)	10
11	Valve Test	D (Optional) (B4)	7 (Optional)
14	MFC Setpoint (+)	A (B1)	8
15	MFC Setpoint (-)	2 (A2)	10
16	MFC Output (-)	B (B2)	10
17	Valve Test Common	F (Optional) (B6)	10 (Optional)
19	-15 Volts	F (B6)	6
20	Set Point Sense (+)	A (B1)	8

## Glossary

<b>Absolute</b>	As in <i>absolute pressure</i> . Pressure expressed relative to vacuum.
<b>BPR</b>	Back Pressure Ratio. The ratio of the downstream pressure to the upstream pressure on a molbloc-S critical flow based molbloc element. The BPR is used to determine whether Critical Flow conditions exist so that molbloc-S flow measurements are valid.
<b>Critical flow</b>	Also known as <i>sonic flow</i> . Flow regime where the speed of gas is accelerated to a velocity equal to the speed of sound under current conditions and the flow rate can be predicted by measurement of the upstream pressure at the flow restriction (nozzle), the gas pressure and temperature conditions and the gas properties.
<b>Clean</b>	A DISPLAY function in which the second line of the display is blank (clean).
<b>Deviation</b>	A DISPLAY function in which the deviation from a target flow value is calculated and shown. The value of the difference between the target and the current flow reading.
<b>Differential</b>	As in <i>differential pressure</i> . Pressure expressed relative to a value other than vacuum or atmospheric pressure (see <b>absolute</b> and <b>gauge</b> ). Frequently refers to the pressure drop across the molbloc.
<b>Downstream</b>	Location of point A relative to point B in a flow system in which point A is at a different location in the direction of the flow. For example, the downstream molbloc pressure port is downstream relative to the upstream pressure port because it is at a different location from the upstream port in the direction of the flow.
<b>DUT</b>	Device Under Test. The device being tested or calibrated.
<b>FA (Flow Adder)</b>	Flow <i>adder</i> . A value that is added to the measured flow to offset the measured flow value.
<b>FM (Flow Multiplier)</b>	Flow <i>multiplier</i> . A value by which the measured flow is multiplied to change the slope of the measured flow.

<b>Freeze</b>	A DISPLAY function in which the current flow reading can be captured and shown by pushing  .
<b>Full Mod Calibration</b>	A molbloc calibration option which is valid over a range of operating pressure.
<b>FS</b>	Abbreviation of <i>full scale</i> . The full scale value is the maximum value or the span of a measurement range. Limits and specifications are often expressed as % FS.
<b>Gauge</b>	As in <i>gauge pressure</i> . Pressure expressed relative to atmospheric pressure.
<b>Head</b>	The differential pressure developed by differences in height between two points within a fluid medium.
<b>Hi/Lo</b>	A DISPLAY function in which the highest and lowest flow observed since hi/lo reset are recorded and displayed.
<b>K Factor</b>	A factor that represents the relationship between the process gas and a surrogate gas for a DUT.
<b>Operating Pressure</b>	The average pressure at which the molbloc is operated (average of upstream and downstream pressure) or, if the molbloc pressure is held constant by an upstream or downstream regulator, the value of the constant pressure.
<b>PA (Pressure Adder)</b>	Pressure <i>adder</i> , used in calibration adjustment to offset an RPT.
<b>Perfect Mass Flow Units</b>	Volumetrically based mass flow units of measure that assume ideal gas behavior for all gases (compressibility factor of 1).
<b>PM (Pressure Multiplier)</b>	Pressure <i>multiplier</i> , used in calibration to adjust span of an RPT.
<b>Pmax!</b>	The overpressure limit of an RPT. If the pressure measured exceeds (Pmax!) an overpressure condition occurs.
<b>Process Gas</b>	The gas for which a device under test (DUT) is to be characterized or calibrated. The gas that will actually flow in the DUT when it is used in a process.
<b>PRT</b>	Platinum Resistance Thermometer. The element used in molblochs to measure temperature.
<b>Psia</b>	Pressure unit <i>pounds per square inch absolute</i> . Pressure expressed relative to vacuum.
<b>Psig</b>	Pressure unit <i>pounds per square inch gauge</i> . Pressure expressed relative to atmospheric pressure.

<b>Rate</b>	A DISPLAY function in which the current rate of change of the flow in flow units/second is shown. A measure of stability of the flow. See also <b>Stability Limit</b> .
<b>Ready/Not Ready</b>	Indication of when flow is stable within the stability limit and below the flow Reynolds number limit. See also <b>Stability Limit</b> .
<b>Reynolds Number</b>	A ratio of the inertia forces to the viscous forces in a flowing fluid. This dimensionless number, which is dependent on fluid viscosity, density, velocity, and length of the flow field, is often used to predict a boundary point between laminar and turbulent flow regimes.
<b>RPT</b>	Reference Pressure Transducer. The pressure transducers used in molbox2 are referred to as RPTs.
<b>Single P Calibration</b>	A molbloc calibration option for gases other than N2 which is valid at a single specified operating pressure.
<b>Stability Limit</b>	A limit expressed in units of flow per second (for example, sccm/second). The stability limit is used as the <i>Ready/Not Ready</i> criterion <i>Ready</i> (<*>) if rate is less than stability limit, <i>Not Ready</i> (<↑> or <↓>) if rate is greater than stability limit. See also <b>Rate</b> .
<b>Surrogate Gas</b>	A gas whose behavior, from the standpoint of a device under test, is similar to the process gas for which the device is to be characterized and used. A surrogate gas is often used in calibration and testing when the process gas cannot be used for safety or cost reasons.
<b>Target</b>	The value from which deviations are measured in the DEVIATION DISPLAY function.
<b>Test Gas</b>	The gas flowing through the molbloc that is being used to run the test or calibration. The test gas, from the standpoint of the device under test, could be a surrogate gas or the process gas.
<b>Totalize</b>	A DISPLAY function in which the total mass or volume flowed over a period of time is accumulated.
<b>Upstream</b>	Location of point A relative to point B in a flow system in which point A is at a different location in the opposite direction of the flow. For example, the upstream molbloc pressure port is upstream relative to the downstream pressure port because it is at a different location from the downstream port in the opposite direction of the flow.

<b>User Level</b>	Level of security that can be set to prevent access to certain molbox2 functions.
<b>User Mass Flow Units</b>	Volumetrically based mass flow units of measure with a user set reference temperature.
<b>Venturi nozzle</b>	A flow orifice using a specific shape characterized by a convergent and divergent section, used to define flow measurements by measurement of flow conditions and gas properties. A critical flow Venturi nozzle is a Venturi nozzle used to define flows within the Critical flow regime.
<b>Volume Flow Pressure</b>	The absolute pressure of the flowing gas at the device under test for volume flow units of measure.
<b>Volume Flow Temperature</b>	The temperature of the flowing gas at the device under test for volume flow units of measure.
<b>Volume Flow Units</b>	Units of measure of volume (sometimes called <i>actual</i> ) flow.

Refer to [molbloc-S Ranges](#).

**Table 44. molbloc-S Pressure Dependent Flow Rates**

		molbloc-S Pressure Dependent Flow Rates: Min/Max Mass Flow Rate (slm @ 0C) (K <sub>f</sub> designator = sccm per kPa). <sup>[1][2][10]</sup>																				
		1E1-S		2E1-S		5E1-S		1E2-S		2E2-S		5E2-S		1E3-S		2E3-S		5E3-S		1E4-S		
		K <sub>f</sub> = 10		K <sub>f</sub> = 20		K <sub>f</sub> = 50		K <sub>f</sub> = 100		K <sub>f</sub> = 200		K <sub>f</sub> = 500		K <sub>f</sub> = 1000		K <sub>f</sub> = 2000		K <sub>f</sub> = 5000		K <sub>f</sub> = 10000		
Pressure Calibration Type		Min	Max	Min	Max	Min	Max	Min	Max	Min	Max	Min	Max	Min	Max	Min	Max	Min	Max	Min	Max	
<b>N2</b> Ratio = 1.000	Low Pressure (LP)	(with vacuum) <sup>[4]</sup>	0.2	2.0	0.4	4.0	1.0	10.0	2.0	20.0	4.0	40.0	10.0	100.0	20.0	200.0	40.0	400.0	100.0	1000.0	200.0	2000.0
		(no vacuum) <sup>[3][5]</sup>	2.0	2.0	3.5	4.0	7.7	10.0	15.0	20.0	28.0	40.0	67.0	100.0	129.0	200.0	248.0	400.0	596.0	1000.0	1173.0	2000.0
	Standard Pressure (SP)	(with vacuum) <sup>[6]</sup>	0.5	6.0	1.0	12.0	2.5	30.0	5.0	60.0	10.0	120.0	25.0	300.0	50.0	600.0	100.0	1200.0	250.0	3000.0	500.0	6000.0
		(no vacuum) <sup>[3][7]</sup>	2.0	6.0	3.5	12.0	7.7	30.0	15.0	60.0	28.0	120.0	67.0	300.0	129.0	600.0	248.0	1200.0	596.0	3000.0	1173.0	6000.0
High Pressure (HP) <sup>[8][9]</sup>		2.0	20.0	4.0	40.0	10.0	100.0	20.0	200.0	40.0	400.0	100.0	1000.0	200.0	2000.0	400.0	4000.0	1000.0	10000.0	2000.0	20000.0	
<b>Air</b> Ratio = 0.983	Low Pressure (LP)	(with vacuum) <sup>[4]</sup>	0.2	2.0	0.4	3.9	1.0	9.8	2.0	19.7	3.9	39.3	9.8	98.3	19.7	196.6	39.3	393.2	98.3	983.0	196.6	1966.0
		(no vacuum) <sup>[3][5]</sup>	2.0	2.0	3.4	3.9	7.6	9.8	15.2	19.7	27.4	39.3	67.1	98.3	126.7	196.6	243.9	393.2	585.2	983.0	1170.3	1966.0
	Standard Pressure (SP)	(with vacuum) <sup>[6]</sup>	0.5	5.9	1.0	11.8	2.5	29.5	4.9	59.0	9.8	118.0	24.6	294.9	49.2	589.8	98.3	1179.6	245.8	2949.0	491.5	5898.0
		(no vacuum) <sup>[3][7]</sup>	2.0	5.9	3.4	11.8	7.6	29.5	15.2	59.0	27.4	118.0	67.1	294.9	126.7	589.8	243.9	1179.6	585.2	2949.0	1170.3	5898.0
High Pressure (HP) <sup>[8][9]</sup>		2.0	19.7	3.9	39.3	9.8	98.3	19.7	196.6	39.3	393.2	98.3	983.0	196.6	1966.0	393.2	3932.0	983.0	9830.0	1966.0	19660.0	
<b>Argon</b> Ratio = 0.837	Low Pressure (LP)	(with vacuum) <sup>[4]</sup>	0.2	1.7	0.3	3.3	0.8	8.4	1.7	16.7	3.3	33.5	8.4	83.7	16.7	167.4	33.5	334.8	83.7	837.0	167.4	1674.0
		(no vacuum) <sup>[3][5]</sup>	1.7	1.7	3.0	3.3	6.5	8.4	12.9	16.7	23.3	33.5	57.1	83.7	107.8	167.4	207.6	334.8	498.2	837.0	996.2	1674.0
	Standard Pressure (SP)	(with vacuum) <sup>[6]</sup>	0.4	5.0	0.8	10.0	2.1	25.1	4.2	50.2	8.4	100.4	20.9	251.1	41.9	502.2	83.7	1004.4	209.3	2511.0	418.5	5022.0
		(no vacuum) <sup>[3][7]</sup>	1.7	5.0	3.0	10.0	6.5	25.1	12.9	50.2	23.3	100.4	57.1	251.1	107.8	502.2	207.6	1004.4	498.2	2511.0	996.2	5022.0
High Pressure (HP) <sup>[8][9]</sup>		1.7	16.7	3.3	33.5	8.4	83.7	16.7	167.4	33.5	334.8	83.7	837.0	167.4	1674.0	334.8	3348.0	837.0	8370.0	1674.0	16740.0	
<b>Helium</b> Ratio = 2.647	Low Pressure (LP)	(with vacuum) <sup>[4]</sup>	0.5	5.3	1.1	10.6	2.6	26.5	5.3	52.9	10.6	105.9	26.5	264.7	52.9	529.4	105.9	1058.8	264.7	2647.0	529.4	5294.0
		(no vacuum) <sup>[3][5]</sup>	NA <sup>[11]</sup>	NA <sup>[11]</sup>	NA <sup>[11]</sup>	NA <sup>[11]</sup>	25.7	26.5	51.4	52.9	91.5	105.9	199.4	264.7	398.7	529.4	695.1	1058.8	1737.8	2647.0	3281.0	5294.0
	Standard Pressure (SP)	(with vacuum) <sup>[6]</sup>	1.3	15.9	2.6	31.8	6.6	79.4	13.2	158.8	26.5	317.6	66.2	794.1	132.4	1588.2	264.7	3176.4	661.8	7941.0	1323.5	15882.0
		(no vacuum) <sup>[3][7]</sup>	NA <sup>[11]</sup>	NA <sup>[11]</sup>	NA <sup>[11]</sup>	NA <sup>[11]</sup>	25.7	79.4	51.4	158.8	91.5	317.6	199.4	794.1	398.7	1588.2	695.1	3176.4	1737.8	7941.0	3281.0	15882.0
High Pressure (HP) <sup>[8][9]</sup>		5.3	52.9	10.6	105.9	26.5	264.7	52.9	529.4	105.9	1058.8	264.7	2647.0	529.4	5294.0	1058.8	10588.0	2647.0	26470.0	5294.0	52940.0	
<b>CO2</b> Ratio = 0.795	Low Pressure (LP)	(with vacuum) <sup>[4]</sup>	0.2	1.6	0.3	3.2	0.8	8.0	1.6	15.9	3.2	31.8	8.0	79.5	15.9	159.0	31.8	318.0	79.5	795.0	159.0	1590.0
		(no vacuum) <sup>[3][5]</sup>	1.4	1.6	2.5	3.2	6.2	8.0	11.1	15.9	22.1	31.8	51.2	79.5	102.4	159.0	189.3	318.0	473.2	795.0	914.1	1590.0
	Standard Pressure (SP)	(with vacuum) <sup>[6]</sup>	0.4	4.8	0.8	9.5	2.0	23.9	4.0	47.7	8.0	95.4	19.9	238.5	39.8	477.0	79.5	954.0	198.8	2385.0	397.5	4770.0
		(no vacuum) <sup>[3][7]</sup>	1.4	4.8	2.5	9.5	6.2	23.9	11.1	47.7	22.1	95.4	51.2	238.5	102.4	477.0	189.3	954.0	473.2	2385.0	914.1	4770.0
High Pressure (HP) <sup>[8][9]</sup>		1.6	15.9	3.2	31.8	8.0	79.5	15.9	159.0	31.8	318.0	79.5	795.0	159.0	1590.0	318.0	3180.0	795.0	7950.0	1590.0	15900.0	

[1] Flow values in table are valid only when critical flow is established. Assumes proper pressurized gas supply and/or vacuum is used when needed to achieve the critical flow and that those sources can maintain the given flow rate.  
 [2] When volumetrically based flow units with reference temperatures other than 0 °C are used, flow values will generally be higher: the flow values for a given molbloc upstream pressure are approximately 7.7% higher when expressed in slm @ 21.1 °C (same as 70 °F). Flow values at a given pressure may vary by up to ±2 % due to flow path machining tolerances.  
 [3] Upstream pressure applied to achieve minimal critical flow rate with atmospheric pressure (approximately 100 kPaa) downstream of molbloc-S (no vacuum applied to the outlet).  
 [4] Low Pressure calibration (LP) (with vacuum) upstream minimum pressure=20 kPaa (3 PSia) and maximum pressure = 200 kPaa (30 PSia).  
 [5] Low Pressure calibration (LP) (no vacuum) upstream minimum pressure = atmospheric pressure on the outlet and maximum pressure = 200 kPaa (30 PSia).  
 [6] Standard Pressure (SP) (with vacuum) upstream minimum pressure = 50 kPaa (7 PSia) and maximum pressure = 600 kPaa (87 PSia).  
 [7] Standard Pressure (SP) (no vacuum) upstream minimum pressure = atmospheric pressure on the outlet and maximum pressure = 600k Paa (87 PSia).  
 [8] High Pressure (HP) upstream minimum pressure = 200 kPaa (30 PSia) and maximum pressure = 2 MPaa (290 PSia).  
 [9] Requires molbox2S A2M range to reach maximum flow. molbox2S A1.4 M will have reduced maximum flow.  
 [10] DUTs or other restrictions downstream of the molbloc-S can also limit usable flow range.  
 [11] Requires vacuum to achieve critical flow.

